

Sample Test 3

Name _____

In the real test you will have 10 questions and the following rules:

You have 50 minutes to complete the test below. The usage of books or notes, or communication with other students is not allowed. Ask me if you have questions.

This is a multiple choice test. You do not have to justify your answer. If, however, you are not sure that your selection is correct, put a star () in front of the question number, and include your calculations on an attached sheet. I will look at an attached calculation only if I see a star in front of the question number.*

-If you mark an incorrect answer but your calculations contain only minor mistakes, you will get up to 75% credit for the problem.

-Beware: if you instruct me to look at a severely incorrect calculation, you will lose at least 50% of the credit, even if by chance you mark the correct answer. (No credit is given for an incorrect answer and totally incorrect calculations.)

You get full credit if you mark the correct answer, and mark no star, or if you mark the correct answer, express doubt by marking a star, but I find your calculations perfectly correct.

Match the correct function to a given graph.

1)

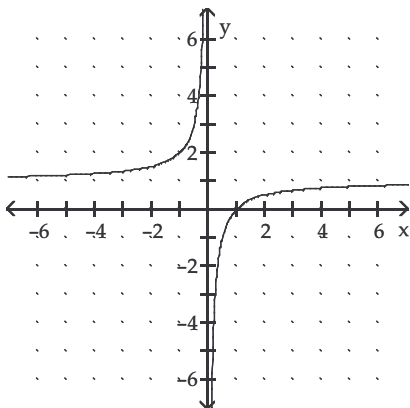

A) $f(x) = 1 - \frac{1}{x}$

B) $f(x) = \frac{1}{x} - 1$

C) $f(x) = 1 + \frac{1}{x}$

D) $f(x) = 1 - x$

Tell whether the graph of the function opens upward or downward and whether the graph is wider, narrower, or the same as $f(x) = x^2$.

2) $f(x) = -9x^2$

A) Downward, wider

B) Upward, narrower

C) Downward, narrower

D) Upward, wider

Solve the problem.

3) The price p and the quantity x sold of a certain product obey the demand equation: $p = -\frac{1}{8}x + 300$, $0 \leq x \leq 800$.

What is the revenue to the nearest dollar when 700 units are sold?

A) \$271,250

B) \$10,000

C) \$290,000

D) \$148,750

Find the equation of the axis of symmetry of the parabola.

4) $f(x) = (x + 2)^2 + 8$

A) $y = -2$

B) $x = 0$

C) $x = -2$

D) $x = 2$

Solve the problem.

- 5) The owner of a video store has determined that the profits P of the store are approximately given by $P = -x^2 + 60x + 60$, where x is the number of videos rented daily. Find the maximum profit to the nearest dollar.
- A) \$1800 B) \$1860 C) \$960 D) \$900

Find the x-intercepts and y-intercepts (if they exist).

- 6) $f(x) = x^2 + 8x$
- A) x-intercepts $(0, 0)$ and $(-8, 0)$; y-intercept $(0, 0)$ B) No x-intercept; y-intercept $(0, 0)$
C) x-intercepts $(0, -8)$ and $(-8, 0)$; y-intercept $(0, 0)$ D) x-intercepts $(0, 0)$ and $(8, 0)$; y-intercept $(0, 0)$

For the polynomial, list each real zero and its multiplicity. Determine whether the graph crosses or touches the x-axis at each x-intercept.

- 7) $f(x) = 2(x - 6)(x + 6)^2$
- A) -6 , multiplicity 1, touches x-axis; 6 , multiplicity 2, crosses x-axis
B) -6 , multiplicity 1, crosses x-axis; 6 , multiplicity 2, touches x-axis
C) 6 , multiplicity 1, touches x-axis; -6 , multiplicity 2, crosses x-axis
D) 6 , multiplicity 1, crosses x-axis; -6 , multiplicity 2, touches x-axis

Graph the function.

8) $f(x) = -2x(x + 1)^2$

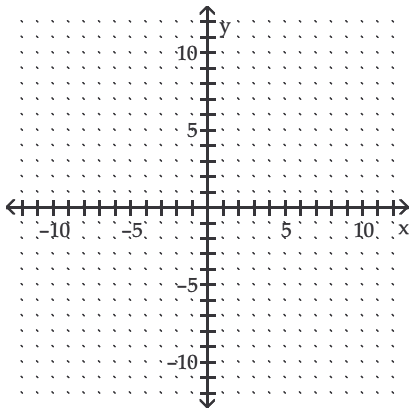

A)

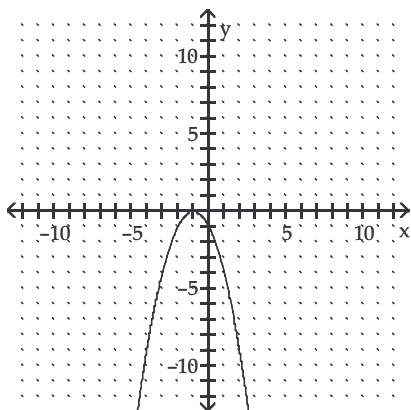

B)

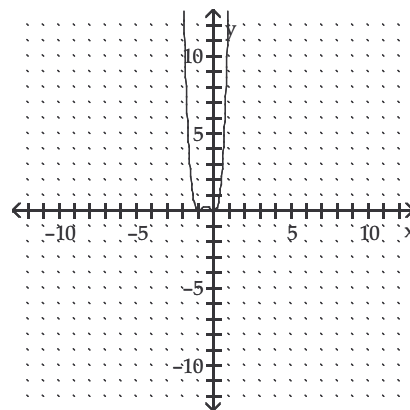

C)

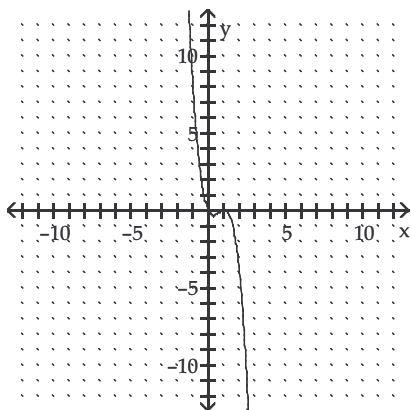

D)

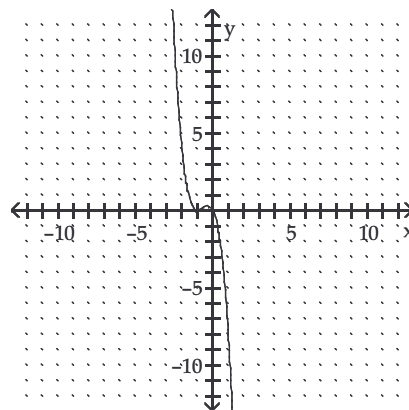

Give the possible values for the degree of the polynomial and the sign (+ or -) of the x^n term.

9)

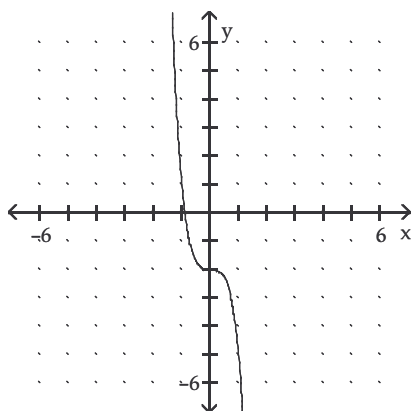
A) Degree is odd (3, 5, etc.);... x^n sign is negative.C) Degree is even (2, 4, 6 etc.);... x^n sign is positive.B) Can't identify degree; x^n sign is negative.D) Degree is even (2, 4, 6, etc.);... x^n sign is negative.

List all numbers that must be rejected as possible solutions.

$$10) \frac{12}{5x-7} + \frac{1}{x} = \frac{1}{7x+16}$$

A) $0, \frac{7}{5}, \frac{-16}{7}$

B) $\frac{7}{5}, \frac{-16}{7}$

C) $0, \frac{7}{5}, \frac{-16}{7}, 12$

D) $\frac{7}{5}, \frac{-16}{7}, -12$

Give the equation of the specified asymptote(s).

$$11) \text{ Horizontal asymptote: } h(x) = \frac{5x^2 - 9x - 6}{2x^2 - 2x + 3}$$

A) $y = \frac{5}{2}$

B) None

C) $y = \frac{9}{2}$

D) $y = 0$

$$12) \text{ Horizontal asymptote: } g(x) = \frac{x^2 + 4x - 8}{x - 8}$$

A) $y = -4$

B) $y = 8$

C) None

D) $y = 9$

13) Vertical asymptote(s): $h(x) = \frac{(x-6)(x+2)}{x^2-1}$

A) $x = -6, x = 2$

B) None

C) $x = 1, x = -1$

D) $x = 6, x = -2$

Solve the inequality.

14) $(b+4)(b+2)(b-6) < 0$

A) $(-\infty, -2)$

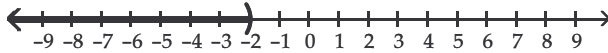

B) $(-4, -2) \cup (6, \infty)$

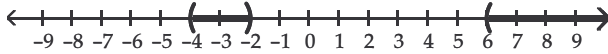

C) $(6, \infty)$

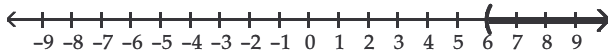

D) $(-\infty, -4) \cup (-2, 6)$

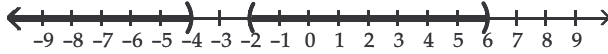

Solve the inequality. Write answer in interval notation.

15) $\frac{3x}{7-x} < x$

A) $(4, 7)$

B) $(-\infty, 4) \cup (7, \infty)$

C) $(7, \infty)$

D) $(0, 4) \cup (7, \infty)$

Use synthetic division.

16) $(3x^3 + 22x^2 + 22x - 12) \div (x + 6)$

A) $3x + 4$

B) $-3x^2 - 6x - 2$

C) $\frac{1}{2}x^2 + \frac{11}{3}x + \frac{11}{3}$

D) $3x^2 + 4x - 2$

Use the factor theorem to decide whether or not the second polynomial is a factor of the first.

17) $5x^2 + 5x + 30; x - 3$

A) Yes

B) No

Give the maximum number of zeros the polynomial function may have. Use Descartes's Rule of Signs to determine how many positive and how many negative zeros it may have.

18) $f(x) = 2x^5 - 3x^2 + x + 10$

A) 5, 2 or 0 positive zeros, 1 or 0 negative zeros

B) 5, 3 or 1 positive zeros, 3 or 1 negative zeros

C) 5, 2 or 0 positive zeros, 2 or 0 negative zeros

D) 5, 2 or 0 positive zeros, 1 negative zero

List the potential rational zeros of the polynomial function. Do not find the zeros.

19) $f(x) = 6x^4 + 4x^3 - 2x^2 + 2$

A) $\pm \frac{1}{6}, \pm \frac{1}{3}, \pm \frac{1}{2}, \pm \frac{2}{3}, \pm 1, \pm 2, \pm 3$

B) $\pm \frac{1}{6}, \pm \frac{1}{3}, \pm \frac{1}{2}, \pm 1, \pm 2$

C) $\pm \frac{1}{2}, \pm \frac{3}{2}, \pm 1, \pm 2, \pm 3, \pm 6$

D) $\pm \frac{1}{6}, \pm \frac{1}{3}, \pm \frac{1}{2}, \pm \frac{2}{3}, \pm 1, \pm 2$

Answer Key

Testname: STEST3.TST

- 1) A
- 2) C
- 3) D
- 4) C
- 5) C
- 6) A
- 7) D
- 8) D
- 9) A
- 10) A
- 11) A
- 12) C
- 13) C
- 14) D
- 15) D
- 16) D
- 17) B
- 18) D
- 19) D