

16

M16C/26 Group
Hardware Manual

RENESAS 16-BIT CMOS SINGLE-CHIP MICROCOMPUTER
M16C FAMILY / M16C/20 SERIES

Before using this material, please visit the our website to confirm that this is the most current document available.

Keep safety first in your circuit designs!

- Renesas Technology Corporation puts the maximum effort into making semiconductor products better and more reliable, but there is always the possibility that trouble may occur with them. Trouble with semiconductors may lead to personal injury, fire or property damage. Remember to give due consideration to safety when making your circuit designs, with appropriate measures such as (i) placement of substitutive, auxiliary circuits, (ii) use of non-flammable material or (iii) prevention against any malfunction or mishap.

Notes regarding these materials

- These materials are intended as a reference to assist our customers in the selection of the Renesas Technology Corporation product best suited to the customer's application; they do not convey any license under any intellectual property rights, or any other rights, belonging to Renesas Technology Corporation or a third party.
- Renesas Technology Corporation assumes no responsibility for any damage, or infringement of any third-party's rights, originating in the use of any product data, diagrams, charts, programs, algorithms, or circuit application examples contained in these materials.
- All information contained in these materials, including product data, diagrams, charts, programs and algorithms represents information on products at the time of publication of these materials, and are subject to change by Renesas Technology Corporation without notice due to product improvements or other reasons. It is therefore recommended that customers contact Renesas Technology Corporation or an authorized Renesas Technology Corporation product distributor for the latest product information before purchasing a product listed herein.

The information described here may contain technical inaccuracies or typographical errors. Renesas Technology Corporation assumes no responsibility for any damage, liability, or other loss rising from these inaccuracies or errors.

Please also pay attention to information published by Renesas Technology Corporation by various means, including the Renesas Technology Corporation Semiconductor home page (<http://www.renesas.com>).

- When using any or all of the information contained in these materials, including product data, diagrams, charts, programs, and algorithms, please be sure to evaluate all information as a total system before making a final decision on the applicability of the information and products. Renesas Technology Corporation assumes no responsibility for any damage, liability or other loss resulting from the information contained herein.
- Renesas Technology Corporation semiconductors are not designed or manufactured for use in a device or system that is used under circumstances in which human life is potentially at stake. Please contact Renesas Technology Corporation or an authorized Renesas Technology Corporation product distributor when considering the use of a product contained herein for any specific purposes, such as apparatus or systems for transportation, vehicular, medical, aerospace, nuclear, or undersea repeater use.
- The prior written approval of Renesas Technology Corporation is necessary to reprint or reproduce in whole or in part these materials.
- If these products or technologies are subject to the Japanese export control restrictions, they must be exported under a license from the Japanese government and cannot be imported into a country other than the approved destination.
Any diversion or reexport contrary to the export control laws and regulations of Japan and/or the country of destination is prohibited.
- Please contact Renesas Technology Corporation for further details on these materials or the products contained therein.

How to Use This Manual

This hardware manual provides detailed information on features in the M16C/26 Group microcomputer.

Users are expected to have basic knowledge of electric circuits, logical circuits and micro-computer.

Each register diagram contains bit functions with the following symbols and descriptions.

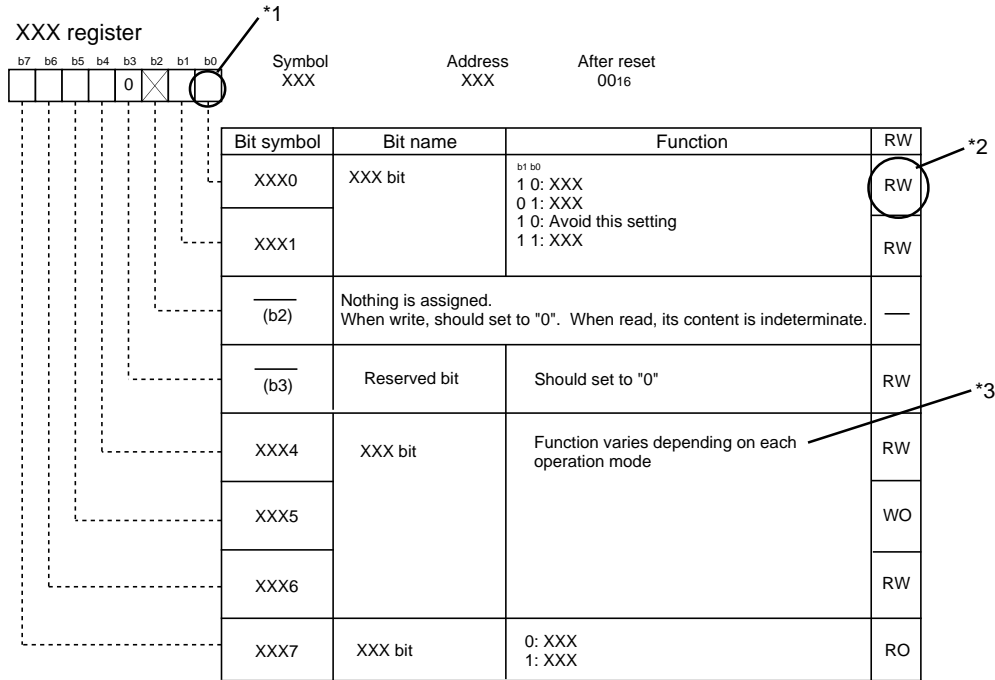

*1

Blank: Set to "0" or "1" according to your intended use

0: Set to "0"

1: Set to "1"

X: Nothing is assigned

*2

RW: Read and write

RO: Read only

WO: Write only

—: Nothing is assigned

*3

Terms to use here are explained as follows.

- Nothing is assigned

Nothing is assigned to the bit concerned. When write, set to "0" for new function in future plan.

- Reserved bit

Reserved bit. Set the specified value.

- Avoid this setting

The operation at having selected is not guaranteed.

- Function varies depending on each operation mode

Bit function varies depending on peripheral function mode.

Refer to register diagrams in each mode.

M16C Family Documents

Document	Contents
Short Sheet	Hardware overview
Data Sheet	Hardware overview and electrical characteristics
Hardware Manual	Hardware specifications (pin assignments, memory maps, specifications of peripheral functions, electrical characteristics, timing charts)
Software Manual	Detailed description about instructions and microcomputer performance by each instruction
Application Note	<ul style="list-style-type: none">• Application examples of peripheral functions• Sample programs• Introductory description about basic functions in M16C family• Programming method with the assembly and C languages

Table of Contents

Description	1
Functional Block Operation	8
Memory	8
Central Processing Unit (CPU)	9
Reset	12
Special Function Registers	20
Processor Mode	25
Clock Generating Circuit	28
Oscillation Stop Detection Function	34
Power Control	41
Protection	43
Interrupts	44
Watchdog Timer	64
DMAC	66
Timers	76
Timer A	78
Timer B	88
Three-Phase Motor Control Timer Function	94
Serial I/O	108
UART _i (i = 0 to 2)	108
Clock Synchronous Serial I/O Mode	119
Clock Asynchronous Serial I/O (UART) Mode	128
Clock Asynchronous Serial I/O Mode (used for SIM interface)	137
UART2 Special Mode Register	141
UART2 Special Mode Register 2	145
UART2 Special Mode Register 3	147
UART2 Special Mode Register 4	148
Serial Interface Special Function	150
A-D Converter	153
Programmable I/O Ports	163
Electrical Characteristics	171
Flash Memory	184
CPU Rewrite Mode	186
Functions To Inhibit Rewriting Flash Memory Version	202
Appendix Standard Serial I/O Mode (Flash Memory Version)	204
Appendix Standard Serial I/O Mode 1 (Flash Memory Version)	207
Appendix Standard Serial I/O Mode 2 (Flash Memory Version)	220

Description

The M16C/26 group of single-chip microcomputers incorporates Renesas' 16-bit M16C/60 Series CPU core, fabricated in a high-performance silicon gate CMOS process and packaged in 48-pin plastic molded LQFPs. Noted for fast instruction processing, these microcomputers are designed to operate using a sophisticated, yet highly-efficient instruction set. Their design is optimized for general application to the home, office, audio, and industrial sectors.

The M16C/26 group comprises a range of products of varied configuration. Note that the term "Virtual EEPROM" is used in this manual to denote Flash ROM blocks capable of a very high number of erase/write cycles. Simulated byte or word erase/write (E/W) requires firmware (available from Renesas).

Features

- Memory Flash ROM 24K to 64K bytes (1K minimum erase/write cycles)
plus Flash ROM 2K bytes x 2 blocks as Virtual EEPROM
(10K minimum erase/write cycles, 100K typical erase/write cycles)
Erase/write voltage for flash is from $V_{cc} = 2.7$ to 5.5 V
RAM 1K to 2K bytes.
- Shortest Instruction Execution Time 50ns ($f(X_{IN})=20$ MHz, $V_{cc}=3.0$ V to 5.5 V)
100ns ($f(X_{IN})=10$ MHz, $V_{cc}=2.7$ V to 5.5 V)
- Supply Voltage $V_{cc} = 3.0$ V to 5.5 V ($f(X_{IN}) = 20$ MHz, no wait)
 $V_{cc} = 2.7$ V to 5.5 V ($f(X_{IN}) = 10$ MHz, no wait)
- Low Power Consumption 0.7 μ A (typ) I_{cc} , Stop mode, $V_{cc} = 3.0$ V,
1.8 μ A (typ) I_{cc} at 32kHz Wait mode, $V_{cc} = 3.0$ V
25 μ A (typ) I_{cc} at 32kHz mode with RAM access (Flash sleep)
16mA (typ) I_{cc} at 20 MHz, $V_{cc} = 5.0$ V
- Interrupts 20 internal and 7 external interrupt sources
4 software interrupt sources; 7 priority levels
- Serial I/O 2 U(S)ART/SIO (UART 0/1)
1 U(S)ART/SIO/I²C bus/IEBus (UART 2) (Note 1,2)
- DMAC 2 Channels
- A-D Converter 10 bits X 8 channels
- Watchdog Timer 1 15-bit timer (switchable to internal ring oscillator)
- Timers 8 16-bit timers
 - 5 Timer A (Event counter, Event timer, One-shot generator, Pulse width measurement generation, Quadrature counter)
 - 3 Timer B (Event counter, Period measurement, Pulse width measurement, Timer)
 - 3-phase PWM generators for motor control
- Key-on Wake Up 4 inputs
- Programmable I/O 38 lines
- Brown-out Monitor With interrupt, reset and RAM retention flag capability.
- Clock Generation Circuit 3 built-in clock generation circuits
 - 2 internal clock generators (supports ceramic or quartz oscillator); crystal failure detect
 - 1 internal ring oscillator

Note 1: I²C bus is a registered trademark of Koninklijke Philips Electronics N. V.

Note 2: IEBus is a registered trademark of NEC Electronics Corporation.

Specifications written in this manual are believed to be accurate, but are not guaranteed to be entirely free of error. Specifications in this manual may be changed for functional or performance improvements. Please make sure your manual is the latest edition.

Applications

Industrial/audio/office equipment, home appliances, and other portable equipment.

Pin Configuration

Figure 1.1 shows the pin configuration for the M16C/26 group. Table 1.2 lists the pin descriptions.

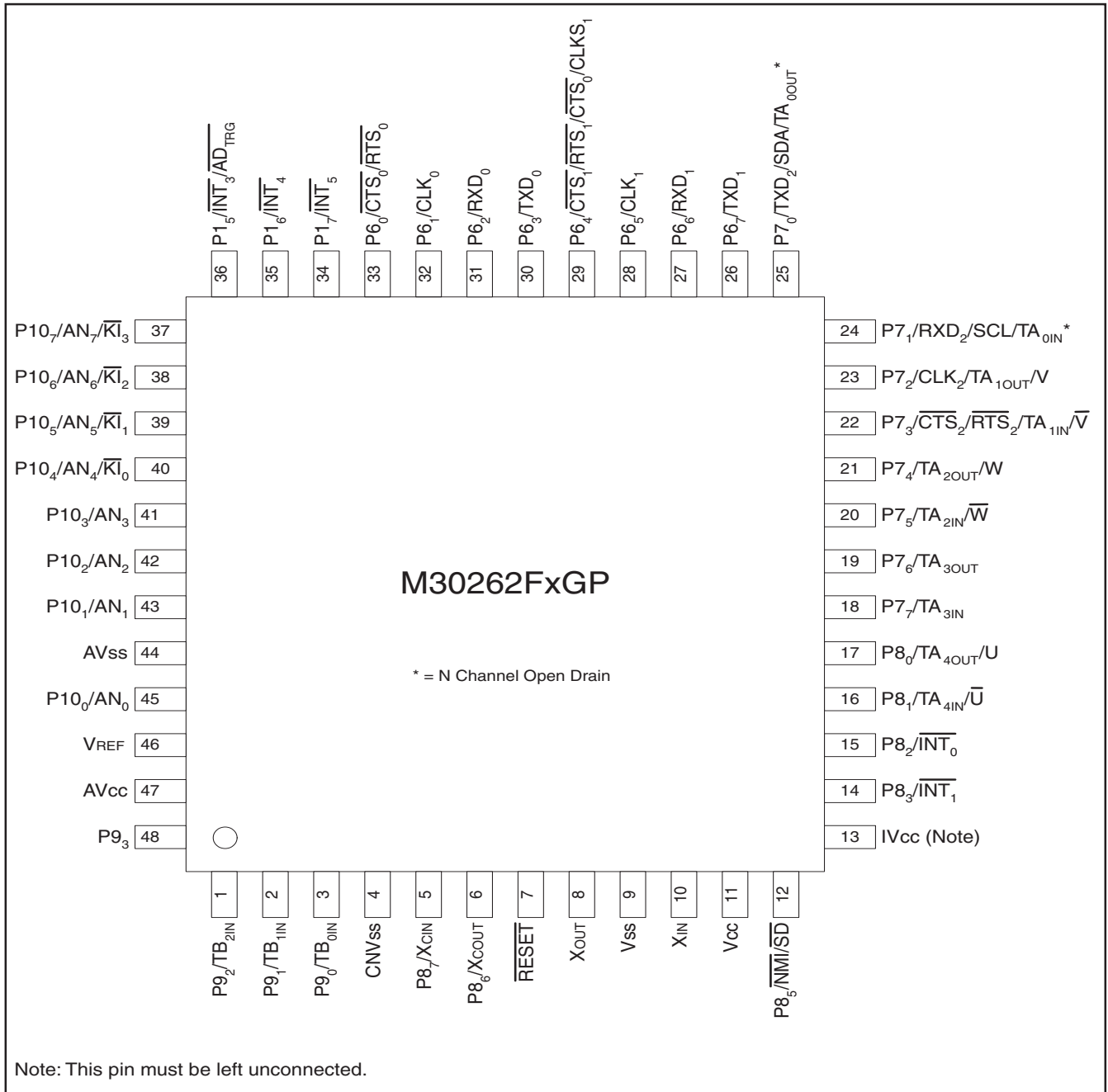

Figure 1.1. Pin configuration diagram (top view) of the M16C/26 group (48P6Q package)

Block Diagram

Figure 1.2 shows a block diagram of the M16C/26 group device.

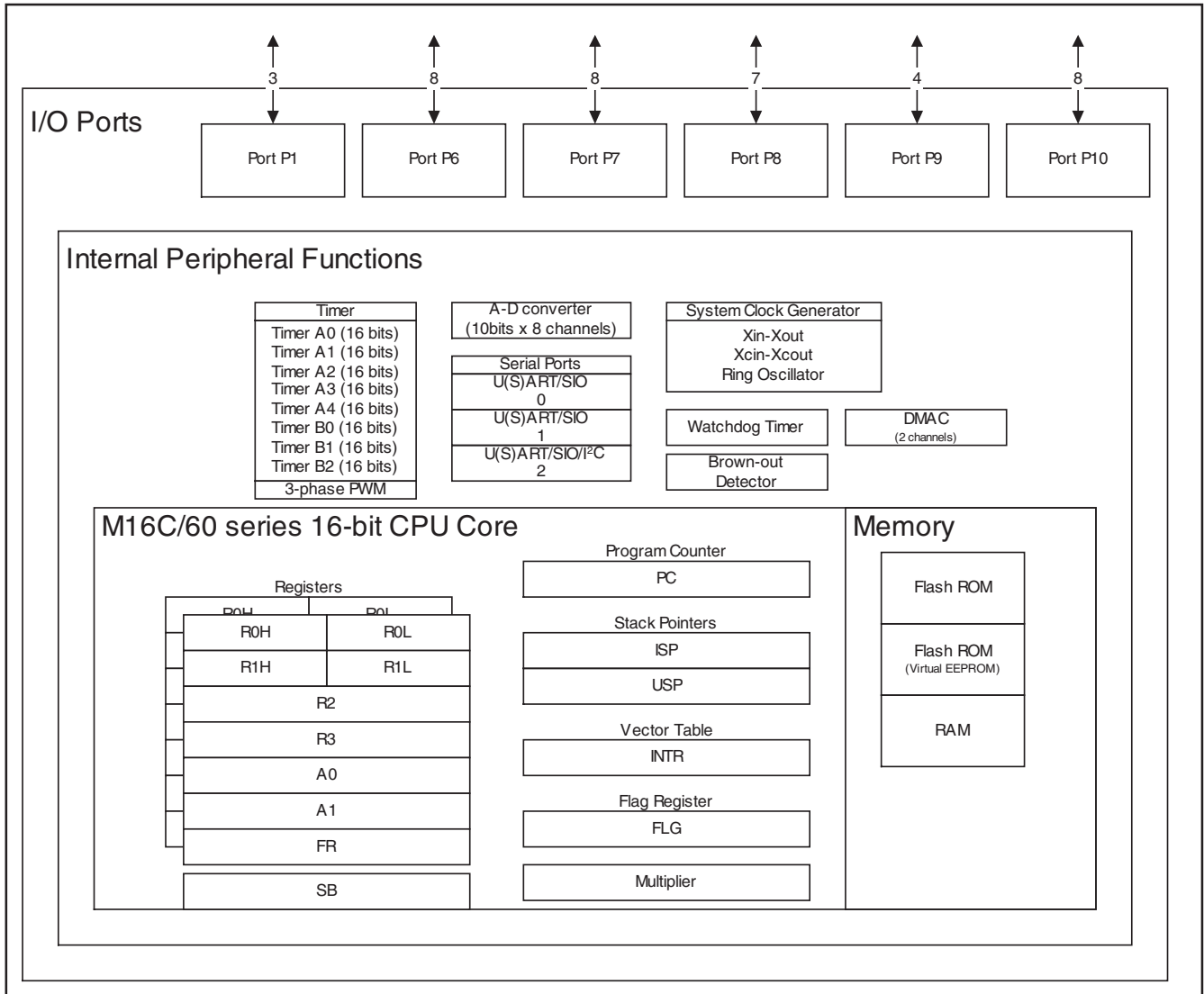

Figure 1.2. M16C/26 group block diagram

Performance Outline

Table 1.1 lists the parameters and functional description of the M16C/26 group.

Table 1.1. Performance outline

Parameters		Functional Description
Number of Basic Instructions		91
Shortest Instruction Execution Time		50ns (f(XIN)=20 MHz, Vcc=3.0V to 5.5V) 100ns (f(XIN)=10 MHz, Vcc=2.7V to 5.5V)
Memory	Flash ROM (Note 3)	(see the ROM expansion diagram) 1K (min) erase/write cycles, Erase/write Vcc = 2.7V to 5.5V
	Flash ROM as Virtual EEPROM (Note 3)	4 Kbytes (2 Kbyte x 2 Blocks) 10K minimum erase/write, 100K typical erase/write cycles Erase/write Vcc = 2.7V to 5.5V
	RAM	1K to 2K bytes
Multifunctional 16-bit Timers	TA0, TA1, TA2, TA3, TA4	Timer mode, Event counter, One-shot generator, PWM generation, Quadrature Counter
	TB0, TB1, TB2	Event counter, Period measurement, Pulse width measurement, Timer
	U/V/W	3-phase motor control PWM generator
Serial I/O		2 U(S)ART/SIO (UART0/1 type)
		1 U(S)ART/SIO/I ² C bus/IEBus (UART2) (Note 1,2)
A-D Converter		10 bits x 8 channels
DMAC		2 channels
Watchdog Timer		1 15-bit timer (switchable to internal ring oscillator)
Interrupts		20 internal, 7 external sources, 4 software, 7 priority levels
Clock Generation Circuit		3 built-in clock generating circuits • 2 internal clock generators (supports oscillator, crystal, resonator); crystal failure detect • 1 internal ring oscillator
Brown-out Monitor		With interrupt, reset and RAM retention flag capability
Programmable I/O		38 lines
Temperature Range		-20°C to 85°C / -40°C to 85°C (Note 3)
Supply Voltage		Vcc = 3.0V to 5.5 (f(fin) = 20MHz, no wait) Vcc = 2.7V to 5.5 (f(fin) = 10MHz, no wait)
Low Power Consumption		0.7 uA (typ) Icc, Stop mode, At Vcc = 3.0 V,
		1.8 uA (typ) Icc at 32 kHz, Wait mode, Vcc = 3.0 V
		25uA (typ) Icc at 32KHz mode with RAM access (Flash sleep)
		16mA (typ) Icc at 20 MHz, Vcc = 5.0 V
I/O Characteristics	I/O Withstand Voltage	5.0V
	Output Current	5mA
Device Configuration		CMOS high performance silicon gate
Packages		48-pin LQFP

Note 1: I²C bus is a registered trademark of Koninklijke Philips Electronics N. V.

Note 2: IEBus is a registered trademark of NEC Electronics Corporation.

Note 3: See Table 1.2b for erase/write cycle and temperature range information.

M16C Family Group

Figure 1.3 shows the type number, memory size and package for the M16C/26 group.

Tables 1.2a, 1.2b, and 1.2c list package, memory, and product marking information for configurations of the M16C/26 group.

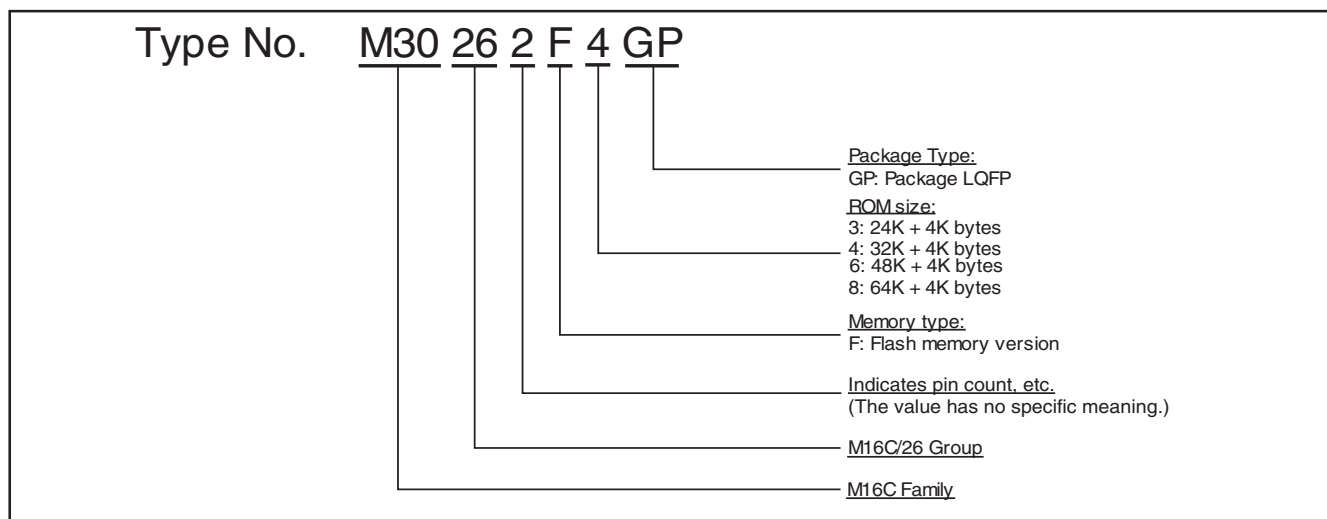

Figure 1.3. M3026x Product Family

Table 1.2a. Product list

Type No.	Package Type	RAM Capacity	Flash ROM	Virtual EEPROM Flash
M30262F3GP	48 LQFP (48P6Q)	1024 bytes	24 Kbyte (8K x 3)	4 Kbyte (2 Kbyte x 2)
M30262F4GP			32 Kbyte (16K x 1, 8K x 2)	
M30262F6GP		2048 bytes	48 Kbyte (16K x 2, 8K x 2)	
M30262F8GP			64 Kbyte (32K x 1, 16K x 1, 8K x 2)	

Table 1.2b. Microcomputer versus Flash Erase/Write (E/W) Operating Ranges

Product Code	Package	Internal ROM Block (0,1,2,3)		Internal ROM Block (A,B)		Microcomputer operating temperature
		E/W cycles	Temperature range	E/W cycles	Temperature range	
D3	non-Pb free	100	0C to 60C	100	0C to 60C	-40C to 85C
D5					-20C to 85C	
D7		1,000		10,000	-40C to 85C	-40C to 85C
D9					-20C to 85C	-20C to 85C
U3 ★	Pb free	100	0C to 60C	100	0C to 60C	-40C to 85C
U5 ★					-20C to 85C	
U7 ★		1,000		10,000	-40C to 85C	-40C to 85C
U9 ★					-20C to 85C	-20C to 85C

★: under planning

Table 1.2c. Product Marking (top view)

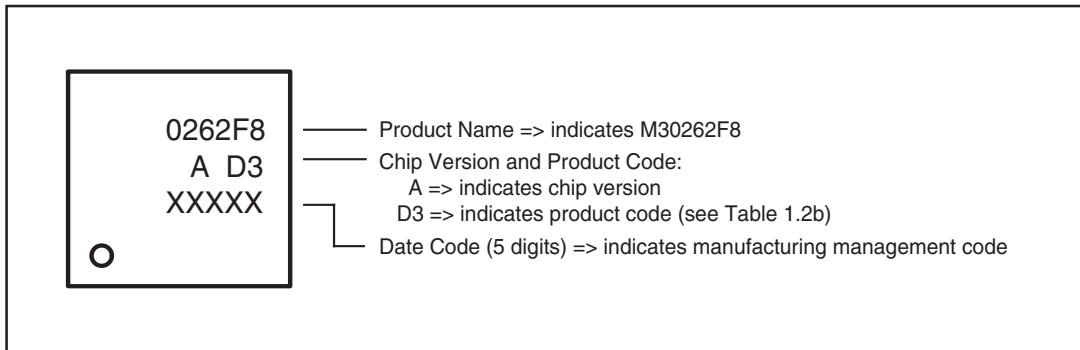

Pin Description

Pin name	Signal name	I/O type	Function
V _{CC} , V _{SS}	Power supply input		Supply 2.7V to 5.5V to the V _{CC} pin. Supply 0V to the V _{SS} pin.
CNV _{SS}	CNV _{SS}	Input	This pin is used to select, at reset, operation in either single-chip user or serial boot programming mode. If connected to V _{SS} , operation after reset will employ single-chip user mode. If connected to V _{CC} , reset will cause entry into boot mode.
RESET	Reset input	Input	A "L" on this input resets the microcomputer.
IV _{CC}	Power supply		The user must leave this pin unconnected.
X _{IN} X _{OUT}	Clock input Clock output	Input Output	These pins are provided for the main clock generating circuit. Connect a ceramic resonator or crystal between the X _{IN} and the X _{OUT} pins. To use an externally-derived clock, input it to the X _{IN} pin and leave the X _{OUT} pin open.
AV _{CC}	Analog power supply input		This pin is a power supply input for the A-D converter. Connect this pin to V _{CC} .
AV _{SS}	Analog power supply input		This pin is a power supply input for the A-D converter. Connect this pin to V _{SS} .
V _{REF}	Reference voltage input	Input	This pin is a reference voltage input for the A-D converter.
P1 ₅ to P1 ₇	I/O port P1	Input/output	This is a 3-bit I/O port. When used for input pin, the port can be set to have or not have a pull-up resistor by software. P1 ₅ to P1 ₇ also function as the input pins for external interrupts INT ₃ to INT ₅ as selected by software. Additionally, P1 ₅ can be configured to act as the A/D trigger source (AD _{TRG}).
P6 ₀ to P6 ₇	I/O port P6	Input/output	This is an 8-bit I/O port. When used for input pin, the port can be set to have or not have a pull-up resistor in units of four bits by software. Pins in this port also function as UART0 and UART1 I/O pins as selected by software.
P7 ₀ to P7 ₇	I/O port P7	Input/output	This is an 8-bit I/O port. When used for input pin, the port can be set to have or not have a pull-up resistor in units of four bits by software (P7 ₀ to P7 ₁ are N channel open-drain outputs). Pins in this port also function as timer A0-A3 I/O, UART2 I/O pins, or 3-phase PWM V/W outputs as selected by software.
P8 ₀ to P8 ₃ , P8 ₅ to P8 ₇	I/O port P8	Input/output	This is a 7-bit I/O port. When used for input pin, the port can be set to have or not have a pull-up resistor in units of four bits by software. Using software, they can be made to function as the I/O pins for timer A4, the input pins for external interrupts INT0, INT1, NMI, or 3-phase PWM U outputs and 3-phase PWM shutdown input. P8 ₆ to P8 ₇ can be set using software to function as the I/O pins for a sub clock generation circuit. In this case, connect a quartz oscillator between P8 ₆ (X _{COUT} pin) and P8 ₇ (X _{CIN} pin).
P9 ₀ to P9 ₃	I/O port P9	Input/output	This is a 4-bit I/O port. When used for input pin, the port can be set to have or not have a pull-up resistor in units of four bits by software. Pins in this port also function as Timer B0-B2 input pins as selected by software.
P10 ₀ to P10 ₇	I/O port P10	Input/output	This is an 8-bit I/O port. When used for input pin, the port can be set to have or not have a pull-up resistor in units of four bits by software. Pins in this port also function as A-D converter input pins as selected by software. Furthermore, P10 ₄ -P10 ₇ also function as input pins for the key input interrupt function pins as selected by software.

Table 1.3. Pin Descriptions

Functional Block Operation

The M16C/26 group accommodates certain units in a single chip. These units include ROM and RAM to store instructions and data and the central processing unit (CPU) to execute arithmetic/logic operations. Also included are peripheral units such as timers, serial I/O, A-D converter, and I/O ports.

Memory

Figure 1.4.1 is a memory map of the M16C/26 group. The linear address space of 1M bytes extends from address 00000₁₆ to FFFFF₁₆. From FFFFF₁₆ down is ROM. For example, in the M30262F4, there is 32K bytes of internal ROM from F8000₁₆ to FFFFF₁₆. The vector table for fixed interrupts such as the reset and NMI are mapped to FFFDC₁₆ to FFFFF₁₆. The starting address of the interrupt routine is stored here. The address of the vector table for timer interrupts, etc., can be set as desired using the internal register (INTB). See the section on interrupts for details.

From 00400₁₆ up is RAM. For example, in the M30262F4, 1K bytes of internal RAM is mapped to the space from 00400₁₆ to 07FF₁₆. In addition to storing data, the RAM also stores the stack used when calling subroutines and when interrupts are generated.

These devices also contain two blocks of Flash ROM as Virtual EEPROM memory to store data. These 2 blocks of 2K bytes are located from 0F000₁₆ to 0FFFF₁₆ on all versions.

The SFR area is mapped from 00000₁₆ to 003FF₁₆. This area accommodates the control registers for peripheral devices such as I/O ports, A-D converter, serial I/O, and timers, etc. Any part of the SFR area that is not occupied is reserved and cannot be used for other purposes.

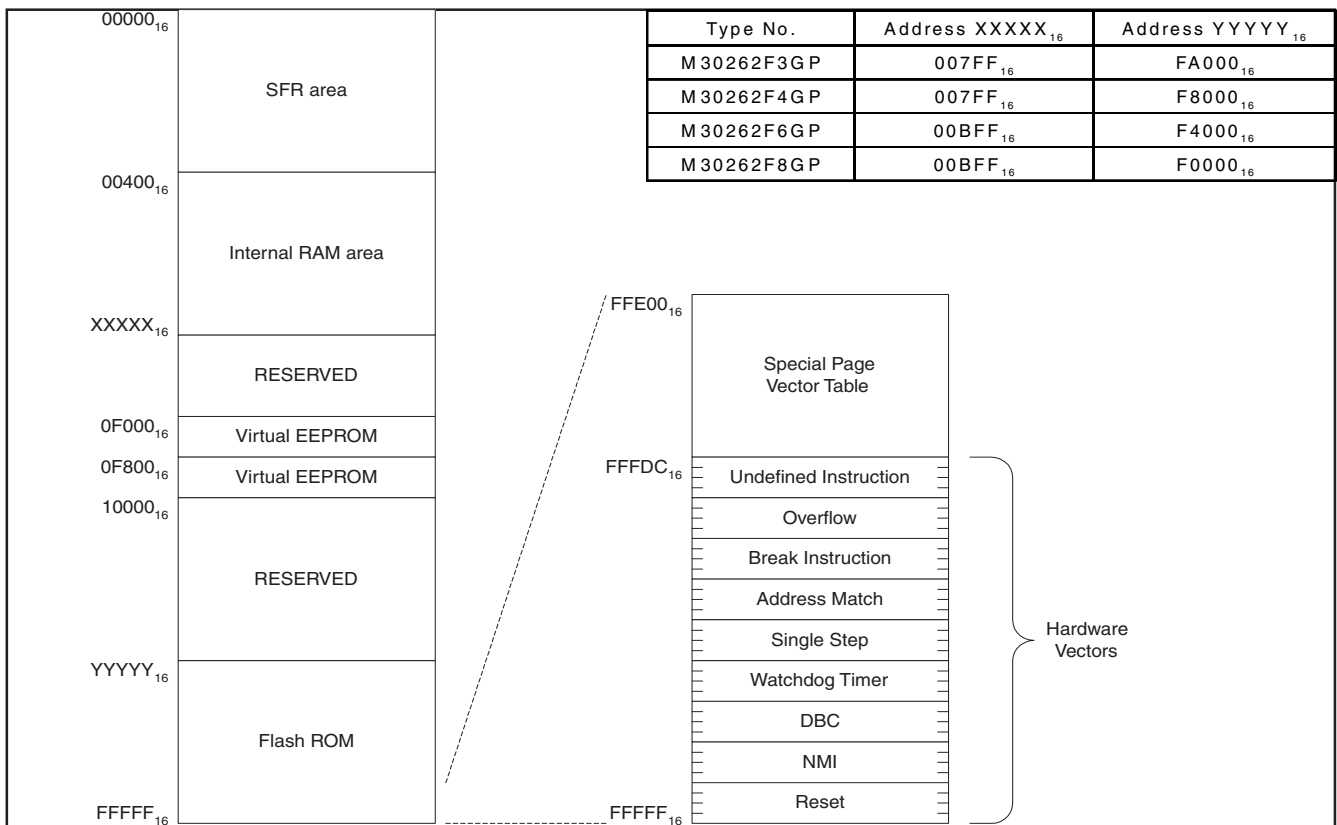

Figure 1.4.1. Memory map

Central Processing Unit (CPU)

The CPU has a total of 13 registers shown in Figure 1.4.2. Seven of these registers (R0, R1, R2, R3, A0, A1, and FB) come in two sets; therefore, these have two register banks.

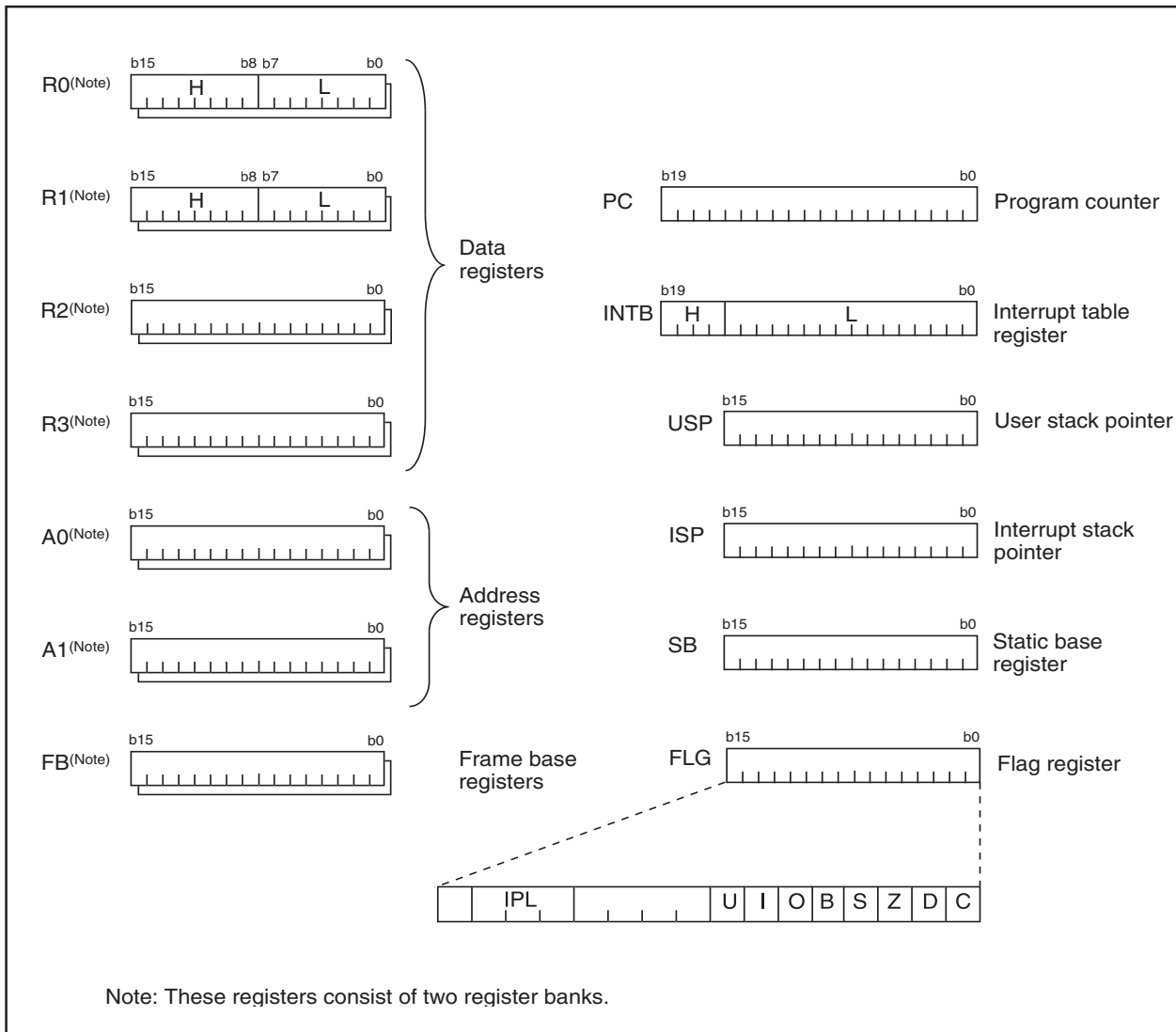

Figure 1.4.2. Central processing unit register

(1) Data registers (R0, R0H, R0L, R1, R1H, R1L, R2, and R3)

Data registers (R0, R1, R2, and R3) are configured with 16 bits, and are used primarily for transfer and arithmetic/logic operations.

Registers R0 and R1 can each be used as dual 8-bit data registers. As such, their high-order bytes are designated R0H/R1H, while their low-order bytes become R0L/R1L, respectively. In some instructions, registers R2 and R0, as well as R3 and R1, can be combined to serve as 32-bit data registers (R2R0/R3R1).

(2) Address registers (A0 and A1)

Address registers (A0 and A1) consist of 16 bits each. Individually, they can be used for three types of register-based addressing: register direct, address register indirect, and address register relative. They are also used for transfer and arithmetic/logic operations, as well as three special instruction addressing modes: address register relative with 20-bit displacement, 32-bit address register indirect, and 32-bit register direct. These last two modes combine A0 and A1 for use as a single 32-bit register (A1A0).

(3) Frame base register (FB)

Frame base register (FB) is configured with 16 bits, and is used for FB relative addressing.

(4) Program counter (PC)

Program counter (PC) is configured with 20 bits, indicating the address of an instruction to be executed.

(5) Interrupt table register (INTB)

Interrupt table register (INTB) is configured with 20 bits, indicating the start address of an interrupt vector table.

(6) Stack pointer (USP/ISP)

Stack pointer comes in two types: user stack pointer (USP) and interrupt stack pointer (ISP), each configured with 16 bits.

Your desired type of stack pointer (USP or ISP) can be selected by a stack pointer select flag (U flag). This flag is located at the position of bit 7 in the flag register (FLG).

(7) Static base register (SB)

Static base register (SB) is configured with 16 bits, and is used for SB relative addressing.

(8) Flag register (FLG)

Flag register (FLG) is configured with 11 bits, each bit is used as a flag. Figure 1.4.3 shows the flag register (FLG). The following explains the function of each flag:

- **Bit 0: Carry flag (C flag)**

This flag retains a carry, borrow, or shift-out bit that has occurred in the arithmetic/logic unit.

- **Bit 1: Debug flag (D flag)**

This flag enables a single-step interrupt.

When this flag is “1”, a single-step interrupt is generated after instruction execution. This flag is cleared to “0” when the interrupt is acknowledged.

- **Bit 2: Zero flag (Z flag)**

This flag is set to “1” when an arithmetic operation resulted in 0; otherwise, cleared to “0”.

- **Bit 3: Sign flag (S flag)**

This flag is set to “1” when an arithmetic operation resulted in a negative value; otherwise, cleared to “0”.

- **Bit 4: Register bank select flag (B flag)**

This flag chooses a register bank. Register bank 0 is selected when this flag is “0”; register bank 1 is selected when this flag is “1”.

- **Bit 5: Overflow flag (O flag)**

This flag is set to “1” when an arithmetic operation resulted in overflow.

- **Bit 6: Interrupt enable flag (I flag)**

This flag enables a maskable interrupt.

An interrupt is disabled when this flag is “0”, and is enabled when this flag is “1”. This flag is cleared to “0” when the interrupt is acknowledged.

- **Bit 7: Stack pointer select flag (U flag)**

Interrupt stack pointer (ISP) is selected when this flag is “0”; user stack pointer (USP) is selected when this flag is “1”.

This flag is cleared to “0” when a hardware interrupt is acknowledged or an INT instruction of software interrupt Nos. 0 to 31 is executed.

- **Bits 8 to 11: Reserved area**

- **Bits 12 to 14: Processor interrupt priority level (IPL)**

Processor interrupt priority level (IPL) is configured with three bits, for specification of up to eight processor interrupt priority levels from level 0 to level 7.

If a requested interrupt has priority greater than the processor interrupt priority level (IPL), the interrupt is enabled.

- **Bit 15: Reserved area**

The C, Z, S, and O flags are changed when instructions are executed. See the software manual for details.

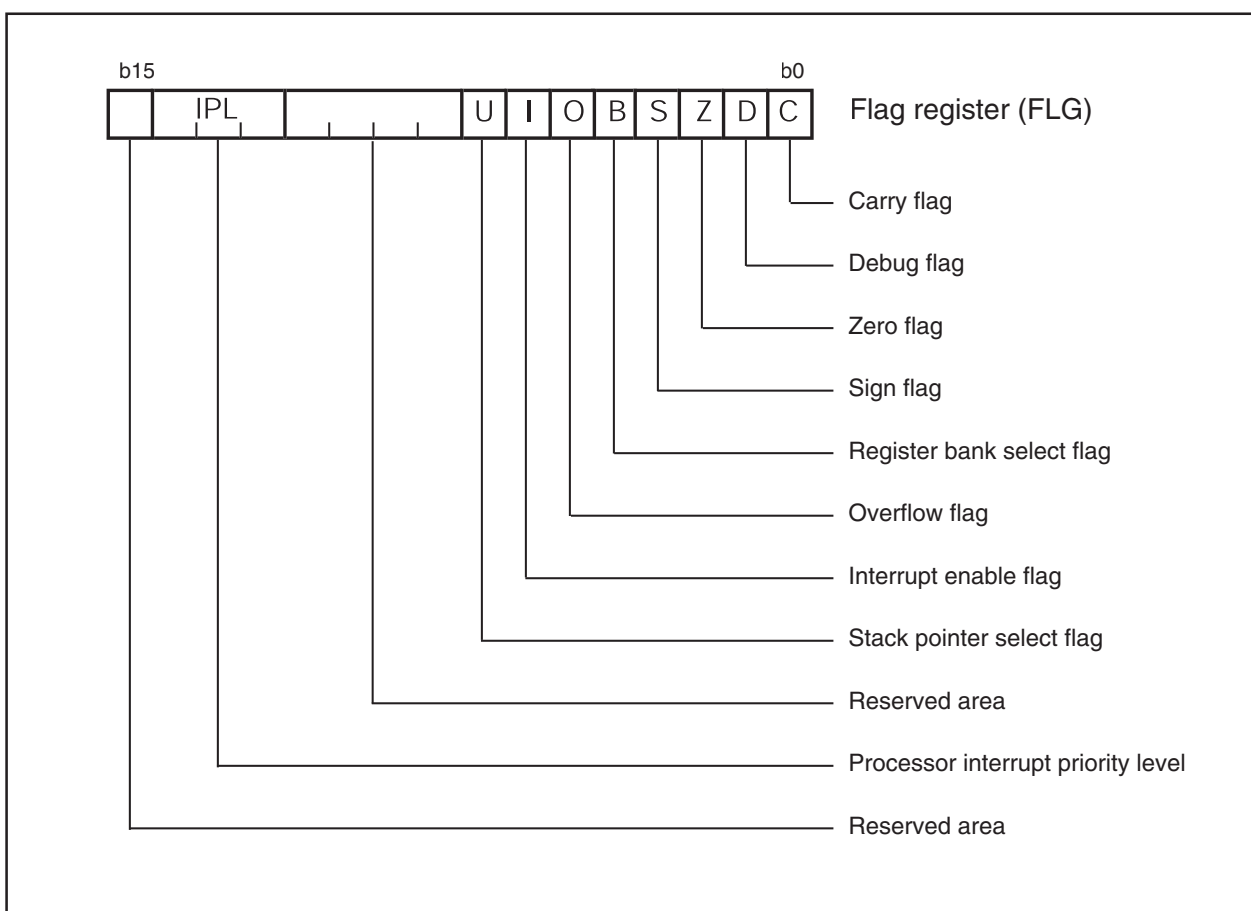

Figure 1.4.3. Flag register (FLG)

Reset

There are two types of reset: a hardware reset and a software reset (See “Software Reset” for details on software resets.)

Hardware reset

There are two kinds of hardware reset: hardware reset 1 and hardware reset 2.

Hardware reset 1

A reset is applied using the RESET pin. When a low-level signal (“L”) is applied to the RESET pin, while the power supply voltage is within the recommended operating voltage, the pins are initialized (see Table 1.5.1). When the input level of the RESET pin is released from low to high, the CPU and SFR are initialized. The program is executed starting from the address indicated by the reset vector. The internal RAM is not initialized. If the RESET pin is pulled low while writing to the internal RAM, the internal RAM becomes indeterminate.

Figure 1.5.1 shows an example of the reset circuit. Table 1.5.1 shows the status of the other pins while the RESET pin is “L”. Figure 1.5.2 shows the reset sequence. Figure 1.5.3 shows the status of the CPU registers. Refer to the SFR section on the status of SFR registers after reset.

1. When the power supply is stable (warm start)
 - (1) Apply a low-level signal to the RESET pin
 - (2) Supply at least 20 clock cycles to the XIN pin
 - (3) Apply a high-level signal to the RESET pin
2. Power on (cold start)
 - (1) Apply a low-level signal to the RESET pin
 - (2) Turn on or increase the power supply voltage until it meets the recommended operation voltage.
 - (3) Wait at least 2ms for the power supply to stabilize
 - (4) Supply at least 20 clock cycles to the XIN pin
 - (5) Apply a high-level signal to the RESET pin

Hardware reset 2

This reset is generated by the microcomputer's internal voltage detection circuit. The voltage detection circuit monitors the voltage supplied to the VCC pin. A reset is generated when the VCC input voltage drops to V_{DET3} or less while VCR2 register's VC26 bit is equal to “1” (V_{DET3} detection circuit enabled). When the input voltage increases so it is greater than V_{DET3} , the CPU, SFR, and pins are initialized, and the program is executed starting from the address indicated by the reset vector. After V_{DET3} is detected, it takes about 2ms before the program is executed. The status of the pins and registers after the reset is similar to that of hardware reset 1.

Take note, however, that the value of VC26 has no effect in stop mode. Therefore, a reset is not applied even if the VCC input voltage drops to V_{DET3} or lower.

Software reset

When the PM0 register's PM03 bit is set "1" (microcomputer reset), the CPU, SFR, and pins of the microcomputer are initialized similar to a hardware reset. After reset, the program is executed starting from the address indicated by the reset vector.

Figure 1.5.2 shows the reset sequence and Figure 1.5.3 shows the status of the CPU registers after reset.

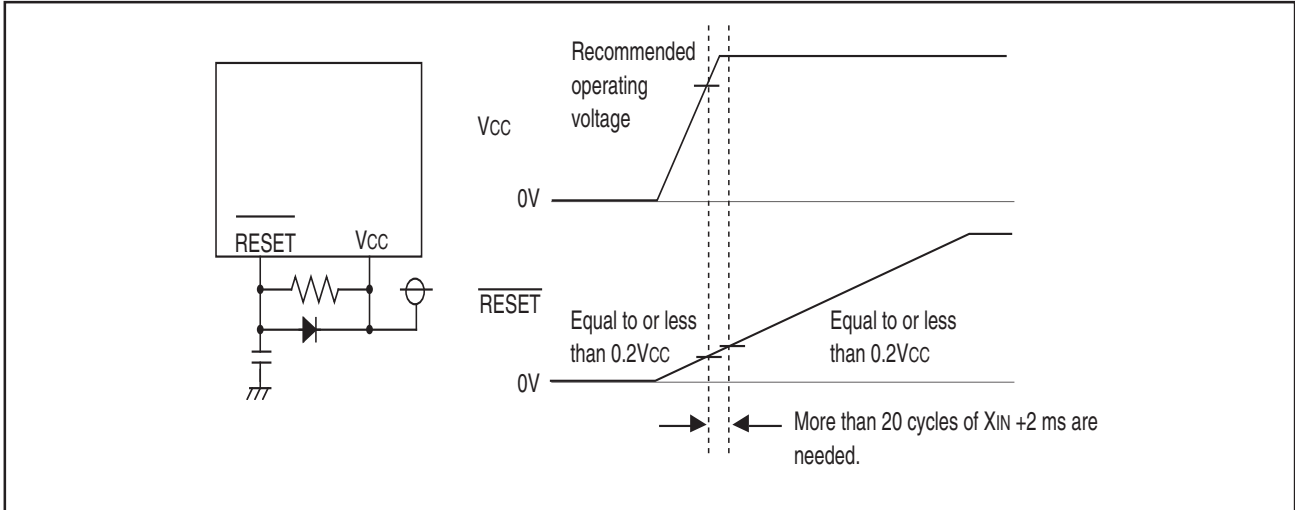

Figure 1.5.1. Example reset circuit

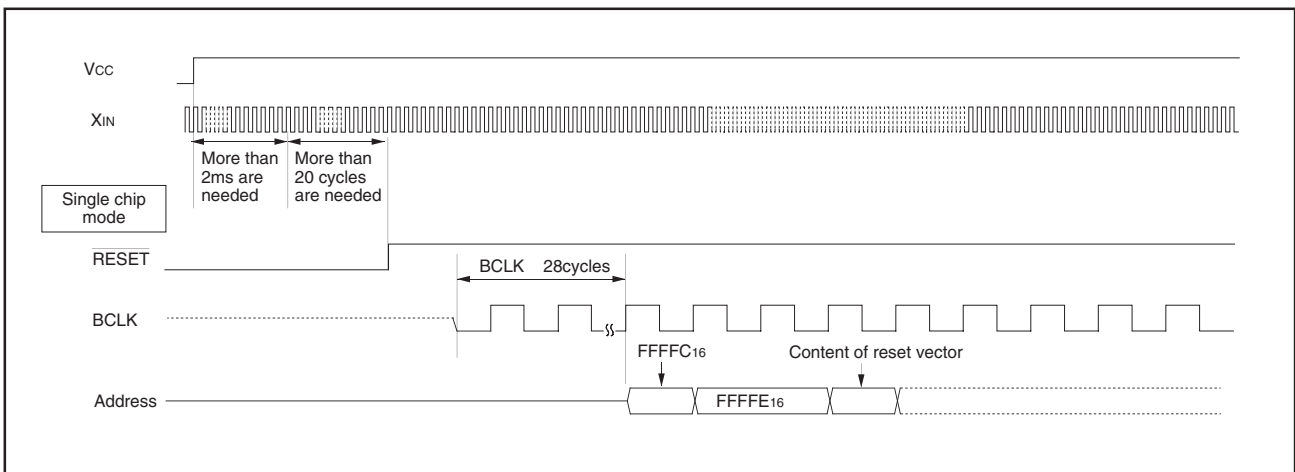

Figure 1.5.2. Reset sequence

Table 1.5.1. Pin status at RESET for User / Boot operating modes

Pin name	Status	
	User Mode (CNVss = Vss)	Boot Mode (CNVss = Vcc)
P15 to P17	Input port (high impedance)	Data input (high impedance)
P60 to P63	Input port (high impedance)	Data input (high impedance)
P64	Input port (high impedance)	BUSY output
P65	Input port (high impedance)	SCLK input
P66	Input port (high impedance)	RXD input
P67	Input port (high impedance)	TXD output
P7	Input port (high impedance)	Data input (high impedance)
P80 to P83, P85	Input port (high impedance)	Data input (high impedance)
P86	Input port (high impedance)	\overline{CE} input
P87	Input port (high impedance)	Data input (high impedance)
P90 to P93, P10	Input port (high impedance)	Data input (high impedance)

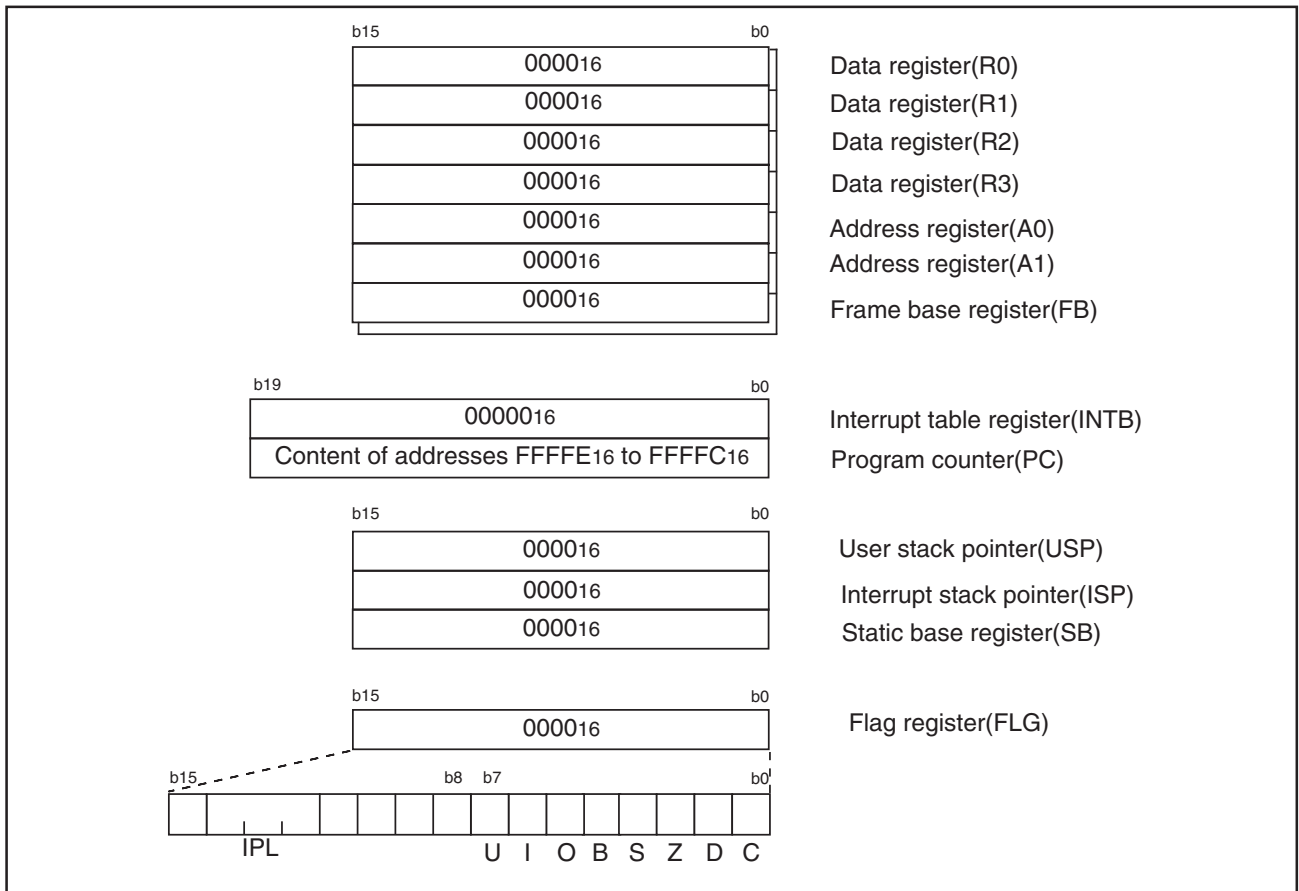

Figure 1.5.3. CPU register status after reset

Voltage detection circuit

The voltage detection circuit has monitoring circuits to check the input voltage of the VCC pin. These circuits monitor the the input voltage at VDET3 and VDET4. Bits VC26 and VC27 of VCR2 register are used to enable/disable these monitoring circuits.

The VDET3 monitoring circuit is used for detecting the minimum VCC that guarantees proper chip operation.

The VDET4 monitoring circuit can be set to detect whether the input voltage is equal to and greater or less than VDET4 depending on the value of VC13 bit of the VCR1 register. In addition, the VDET4 monitoring circuit, if enabled, can generate an interrupt.

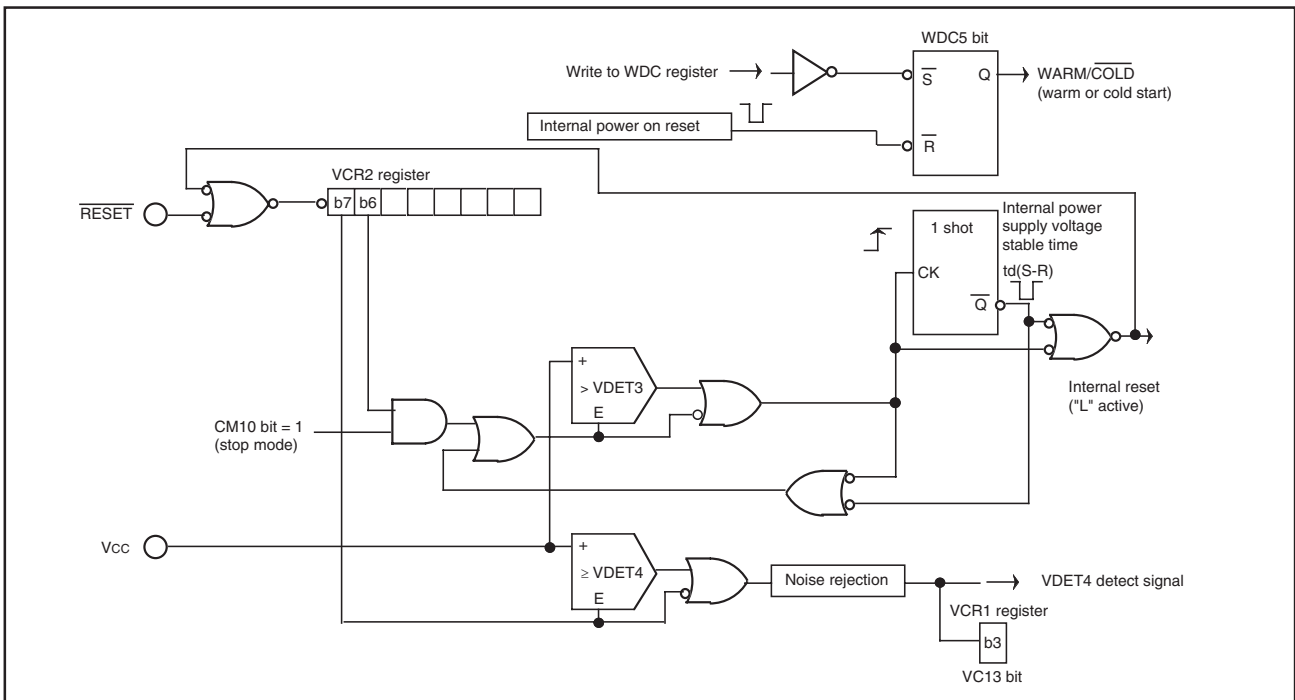

Figure 1.5.4. Reset circuit block

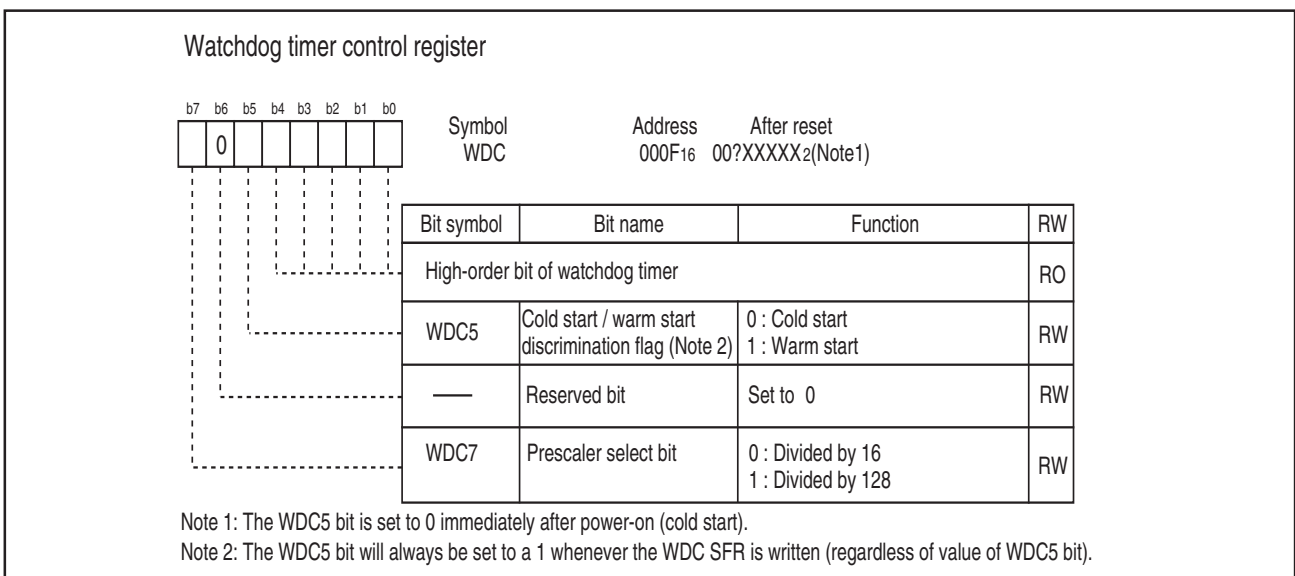
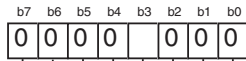

Figure 1.5.5. WDC register

Power supply detection register 1



Symbol: VCR1
Address: 0019₁₆
After reset: 00001000₂

Bit symbol	Bit name	F unction	RW
—	Reserved bit	Set to "0"	RW
VC13	VDET4 power supply monitor flag (Note)	0: VCC < VDET4 1: VCC ≥ VDET4	RO
—	Reserved bit	Set to "0"	RW

Note: The VC13 bit is useful when the VCR2 register's VC27 bit = 1 (VDET4 detection circuit enabled).
The VC13 bit is always 1 (VCC ≥ VDET4) when the VCR2 register's VC27 bit = 0 (VDET4 detection circuit disabled).

Power supply detection register 2 (Note 1)

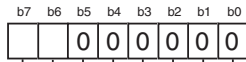

Symbol: VCR2
Address: 001A₁₆
After reset: 00₁₆

Bit symbol	Bit name	Function	RW
—	Reserved bit	Set to "0"	RW
VC26	Power supply VDET3 monitor bit	0: Disables detection circuit 1: Enables detection circuit	RW
VC27	Power supply VDET4 monitor bit (Note 2)	0: Disables detection circuit 1: Enables detection circuit	RW

Note 1: Write to this register after the PRCR register's PRC3 bit is set to "1" (write enabled).
Note 2: To use the VCR1 register's VC13 bit or D4INT register's D42 bit, set the VC27 bit to "1" (VDET4 detection circuit enabled).

Power supply VDET4 detection register (Note 1)

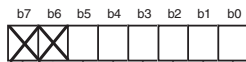

Symbol: D4INT
Address: 001F₁₆
After reset: 00₁₆

Bit symbol	Bit name	Function	RW
D40	VDET4 detection interrupt enable bit.	0: Disable 1: Enable	RW
D41	STOP mode deactivation control bit (Note 4)	0: Disable (do not use the VDET4 detection interrupt to get out of stop mode) 1: Enable (use the VDET4 detection interrupt to get out of stop mode)	RW
D42	VDET4 up/down detection flag (Note 2)	0: Not detected 1: VDET4 up/down detected	RW (Note 3)
D43	WDT overflow detected flag	0: Not detected 1: Detected	RW (Note 3)
DF0	Sampling clock select bit	b5b4 00: BCLK divided by 8 01: BCLK divided by 16 10: BCLK divided by 32 11: BCLK divided by 64	RW
DF1			RW
— (b7-b6)	Nothing is assigned. In an attempt to write to these bits, write "0". The value, if read, turns out to be "0".		—

Note 1: Write to this register after the PRCR register's PRC3 bit is set to "1" (write enabled).
Note 2: Useful when the VCR2 register's VC27 bit = 1 (VDET4 detection circuit enabled). If the VC27 bit is cleared to 0 (VDET4 detection circuit disabled), the D42 bit is set to 0 (Not detected).
Note 3: This bit is cleared to "0" by writing a "0" in a program. (Writing a "1" has no effect.)
Note 4: If the VDET4 detection interrupt needs to be used to get out of stop mode again after once used for that purpose, reset the D41 bit by writing a 0 and then a 1.

Figure 1.5.6. VCR1, VCR2, and D4INT registers

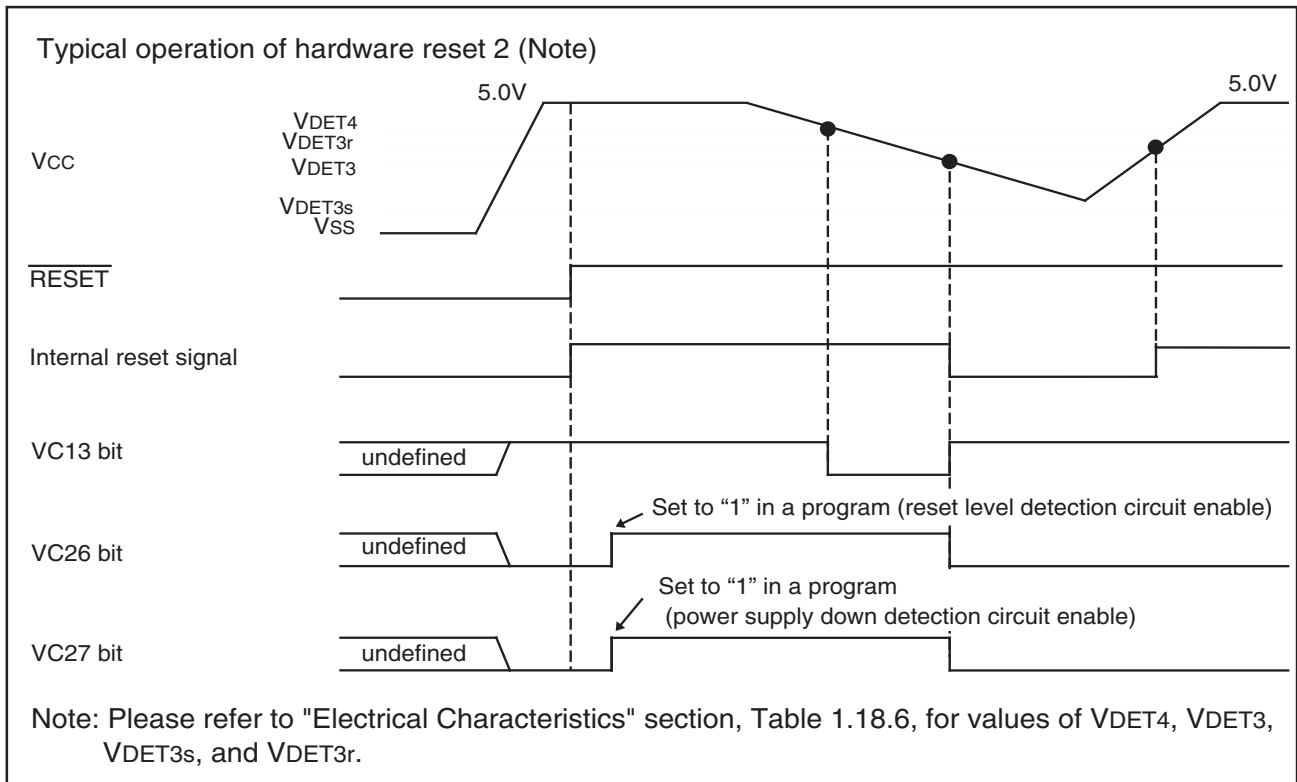

Figure 1.5.7. Typical operation of hardware reset 2

Voltage detection circuit

A VDET4 detection interrupt request is generated when the input voltage of the VCC pin rises over VDET4 or drops under VDET4 while the D40 bit of the D4INT register is equal to "1" (VDET4 detection interrupt enabled). The VDET4 detection interrupt shares the interrupt vector with the watchdog timer and oscillation stop detection interrupts.

To use the VDET4 detection interrupt as a way to get out of stop mode, set D41 bit of the D4INT register to "1" (enabled) prior to going into stop mode.

D42 bit of the the D4INT register is set to "1" when an input voltage over or under VDET4 is detected. A VDET4 detection interrupt is generated when the D42 bit changes state from "0" to "1". The D42 bit needs to be cleared to "0" in the program. However, while in stop mode, if the input voltage goes over VDET4 when the D41 bit is equal to "1", a VDET4 detection interrupt is generated regardless of the value of D42, which causes the microcomputer to get out of stop mode.

Table 1.5.2 shows the conditions under which a VDET4 detection interrupt request is generated.

The sampling clock, used for detecting when the input voltage goes over or under VDET4, is set using the DF1 and DF0 bits of the D4INT register. Table 1.5.3 shows the sampling clock periods.

Table 1.5.2. VDET4 detection interrupt request generation conditions

operation mode	VC27 bit	D40 bit	D41 bit	D42 bit	CM02 bit	VC13 bit
Normal operation mode (Note 1)	1	1	— (Note 2)	0 to 1	—	0 to 1 (Note 3)
						1 to 0 (Note 3)
Wait mode (Note 4)			—	0 to 1	0	0 to 1 (Note 3)
						1 to 0 (Note 3)
Stop mode (Note 4)	—	1	—	1	0 to 1	
					0	0 to 1

Note 1: The status is handled as normal mode when not in wait or stop modes. (Refer to "Clock Generating Circuit".)

Note 2: "—" implies either "0" or "1".

Note 3: An interrupt request for voltage reduction is generated a sampling time after the value of the VC13 bit has changed. Refer to Figure 1.5.9 "VDET4 detection interrupt generation circuit operation example" for details.

Note 4: Refer to "Limitations on stop mode", "Limitations on wait instructions with peripheral clocks turned off".

Table 1.5.3. Sampling clock periods

BCLK (MHz)	Sampling time (μs)			
	DF1 to DF0=00 (BCLK divided by 8)	DF1 to DF0=01 (BCLK divided by 16)	DF1 to DF0=10 (BCLK divided by 32)	DF1 to DF0=11 (BCLK divided by 64)
16	3.0	6.0	12.0	24.0

Precautions

1. Limitations on stop mode

With the VC13 bit of the VCR1 register equal to "1" ($V_{CC} \geq V_{DET4}$), VC27 bit of the VCR2 register equal to "1" (VDET4 detection circuit enabled), and D40 bit of the D4INT register equal to "1" (VDET4 detection interrupt enabled), if the CM10 bit of the CM1 register is set to "1" (stop mode), a VDET4 detection interrupt is immediately generated, causing the microcomputer to get out of stop mode. In systems where the microcomputer enters the stop mode when the input voltage in the VCC pin drops under VDET4 and exits from stop mode when the input voltage goes over VDET4, ensure that the CM10 bit is set to "1" when VC13 = "0" ($V_{CC} < V_{DET4}$).

2. Limitations on wait instructions with peripheral clocks turned off

If the WAIT instruction is executed when bit VC13 of the VCR1 register is equal to “1” ($V_{CC} \geq V_{DET4}$), bit VC27 of the VCR2 register is equal to “1” (V_{DET4} detection circuit enabled), and bit D40 of the D4INT register is equal to “1” (V_{DET4} detection interrupt enabled), a V_{DET4} detection interrupt is immediately generated, causing the microcomputer to exit from wait mode.

In systems where the microcomputer enters wait mode when the input voltage in the VCC pin drops under V_{DET4} and exits from wait mode when the input voltage goes over V_{DET4} , ensure that the WAIT instruction is executed when VC13 = “0” ($V_{CC} < V_{DET4}$).

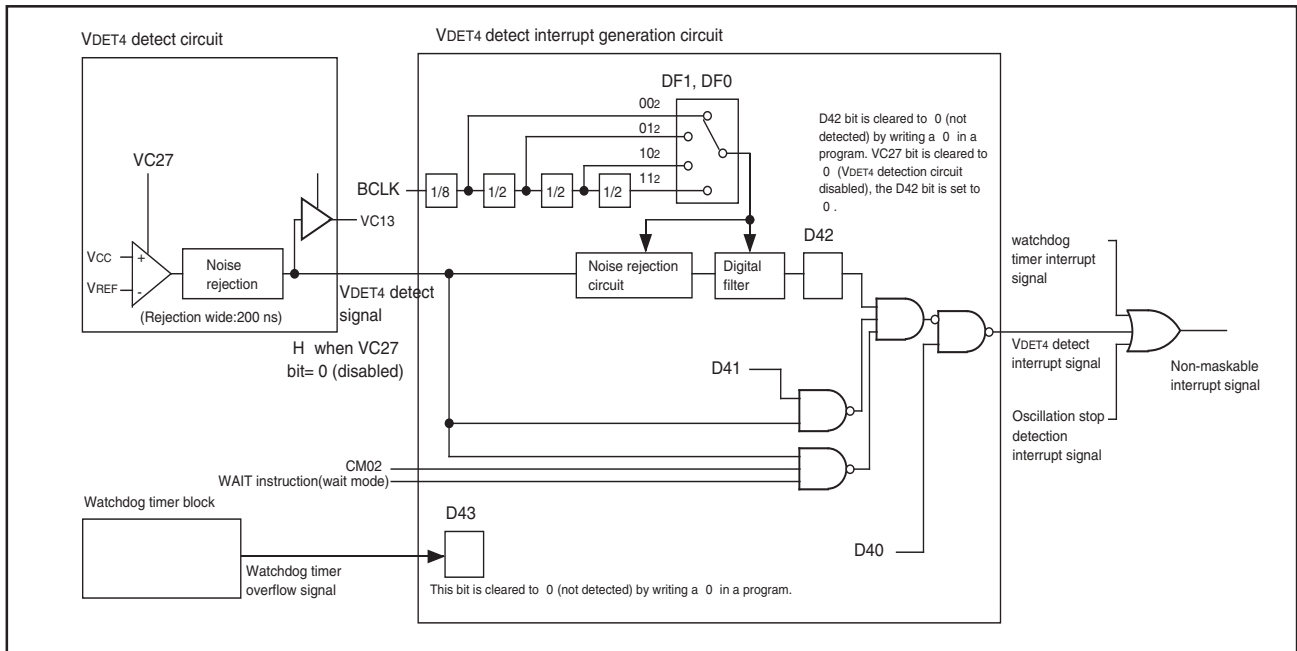

Figure 1.5.8. VDET4 detection interrupt generation block

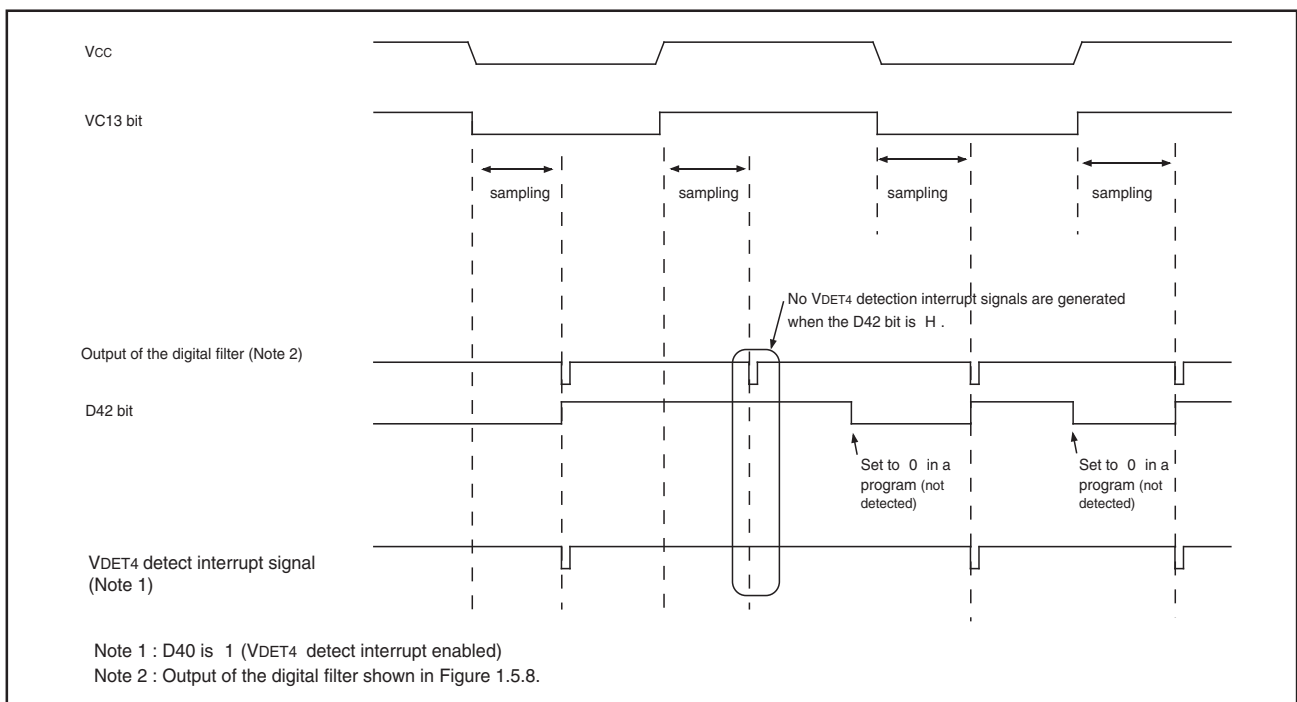

Figure 1.5.9. VDET4 detection interrupt generation circuit operation example

Special Function Registers

Figures 1.6.1 through 1.6.5 display special function register (SFR) names, addresses, acronyms, and reset values.

Address	Register Name	Acronym	Value after Reset
0000 ₁₆			
0001 ₁₆			
0002 ₁₆			
0003 ₁₆			
0004 ₁₆	Processor mode register 0	PM0	0 0 0 0 0 0 0 0
0005 ₁₆	Processor mode register 1	PM1	0 0 0 0 1 0 0 0
0006 ₁₆	System clock control register 0	CM0	0 1 0 0 1 0 0 0
0007 ₁₆	System clock control register 1	CM1	0 0 1 0 0 0 0 0
0008 ₁₆			
0009 ₁₆	Address match interrupt enable register	AIER	0 0 0 0 0 0 0 0
000A ₁₆	Protect register	PRCR	0 0 0 0 0 0 0 0
000B ₁₆			
000C ₁₆	Oscillation stop detection register	CM2	0 0 0 0 0 0 0 0
000D ₁₆			
000E ₁₆	Watchdog timer start register	WDTS	?
000F ₁₆	Watchdog timer control register	WDC	0 0 ? ? ? ? ? ?
0010 ₁₆	Address match interrupt register 0 (low)	RMAD0	00 ₁₆
0011 ₁₆	Address match interrupt register 0 (mid)		00 ₁₆
0012 ₁₆	Address match interrupt register 0 (high)		0 0 0 0
0013 ₁₆			
0014 ₁₆	Address match interrupt register 1 (low)	RMAD1	00 ₁₆
0015 ₁₆	Address match interrupt register 1 (mid)		00 ₁₆
0016 ₁₆	Address match interrupt register 1 (high)		0 0 0 0
0017 ₁₆			
0018 ₁₆			
0019 ₁₆	Power supply detection register 1	VCR1	0 0 0 0 1 0 0 0
001A ₁₆	Power supply detection register 2	VCR2	0 0 0 0 0 0 0 0
001B ₁₆			
001C ₁₆			
001D ₁₆			
001E ₁₆	Processor mode register 2	PM2	0 0 0 0 0 0 0 0
001F ₁₆	Power supply 4 V detection register	D4INT	0 0 0 0 0 0 0 0
0020 ₁₆	DMA0 source pointer (low)	SAR0	?
0021 ₁₆	DMA0 source pointer (mid)		?
0022 ₁₆	DMA0 source pointer (high)		? ? ? ?
0023 ₁₆			
0024 ₁₆	DMA0 destination pointer (low)	DAR0	?
0025 ₁₆	DMA0 destination pointer (mid)		?
0026 ₁₆	DMA0 destination pointer (high)		? ? ? ?
0027 ₁₆			
0028 ₁₆	DMA0 transfer counter (low)	TCR0	?
0029 ₁₆	DMA0 transfer counter (high)		?
002A ₁₆			
002B ₁₆			
002C ₁₆	DMA0 control register	DM0CON	0 0 0 0 0 ? 0 0
002D ₁₆			
002E ₁₆			
002F ₁₆			
0030 ₁₆	DMA1 source pointer (low)	SAR1	?
0031 ₁₆	DMA1 source pointer (mid)		?
0032 ₁₆	DMA1 source pointer (high)		? ? ? ?
0033 ₁₆			
0034 ₁₆	DMA1 destination pointer (low)	DAR1	?
0035 ₁₆	DMA1 destination pointer (mid)		?
0036 ₁₆	DMA1 destination pointer (high)		? ? ? ?
0037 ₁₆			
0038 ₁₆	DMA1 transfer counter (low)	TCR1	?
0039 ₁₆	DMA1 transfer counter (high)		?
003A ₁₆			
003B ₁₆			
003C ₁₆	DMA1 control register	DM1CON	0 0 0 0 0 ? 0 0
003D ₁₆			
003E ₁₆			
003F ₁₆			

□	Reserved address, do not write
?	Value indeterminate at reset
0	reset value is zero
1	reset value is one
0	reserved bit, must write to zero
1	reserved bit, must write to one
□	Nothing is mapped to this bit (value is indeterminate when read)

Figure 1.6.1. Location of peripheral unit control registers (1)

Address	Register Name	Acronym	Value after Reset
0040 ₁₆			
0041 ₁₆			
0042 ₁₆			
0043 ₁₆			
0044 ₁₆	INT3 interrupt control register	INT3IC	0 0 ? 0 0 0
0045 ₁₆			
0046 ₁₆			
0047 ₁₆			
0048 ₁₆	INT5 interrupt control register	INT5IC	0 0 ? 0 0 0
0049 ₁₆	INT4 interrupt control register	INT4IC	0 0 ? 0 0 0
004A ₁₆	Bus collision detection interrupt control register	BCNIC	? 0 0 0
004B ₁₆	DMA0 interrupt control register	DM0IC	? 0 0 0
004C ₁₆	DMA1 interrupt control register	DM1IC	? 0 0 0
004D ₁₆	Key input interrupt control register	KUPIC	? 0 0 0
004E ₁₆	A-D conversion interrupt control register	ADIC	? 0 0 0
004F ₁₆	UART2 transmit interrupt control register	S2TIC	? 0 0 0
0050 ₁₆	UART2 receive interrupt control register	S2RIC	? 0 0 0
0051 ₁₆	UART0 transmit interrupt control register	S0TIC	? 0 0 0
0052 ₁₆	UART0 receive interrupt control register	S0RIC	? 0 0 0
0053 ₁₆	UART1 transmit interrupt control register	S1TIC	? 0 0 0
0054 ₁₆	UART1 receive interrupt control register	S1RIC	? 0 0 0
0055 ₁₆	Timer A0 interrupt control register	TA0IC	? 0 0 0
0056 ₁₆	Timer A1 interrupt control register	TA1IC	? 0 0 0
0057 ₁₆	Timer A2 interrupt control register	TA2IC	? 0 0 0
0058 ₁₆	Timer A3 interrupt control register	TA3IC	? 0 0 0
0059 ₁₆	Timer A4 interrupt control register	TA4IC	? 0 0 0
005A ₁₆	Timer B0 interrupt control register	TB0IC	? 0 0 0
005B ₁₆	Timer B1 interrupt control register	TB1IC	? 0 0 0
005C ₁₆	Timer B2 interrupt control register	TB2IC	? 0 0 0
005D ₁₆	INT0 interrupt control register	INT0IC	0 0 ? 0 0 0
005E ₁₆	INT1 interrupt control register	INT1IC	0 0 ? 0 0 0
005F ₁₆			
to			
01B3 ₁₆	Flash Control Register 4	FMR4	0 1 0 0 0 0 0 0
01B4 ₁₆			
01B5 ₁₆	Flash Control Register 1	FMR1	0 0 0 1 0 1
01B6 ₁₆			
01B7 ₁₆	Flash Control Register 0	FMR0	0 0 0 0 0 0 0 1
01B8 ₁₆			
01B9 ₁₆			
01BA ₁₆			
01BB ₁₆			
01BC ₁₆			
01BD ₁₆			
01BE ₁₆			
01BF ₁₆			
01C0 ₁₆			
01C1 ₁₆			
01C2 ₁₆			
to			
025C ₁₆			
025D ₁₆			
025E ₁₆	Peripheral Clock Select Register	PLCKR	0 0 0 0 0 0 1 1
025F ₁₆			
0260 ₁₆			
to			
033E ₁₆			
033F ₁₆			

□	Reserved address, do not write
?	Value indeterminate at reset
0	reset value is zero
1	reset value is one
0	reserved bit, must write to zero
1	reserved bit, must write to one
□	Nothing is mapped to this bit (value is indeterminate when read)

Figure 1.6.2. Location of peripheral unit control registers (2)

Address	Register Name	Acronym	Value after Reset
0340 ₁₆			
0341 ₁₆			
0342 ₁₆	Timer A1-1 register (low)	TA11	?
0343 ₁₆	Timer A1-1 register (high)		?
0344 ₁₆	Timer A2-1 register (low)	TA21	?
0345 ₁₆	Timer A2-1 register (high)		?
0346 ₁₆	Timer A4-1 register (low)	TA41	?
0347 ₁₆	Timer A4-1 register (high)		?
0348 ₁₆	Three-phase PWM control register 0	INVC0	0 0 0 0 0 0 0 0
0349 ₁₆	Three-phase PWM control register 1	INVC1	0 0 0 0 0 0 0 0
034A ₁₆	Three-phase output buffer register 0	IDB0	0 0 0 0 0 0 0 0
034B ₁₆	Three-phase output buffer register 1	IDB1	0 0 0 0 0 0 0 0
034C ₁₆	Dead time timer	DTT	?
034D ₁₆	Timer B2 interrupt occurrences frequency set counter	ICTB2	? ? ? ? ? ? ? ?
034E ₁₆			
034F ₁₆			
0350 ₁₆			
0351 ₁₆			
0352 ₁₆			
0353 ₁₆			
0354 ₁₆			
0355 ₁₆			
0356 ₁₆			
0357 ₁₆			
0358 ₁₆			
0359 ₁₆			
035A ₁₆			
035B ₁₆			
035C ₁₆			
035D ₁₆			
035E ₁₆			
035F ₁₆	Interrupt request cause select register	IFSR	0 0 0 0 0 0 0 0
0360 ₁₆			
0361 ₁₆			
0362 ₁₆			
0363 ₁₆			
0364 ₁₆			
0365 ₁₆			
0366 ₁₆			
0367 ₁₆			
0368 ₁₆			
0369 ₁₆			
036A ₁₆			
036B ₁₆			
036C ₁₆			
036D ₁₆			
036E ₁₆			
036F ₁₆			
0370 ₁₆			
0371 ₁₆			
0372 ₁₆			
0373 ₁₆			
0374 ₁₆	UART2 special mode register 4	U2SMR4	0 0 0 0 0 0 0 0
0375 ₁₆	UART2 special mode register 3	U2SMR3	0 0 0 0 0 0
0376 ₁₆	UART2 special mode register 2	U2SMR2	0 0 0 0 0 0 0 0
0377 ₁₆	UART2 special mode register	U2SMR	0 0 0 0 0 0 0 0
0378 ₁₆	UART2 transmit/receive mode register	U2MR	0 0 0 0 0 0 0 0
0379 ₁₆	UART2 bit rate generator	U2BRG	?
037A ₁₆	UART2 transmit buffer register (low)	U2TB	?
037B ₁₆	UART2 transmit buffer register (high)		? ? ? ? ? ? ? ?
037C ₁₆	UART2 transmit/receive control register 0	U2C0	0 0 0 0 1 0 0 0
037D ₁₆	UART2 transmit/receive control register 1	U2C1	0 0 0 0 0 0 1 0
037E ₁₆	UART2 receive buffer register (low)	U2RB	?
037F ₁₆	UART2 receive buffer register (high)		? ? ? ? ? ? ? ?

	Reserved address, do not write
?	Value indeterminate at reset
0	reset value is zero
1	reset value is one
0	reserved bit, must write to zero
1	reserved bit, must write to one
	Nothing is mapped to this bit (value is indeterminate when read)

Figure 1.6.3. Location of peripheral unit control registers (3)

Address	Register Name	Acronym	Value after Reset
0380 ₁₆	Count start flag	TABSR	0 0 0 0 0 0 0 0
0381 ₁₆	Clock prescaler reset flag	CPSRF	0
0382 ₁₆	One-shot start flag	ONSF	0 0 0 0 0 0 0 0
0383 ₁₆	Trigger select register	TRGSR	0 0 0 0 0 0 0 0
0384 ₁₆	Up/down flag	UDF	0 0 0 0 0 0 0 0
0385 ₁₆			
0386 ₁₆	Timer A0 register (low)	TA0	?
0387 ₁₆	Timer A0 register (high)		?
0388 ₁₆	Timer A1 register (low)	TA1	?
0389 ₁₆	Timer A1 register (high)		?
038A ₁₆	Timer A2 register (low)	TA2	?
038B ₁₆	Timer A2 register (high)		?
038C ₁₆	Timer A3 register (low)	TA3	?
038D ₁₆	Timer A3 register (high)		?
038E ₁₆	Timer A4 register (low)	TA4	?
038F ₁₆	Timer A4 register (high)		?
0390 ₁₆	Timer B0 register (low)	TB0	?
0391 ₁₆	Timer B0 register (high)		?
0392 ₁₆	Timer B1 register (low)	TB1	?
0393 ₁₆	Timer B1 register (high)		?
0394 ₁₆	Timer B2 register (low)	TB2	?
0395 ₁₆	Timer B2 register (high)		?
0396 ₁₆	Timer A0 mode register	TA0MR	0 0 0 0 0 0 0 0
0397 ₁₆	Timer A1 mode register	TA1MR	0 0 0 0 0 0 0 0
0398 ₁₆	Timer A2 mode register	TA2MR	0 0 0 0 0 0 0 0
0399 ₁₆	Timer A3 mode register	TA3MR	0 0 0 0 0 0 0 0
039A ₁₆	Timer A4 mode register	TA4MR	0 0 0 0 0 0 0 0
039B ₁₆	Timer B0 mode register	TB0MR	0 0 ? ? 0 0 0 0
039C ₁₆	Timer B1 mode register	TB1MR	0 0 ? ? 0 0 0 0
039D ₁₆	Timer B2 mode register	TB2MR	0 0 ? ? 0 0 0 0
039E ₁₆	Timer B2 special mode register	TB2SC	?
039F ₁₆			
03A0 ₁₆	UART0 transmit/receive mode register	U0MR	0 0 0 0 0 0 0 0
03A1 ₁₆	UART0 bit rate generator	U0BRG	?
03A2 ₁₆	UART0 transmit buffer register (low)	U0TB	?
03A3 ₁₆	UART0 transmit buffer register (high)		?
03A4 ₁₆	UART0 transmit/receive control register 0	U0C0	0 0 0 0 1 0 0 0
03A5 ₁₆	UART0 transmit/receive control register 1	U0C1	0 0 0 0 0 0 1 0
03A6 ₁₆	UART0 receive buffer register (low)	U0RB	?
03A7 ₁₆	UART0 receive buffer register (high)		?
03A8 ₁₆	UART1 transmit/receive mode register	U1MR	0 0 0 0 0 0 0 0
03A9 ₁₆	UART1 bit rate generator	U1BRG	?
03AA ₁₆	UART1 transmit buffer register (low)	U1TB	?
03AB ₁₆	UART1 transmit buffer register (high)		?
03AC ₁₆	UART1 transmit/receive control register 0	U1C0	0 0 0 0 1 0 0 0
03AD ₁₆	UART1 transmit/receive control register 1	U1C1	0 0 0 0 0 0 1 0
03AE ₁₆	UART1 receive buffer register (low)	U1RB	?
03AF ₁₆	UART1 receive buffer register (high)		?
03B0 ₁₆	UART transmit/receive control register 2	UCON	0 0 0 0 0 0 0 0
03B1 ₁₆			
03B2 ₁₆			
03B3 ₁₆			
03B4 ₁₆			
03B5 ₁₆			
03B6 ₁₆			
03B7 ₁₆			
03B8 ₁₆	DMA0 request cause select register	DM0SL	0 0 ? ? 0 0 0 0
03B9 ₁₆			
03BA ₁₆	DMA1 request cause select register	DM1SL	0 0 ? ? 0 0 0 0
03BB ₁₆			
03BC ₁₆			
03BD ₁₆			
03BE ₁₆			
03BF ₁₆			

□	Reserved address, do not write
?	Value indeterminate at reset
0	reset value is zero
1	reset value is one
0	reserved bit, must write to zero
1	reserved bit, must write to one
□	Nothing is mapped to this bit (value is indeterminate when read)

Figure 1.6.4. Location of peripheral unit control registers (4)

Address	Register Name	Acronym	Value after Reset
03C0 ₁₆	A-D register 0 (low)	AD0	?
03C1 ₁₆	A-D register 0 (high)		??
03C2 ₁₆	A-D register 1 (low)	AD1	?
03C3 ₁₆	A-D register 1 (high)		??
03C4 ₁₆	A-D register 2 (low)	AD2	?
03C5 ₁₆	A-D register 2 (high)		??
03C6 ₁₆	A-D register 3 (low)	AD3	?
03C7 ₁₆	A-D register 3 (high)		??
03C8 ₁₆	A-D register 4 (low)	AD4	?
03C9 ₁₆	A-D register 4 (high)		??
03CA ₁₆	A-D register 5 (low)	AD5	?
03CB ₁₆	A-D register 5 (high)		??
03CC ₁₆	A-D register 6 (low)	AD6	?
03CD ₁₆	A-D register 6 (high)		??
03CE ₁₆	A-D register 7 (low)	AD7	?
03CF ₁₆	A-D register 7 (high)		??
03D0 ₁₆			
03D1 ₁₆			
03D2 ₁₆			
03D3 ₁₆			
03D4 ₁₆	A-D control register 2	ADCON2	00000000
03D5 ₁₆			
03D6 ₁₆	A-D control register 0	ADCON0	00000???
03D7 ₁₆	A-D control register 1	ADCON1	00000000
03D8 ₁₆			
03D9 ₁₆			
03DA ₁₆			
03DB ₁₆			
03DC ₁₆			
03DD ₁₆			
03DE ₁₆			
03DF ₁₆			
03E0 ₁₆			
03E1 ₁₆	Port P1 register	P1	?? ? 000000
03E2 ₁₆			
03E3 ₁₆	Port P1 direction register	PD1	00000000
03E4 ₁₆			
03E5 ₁₆			
03E6 ₁₆			
03E7 ₁₆			
03E8 ₁₆			
03E9 ₁₆			
03EA ₁₆			
03EB ₁₆			
03EC ₁₆	Port P6 register	P6	?? ? ? ? ? ? ?
03ED ₁₆	Port P7 register	P7	?? ? ? ? ? ? ?
03EE ₁₆	Port P6 direction register	PD6	00000000
03EF ₁₆	Port P7 direction register	PD7	00000000
03F0 ₁₆	Port P8 register	P8	?? ? 0 ? ? ? ?
03F1 ₁₆	Port P9 register	P9	0000 ? ? ? ?
03F2 ₁₆	Port P8 direction register	PD8	00000000
03F3 ₁₆	Port P9 direction register	PD9	00000000
03F4 ₁₆	Port P10 register	P10	?? ? ? ? ? ? ?
03F5 ₁₆			
03F6 ₁₆	Port P10 direction register	PD10	00000000
03F7 ₁₆			
03F8 ₁₆			
03F9 ₁₆			
03FA ₁₆			
03FB ₁₆			
03FC ₁₆	Pull-up control register 0	PUR0	00000000
03FD ₁₆	Pull-up control register 1	PUR1	00000000
03FE ₁₆	Pull-up control register 2	PUR2	00000000
03FF ₁₆	Port control register	PCR	00000000

	Reserved address, do not write
?	Value indeterminate at reset
0	reset value is zero
1	reset value is one
0	reserved bit, must write to zero
1	reserved bit, must write to one
	Nothing is mapped to this bit (value is indeterminate when read)

Figure 1.6.5. Location of peripheral unit control registers (5)

Processor Mode

This device functions in single-chip mode only. In single-chip mode, only internal memory space (SFR, internal RAM, and internal ROM) can be accessed. Ports P1_5 to P1_7, P6, P7, P8, P9_0 to P9_3 and P10 can be used as programmable I/O ports or as I/O ports for the internal peripheral functions. Figure 1.7.1 shows the processor mode registers 0 and 1. Figure 1.7.2 shows the processor mode register 2.

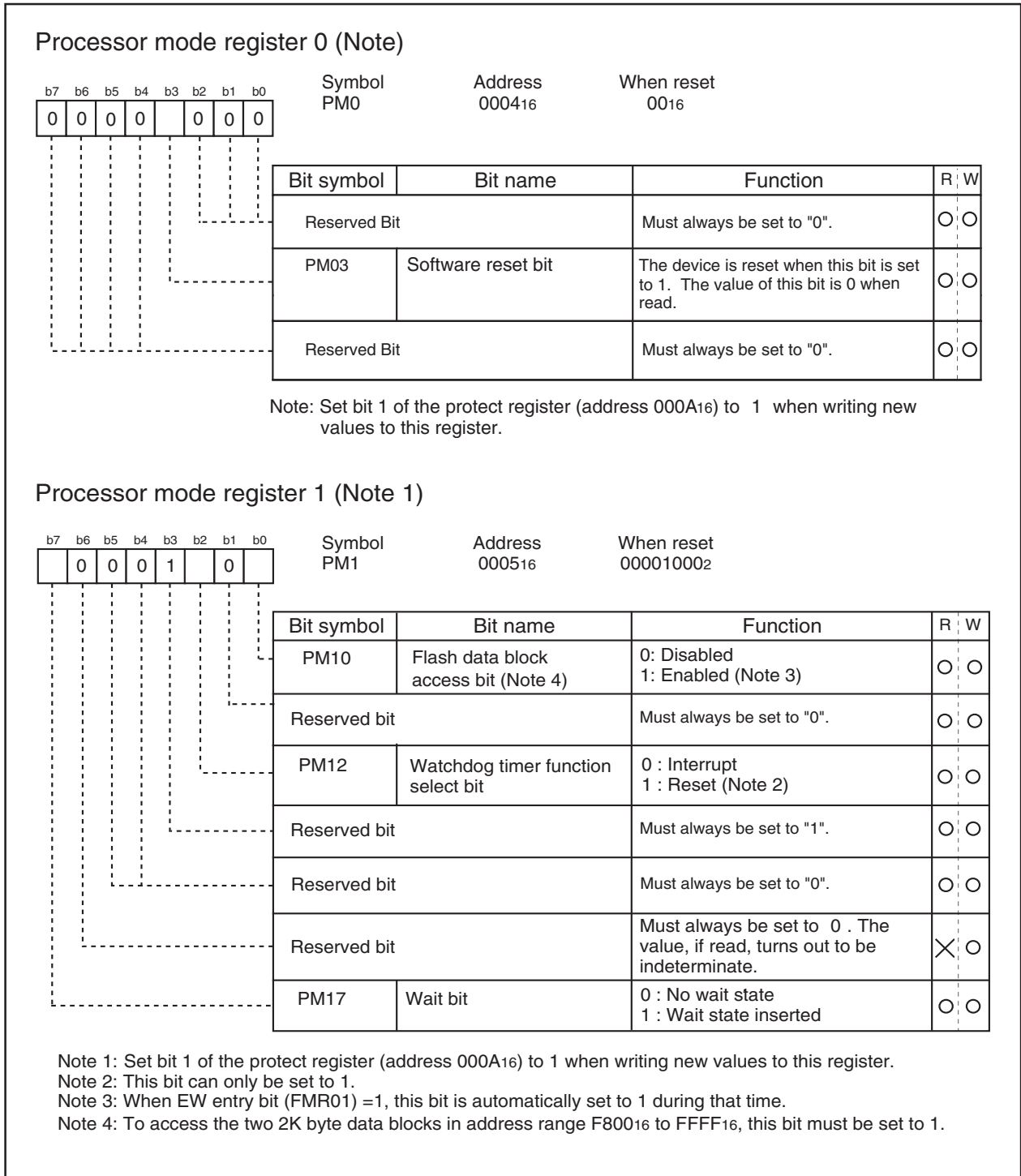

Figure 1.7.1. Processor mode register 0 and 1

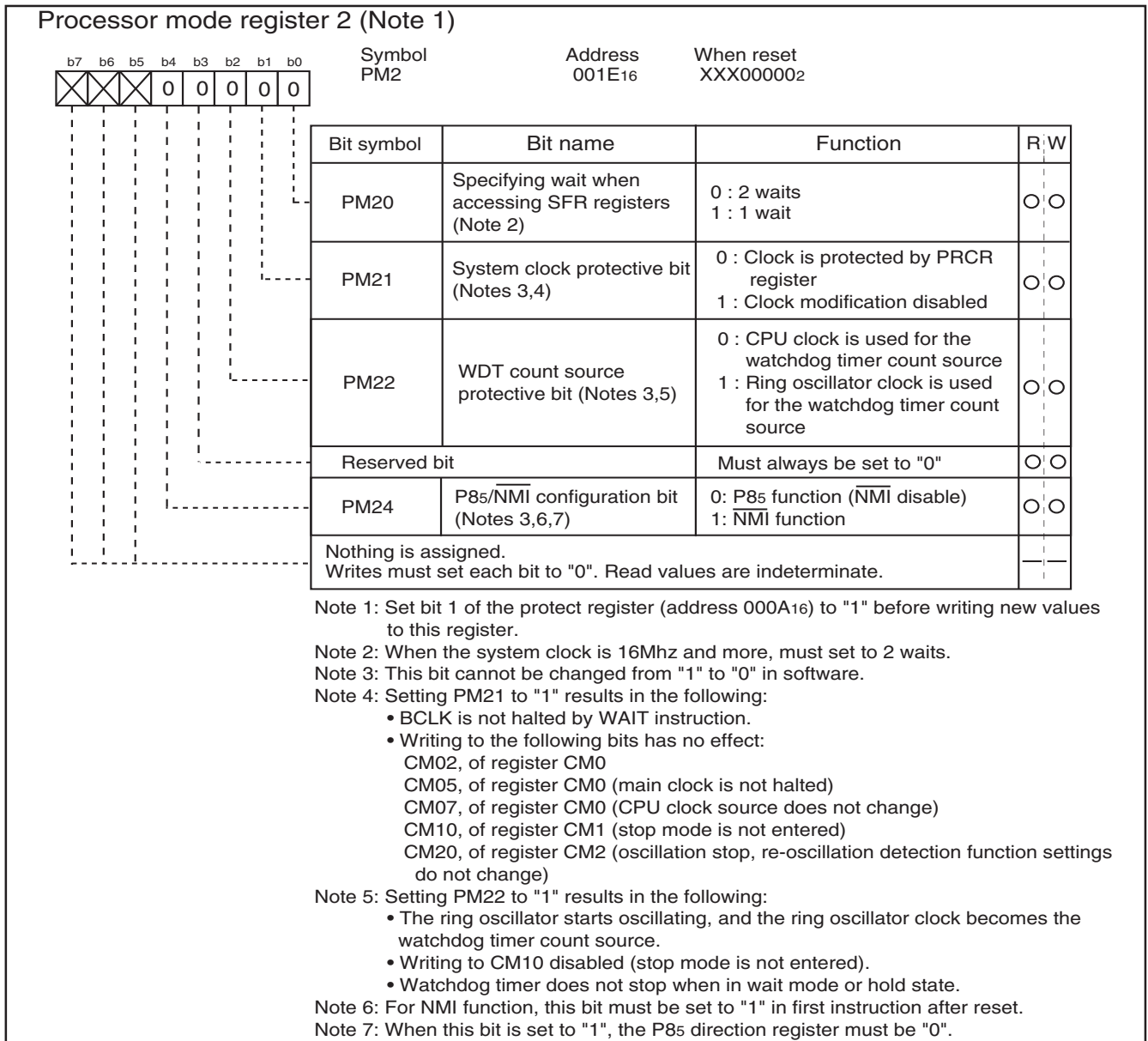

Figure 1.7.2. Processor mode register 2

Software Reset

Writing "1" to bit 3 of the processor mode register 0 (address 000416) applies a (software) reset to the microcomputer. A software reset has the same effect as a hardware reset except the contents of internal RAM are preserved after a software reset.

Note: Before attempting to change the contents of the processor mode register 0, set bit 1 of the protect register (address 000A16) to "1".

Software wait

A software wait can be inserted by setting the wait bit (bit 7) of the processor mode register 1 (address 000516) (Note) and bits 4 to 7 of the chip select control register (address 000816).

A software wait is inserted in the internal ROM/RAM area by setting the wait bit of processor mode register 1. When set to "0", each bus cycle is executed in one BCLK cycle. When set to "1", each bus cycle is executed in two BCLK cycles. After the microcomputer has been reset, this bit defaults to "0". When set to "1", a wait is applied to all memory areas (two BCLK cycles). Set this bit after referring to the recommended operating conditions (main clock input oscillation frequency) of the electrical characteristics.

The SFR area is always accessed in two BCLK cycles regardless of the setting of these control bits.

Table 1.7.1 shows the software wait and bus cycles.

Note: Before attempting to change the contents of the processor mode register 1, set bit 1 of the protect register (address 000A16) to "1".

Table 1.7.1. Software waits and bus cycles

Area	Wait bit	Bus cycle
Internal ROM/RAM	0	1 BCLK cycle
	1	2 BCLK cycles

Clock Generating Circuit

The clock generating circuit contains three oscillator circuits as follows:

- (1) Main clock generating circuit
- (2) Sub clock generating circuit
- (3) Ring oscillator

Table 1.8.1 lists the clock generating circuit specifications.

Table 1.8.1. Clock generating circuits

Example of oscillator circuit

Item	Main clock generating circuit	Sub clock generating circuit	Ring oscillator
Use of clock	- CPU's operating clock source - Internal peripheral unit's operating	- CPU's operating clock source - Timer A/B's count clock source	- CPU clock source - Peripheral function clock source - CPU and peripheral function clock source when main clock frequency stops
Usable oscillator	- Ceramic oscillator - Crystal oscillator	- Crystal oscillator	About 1MHz
Pins to connect oscillator	XIN, XOUT	XCIN, XCOUT	_____
Oscillation stop/restart function	Available	Available	Available
Oscillator status after reset	Oscillating	Stopped	Stopped
Other	Externally derived clock can be input		_____

Figure 1.8.1 shows some examples of the main clock circuit, one using an oscillator connected to the circuit, and the other one using an externally derived clock for input. Figure 1.8.2 shows some examples of sub-clock circuits, one using an oscillator connected to the circuit, and the other one using an externally derived clock for input. Circuit constants in Figures 1.8.1 and 1.8.2 vary with each oscillator used. Use the values recommended by the manufacturer of your oscillator.

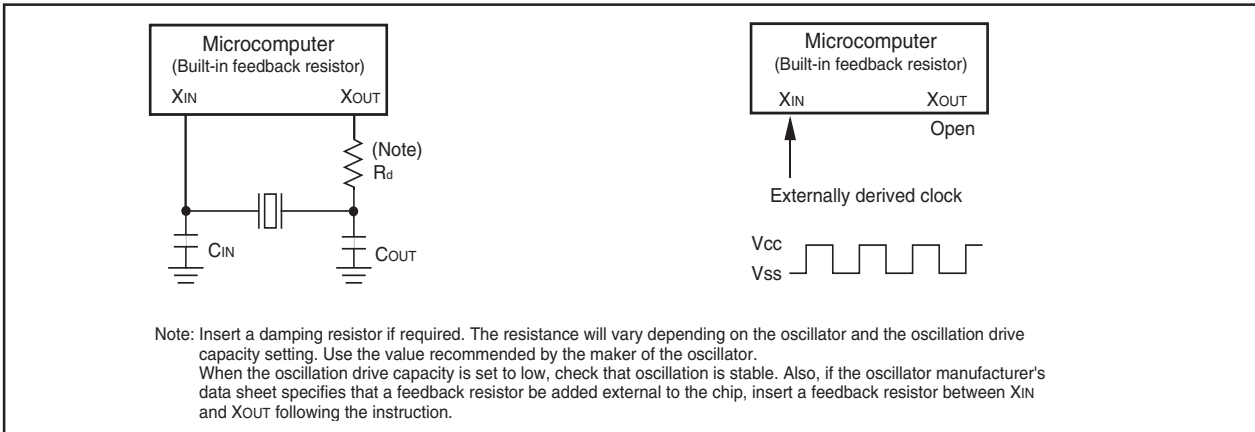

Figure 1.8.1. Examples of main clock

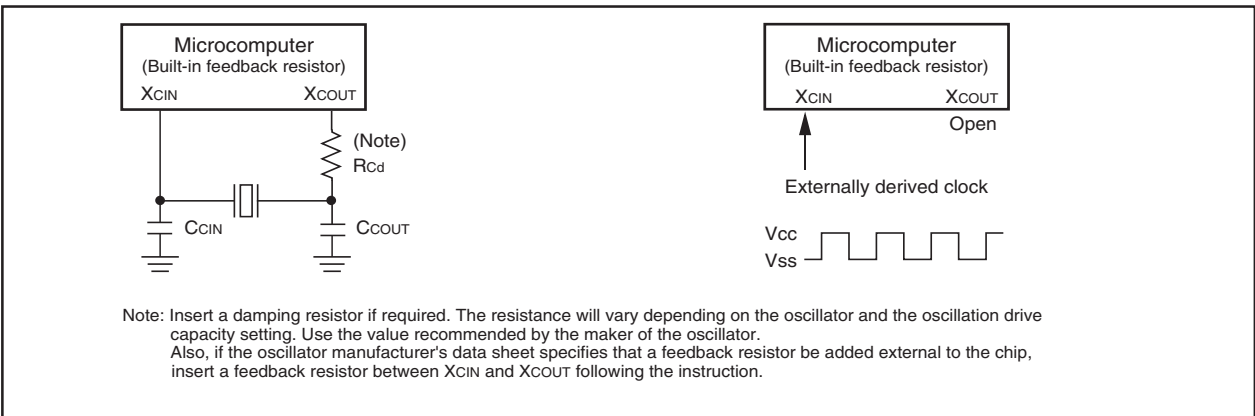

Figure 1.8.2. Examples of sub-clock

Clock Control

Figure 1.8.3 shows the block diagram of the clock generating circuit.

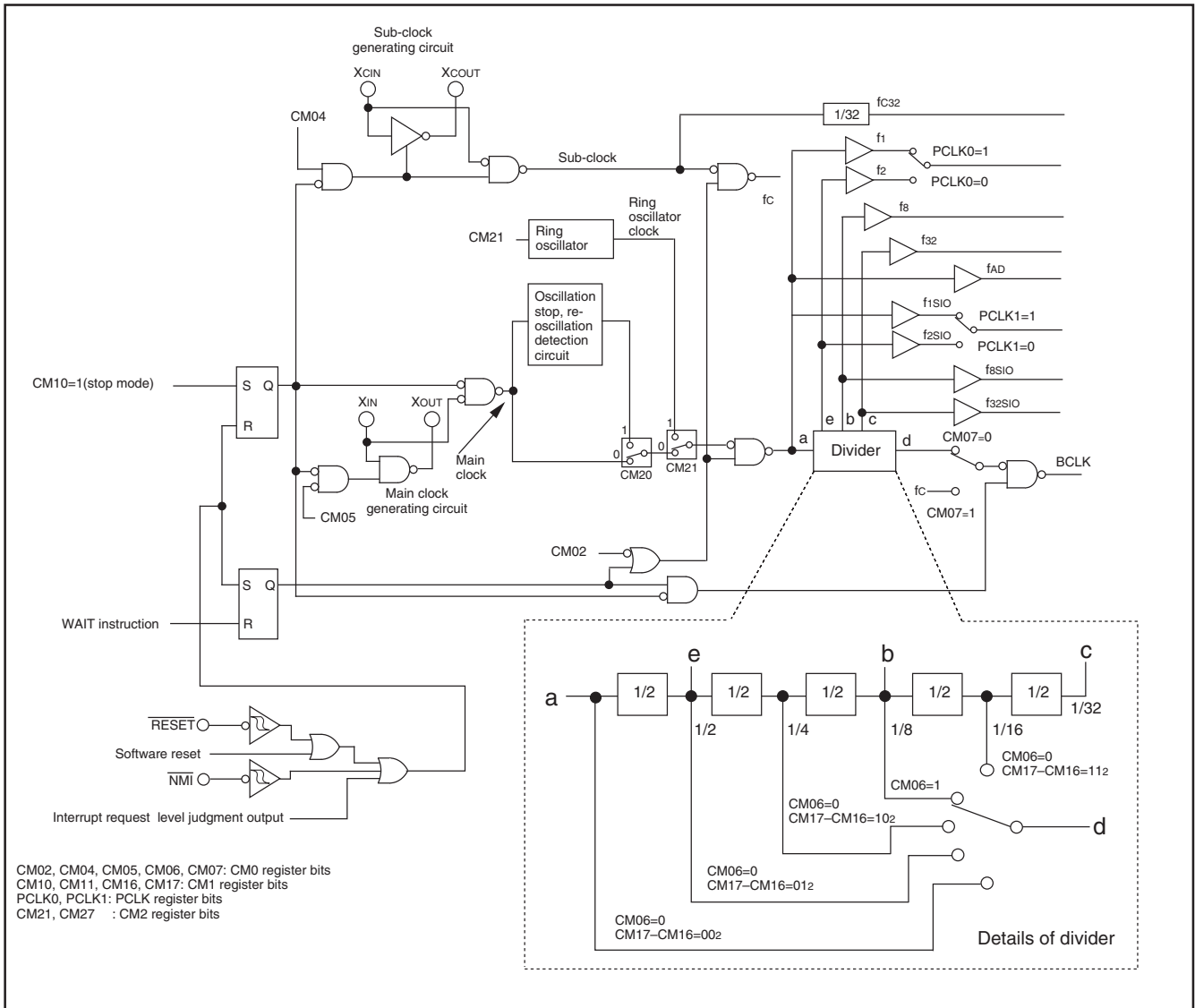

Figure 1.8.3. Clock generating circuit

The following paragraphs describes the clocks generated by the clock generating circuit.

(1) Main clock

The main clock is generated by the main clock oscillation circuit. After a reset, the clock is divided by 8 to the BCLK. The clock can be stopped using the main clock stop bit (bit 5 at address 0006₁₆). Stopping the clock, after switching the operating clock source of CPU to the sub-clock, reduces the power dissipation. After the oscillation of the main clock oscillation circuit has stabilized, the drive capacity of the main clock oscillation circuit can be reduced using the X_{IN}-X_{OUT} drive capacity select bit (bit 5 at address 0007₁₆). Reducing the drive capacity of the main clock oscillation circuit reduces the power dissipation. This bit changes to "1" when shifting from high-speed/medium-speed mode to stop mode, shifting to low power dissipation mode and at a reset. When shifting from high-speed/medium-speed mode to low-speed mode, the value before high-speed/medium-speed mode is retained.

(2) Sub-clock

The sub-clock is generated by the sub-clock oscillation circuit. No sub-clock is generated after a reset. After oscillation is started using the port Xc select bit (bit 4 at address 0006₁₆), the sub-clock can be selected as the BCLK by using the system clock select bit (bit 7 at address 0006₁₆). However, be sure that the sub-clock oscillation has fully stabilized before switching.

After the oscillation of the sub-clock oscillation circuit has stabilized, the drive capacity of the sub-clock oscillation circuit can be reduced using the X_{CIN}-X_{COUT} drive capacity select bit (bit 3 at address 0006₁₆). Reducing the drive capacity of the sub-clock oscillation circuit reduces the power dissipation. This bit changes to "1" when the port Xc select bit (bit 4 at address 0006₁₆) is set to "0", shifting to stop mode and at a reset.

When the X_{CIN}/X_{COUT} is used, set ports P8₆ and P8₇ as the input ports without pull-up.

(3) BCLK

The BCLK is the clock that drives the CPU, and is fc or the clock is derived by dividing the main clock by 1, 2, 4, 8, or 16. The BCLK is derived by dividing the main clock by 8 after a reset.

The main clock division select bit 0 (bit 6 at address 0006₁₆) changes to "1" when shifting from high-speed/medium-speed to stop mode, shifting to low power dissipation mode and at reset. When shifting from high-speed/medium-speed mode to low-speed mode, the value before high-speed/medium-speed mode is retained.

(4) Peripheral function clock(f₁, f₈, f₃₂, f_{1SIO2}, f_{8SIO2}, f_{32SIO2}, f_{AD})

The clock for the peripheral devices is derived from the main clock or by dividing it by 1, 8, or 32. The peripheral function clock is stopped by stopping the main clock or by setting the WAIT peripheral function clock stop bit (bit 2 at 0006₁₆) to "1" and then executing a WAIT instruction.

By setting the timer A, B clock select bit (bit 0 at address 001E₁₆) and SIO clock select bit (bit 1 at address 001E₁₆) to "1" respectively, f₁ and f_{1SIO2} can be changed to the main clock divided by 2.

(5) fc₃₂

This clock is derived by dividing the sub-clock by 32. It is used for the timer A and timer B counts.

(6) fc

This clock has the same frequency as the sub-clock. It is used for the BCLK and for the watchdog timer. Figure 1.8.4a shows the system clock control registers 0 and 1 and Figure 1.8.4b shows peripheral clock select register.

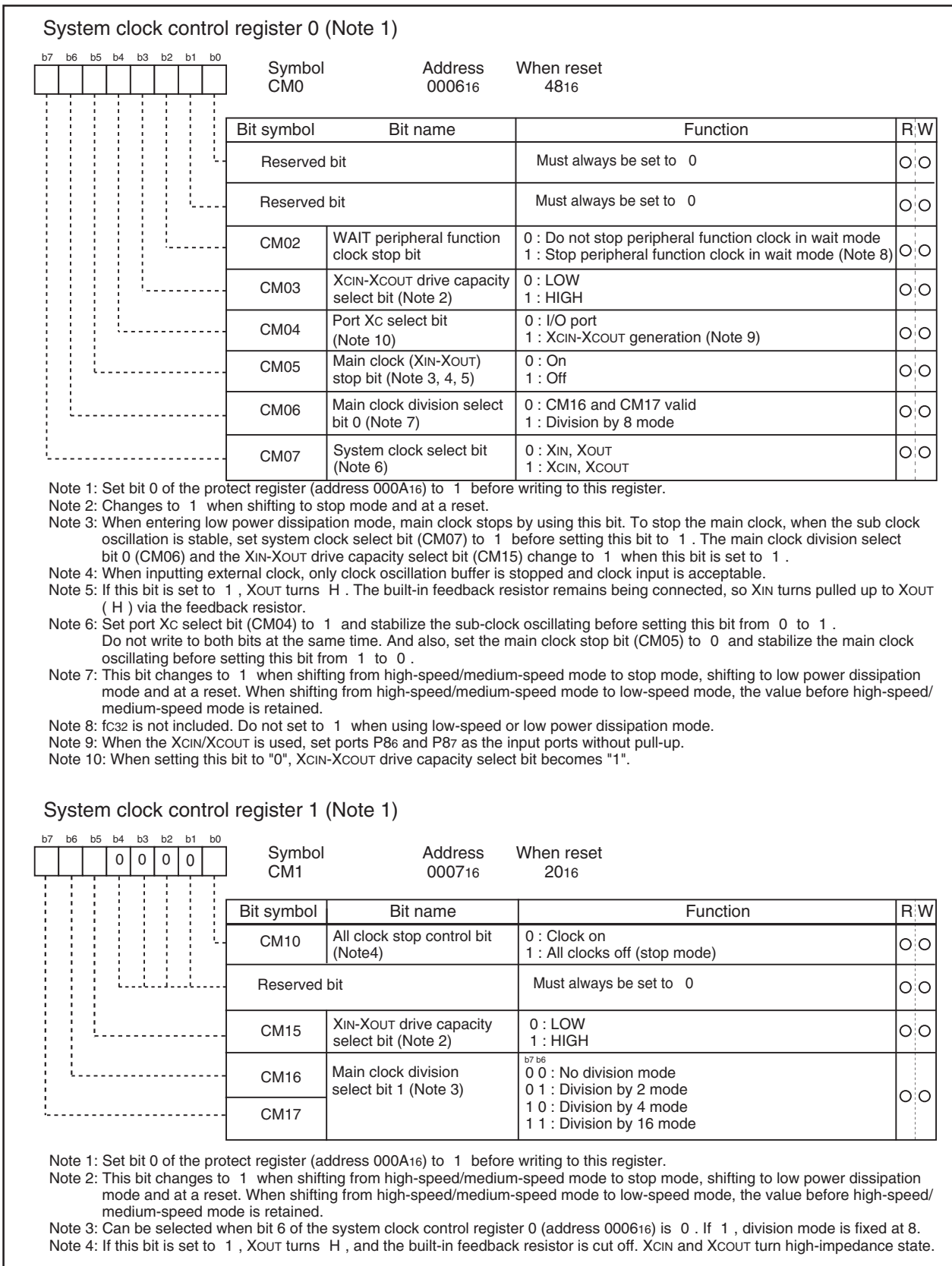
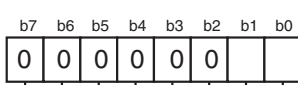

Figure 1.8.4a. Clock control registers 0 and 1

Peripheral clock select register (Note)



Symbol PCLKR Address 025E16 When reset 0316

Bit symbol	Bit name	Function	R	W
PCLK0	Timers A, B clock select bit (Clock source for the timers A, B, and the dead time timer)	0 : f2 1 : f1	○	○
PCLK1	SI/O clock select bit (Clock source for UART0 to UART2)	0 : f2SIO 1 : f1SIO	○	○
Reserved bit		Must always be set to 0	○	○

Note: Set the bit 0 of the protect register (address 000A16) to "1" before rewriting this register.

Figure 1.8.4b. Peripheral clock select register

Processor mode register 2 (Note 1)

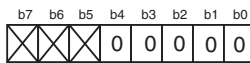

Symbol PM2 Address 001E16 When reset XXX00002

Bit symbol	Bit name	Function	R	W
PM20	Specifying wait when accessing SFR registers (Note 2)	0 : 2 waits 1 : 1 wait	○	○
PM21	System clock protective bit (Notes 3,4)	0 : Clock is protected by PRCR register 1 : Clock modification disabled	○	○
PM22	WDT count source protective bit (Notes 3,5)	0 : CPU clock is used for the watchdog timer count source 1 : Ring oscillator clock is used for the watchdog timer count source	○	○
Reserved bit		Must always be set to "0"	○	○
PM24	P85/ $\overline{\text{NMI}}$ configuration bit (Notes 3,6,7)	0: P85 function ($\overline{\text{NMI}}$ disable) 1: $\overline{\text{NMI}}$ function	○	○
Nothing is assigned. Writes must set each bit to "0". Read values are indeterminate.			—	—

Note 1: Set bit 1 of the protect register (address 000A16) to "1" before writing new values to this register.

Note 2: When the system clock is 16Mhz and more, must set to 2 waits.

Note 3: This bit cannot be changed from "1" to "0" in software.

Note 4: Setting PM21 to "1" results in the following:

- BCLK is not halted by WAIT instruction.
- Writing to the following bits has no effect:
CM02, of register CM0
CM05, of register CM0 (main clock is not halted)
CM07, of register CM0 (CPU clock source does not change)
CM10, of register CM1 (stop mode is not entered)
CM20, of register CM2 (oscillation stop, re-oscillation detection function settings do not change)

Note 5: Setting PM22 to "1" results in the following:

- The ring oscillator starts oscillating, and the ring oscillator clock becomes the watchdog timer count source.
- Writing to CM10 disabled (stop mode is not entered).
- Watchdog timer does not stop when in wait mode or hold state.

Note 6: For NMI function, this bit must be set to "1" in first instruction after reset.

Note 7: When this bit is set to "1", the P85 direction register must be "0".

Figure 1.8.4c. Processor mode register 2

Oscillation Stop Detection Function

The oscillation stop detection function detects abnormal stopping of the clock by causes such as opening and shorting of the X_{IN} oscillation circuit. When oscillation stop is detected, either an internal reset or an oscillation stop detection interrupt is generated. The selection depends on the value in the bit 7 of the oscillation stop detection register (address 000C16). When an oscillation stop detection interrupt is generated, the ring oscillator in the microcomputer operates automatically and is used as the system clock in place of the X_{IN} clock. This allows interrupt processing.

The oscillation stop detection function can be enabled/disabled with bit 0 of the oscillation stop detection register. When this bit is set to "1," the function is enabled. After the reset is released, the oscillation stop detection function becomes disabled because the bit value is "0."

Table 1.8.2 gives an specification overview of the oscillation stop detection function, Figure 1.8.5 is a configuration diagram of the oscillation stop detection circuit and Figure 1.8.6 shows the configuration of the oscillation stop detection register.

Table 1.8.2. Specification overview of the oscillation stop detection function

Item	Specification
Oscillation stop detectable clock and frequency bandwidth	$f(X_{IN}) \geq 2 \text{ MHz}$
Enabling condition for oscillation stop detection function	When the oscillation stop detection bit (bit 0 of address 000C16) is set to "1"
Operation at oscillation stop, re-oscillation detection	<ul style="list-style-type: none"> Internal reset occurs (when bit CM27 = "0") Oscillation stop, re-oscillation detection interrupt occurs (when bit CM27 = "1")
Notes on STOP mode	Before setting up the stop mode, write "0" in the oscillation stop detection enable bit to disable the oscillation stop detection function. Write "1" in the bit again after the stop mode is.

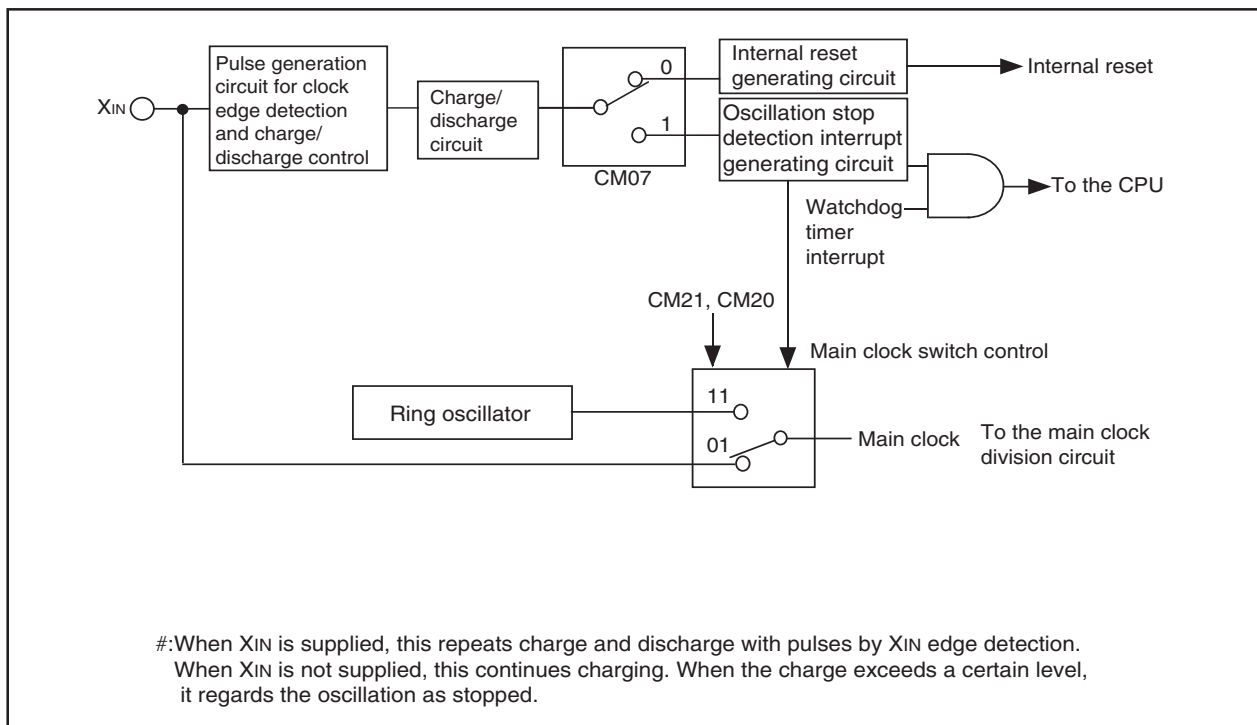

Figure 1.8.5. Oscillation stop detection circuit

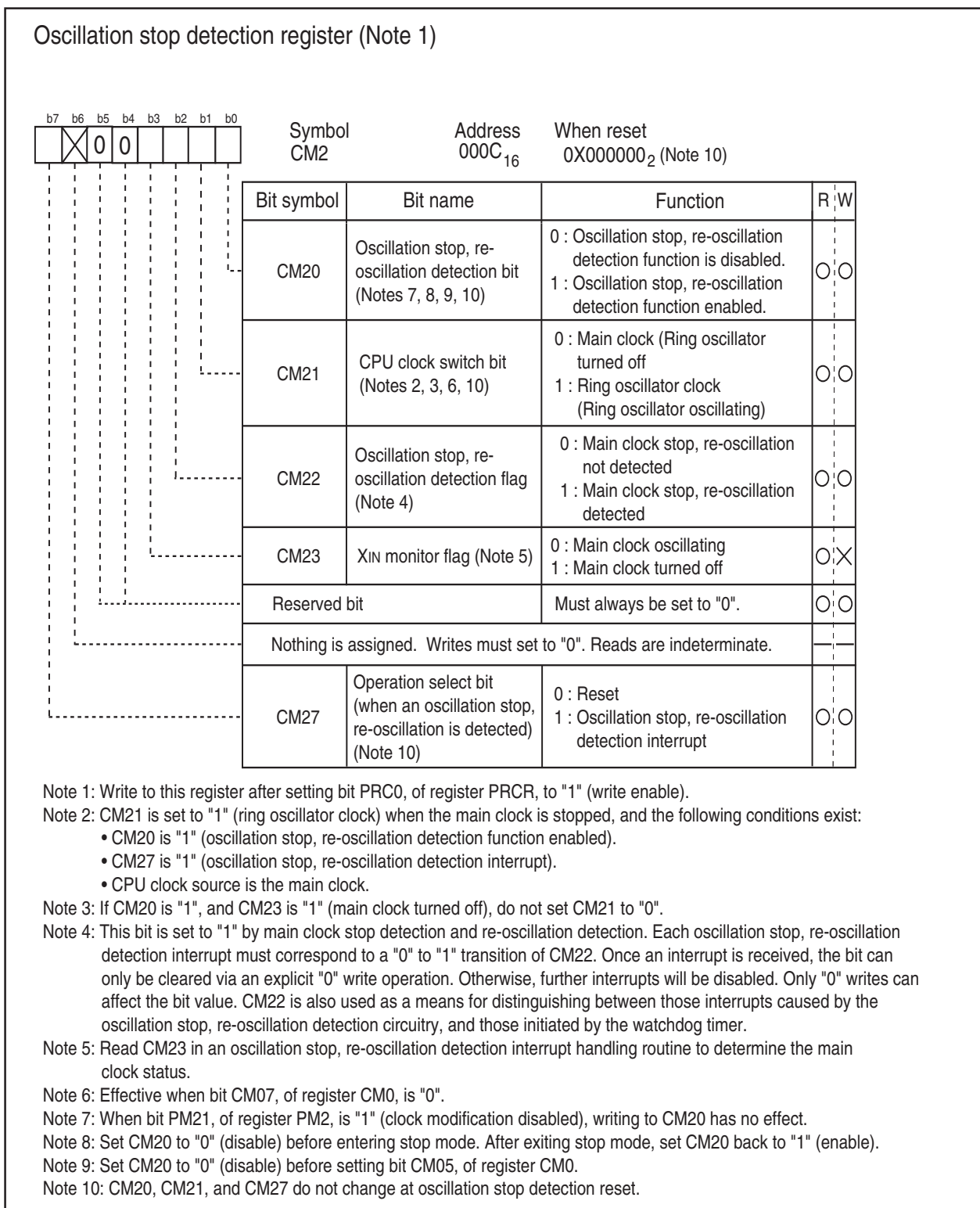

Figure 1.8.6. Oscillation stop detection register

Oscillation stop detection bit (CM20)

You can start the oscillation stop detection by setting this bit to “1”. The detection is not executed when this bit is set to “0” or in reset status. Be sure to set this bit to “0” before setting for the stop-mode. Set this bit again to “1” after release from stop-mode. This is because it is necessary to cancel the oscillation stop detection function due to a certain period of unstable oscillation after release from stop-mode. Set this bit to “0” also before setting the main clock stop bit (bit 5 at 000616) to “1”.

Do not set this bit to “1” if the frequency of XIN is lower than 2 MHz.

Main clock switch bit (CM21)

You can use the ring oscillator as a system clock by setting this bit to “1”. When this bit is “0”, the ring oscillator is not in operation. For more explanation, see the section of the clock generating circuit.

Oscillation stop detection status (CM22)

You can see the status of the oscillation stop detection. When this bit is “1”, an oscillation stop is detected. For usage of this bit, see the explanation on CM27.

Clock monitor bit (CM23)

You can see the operation status of the XIN clock. When this bit is “0”, XIN is operating correctly. You can check the operation status of XIN when an oscillation stop detection interrupt is generated.

Operation select (when an oscillation stop is detected) bit (CM27)

- (1) Operation when internal reset is selected (CM27 is set to “0”).

An internal reset is generated when an abnormal stop of XIN is detected. The microcomputer stops in reset status and does not operate further.

Note: Release from this status is only possible through an external reset. However, in case of a defect XIN clock, further operation cannot be compensated.

All ports are configured to input port (floating) after an internal reset is generated.

- (2) Operation when oscillation stop detection interrupt is selected (CM27 is set to “1”).

An oscillation stop detection interrupt is generated when an abnormal stop of XIN is detected. The ring oscillator starts operation instead of the XIN clock which stopped abnormally. The operation goes further with the supply from the ring oscillator. For the oscillation stop detection interrupt judgement on the interrupt condition is necessary, because this interrupt shares the vector table with watchdog timer interrupt. Use the oscillation stop detection status (CM22) for the judgment. By clearing CM22, the acceptance of oscillation stop detection interrupt resumes. Figure 1.8.7 shows the flow of the judgment.

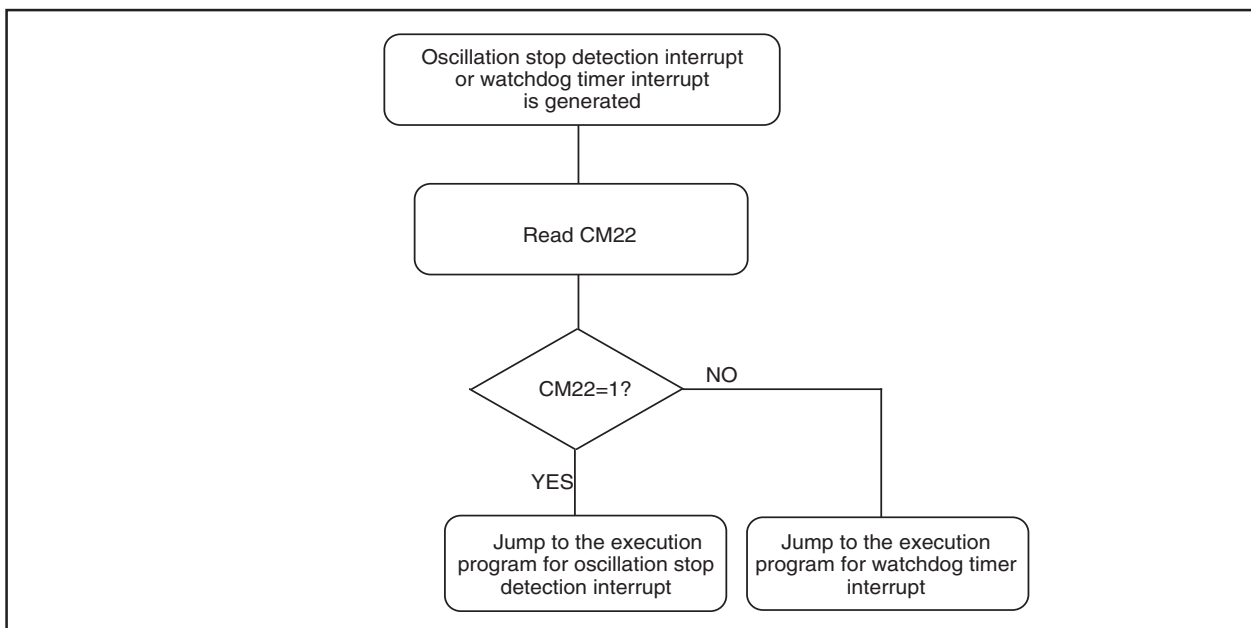

Figure 1.8.7. Flow of the judgment

Stop Mode

Writing “1” to the all-clock stop control bit (bit 0 at address 000716) stops all oscillation and the microcomputer enters stop mode. In stop mode, the content of the internal RAM is retained provided that Vcc remains above 2V.

Because the oscillation, BCLK, f1 to f32, f1SIO2 to f32SIO2, fc, fc32, and fAD stops in stop mode, peripheral functions such as the A-D converter and watchdog timer do not function. However, timer A and timer B operate provided that the event counter mode is set to an external pulse, and UARTi(i = 0 to 2) functions provided an external clock is selected. Port pins retain their status from before stop mode is entered.

Stop mode is cancelled by a hardware reset or an interrupt. If an interrupt is to be used to cancel stop mode, that interrupt must first have been enabled, and the priority level of the interrupts which are not used to cancel must have been changed to 0. If returning by an interrupt, that interrupt routine is executed. If only a hardware reset or an NMI interrupt is used to cancel stop mode, change the priority level of all interrupts to 0, then shift to stop mode.

The main clock division select bit 0 (bit 6 at address 000616) changes to “1” when shifting from high-speed/medium-speed mode to stop mode, shifting to low power dissipation mode and at reset. When shifting from high-speed/medium-speed mode to low-speed mode, the value before high-speed/medium-speed mode is retained.

Wait Mode

When a WAIT instruction is executed, the BCLK stops and the microcomputer enters the wait mode. In this mode, oscillation continues but the BCLK and watchdog timer stop. Writing “1” to the WAIT peripheral function clock stop bit and executing a WAIT instruction stops the clock being supplied to the internal peripheral functions, allowing power dissipation to be reduced. However, peripheral function clock fc32 does not stop so that the peripherals using fc32 do not contribute to the power saving. When the microcomputer is running in low-speed or low power dissipation mode, do not enter WAIT mode with this bit set to “1”. Port pins retain their status from before wait mode is entered.

Wait mode is cancelled by a hardware reset or an interrupt. If an interrupt is used to cancel wait mode, that interrupt must first have been enabled, and the priority level of the interrupts which are not used to cancel must have been changed to 0. If returning by an interrupt, the clock in which the WAIT instruction executed is set to BCLK by the microcomputer, and the action is resumed from the interrupt routine. If only a hardware reset or an NMI interrupt is used to cancel wait mode, change the priority level of all interrupts to 0, then shift to wait mode.

Status Transition of BCLK

Power dissipation can be reduced and low-voltage operation achieved by changing the count source for BCLK. Table 1.8.3 shows the operating modes corresponding to the settings of system clock control registers 0 and 1.

When reset, the device starts in division by 8 mode. The main clock division select bit 0 (bit 6 at address 0006₁₆) and the XIN-XOUT drive capacity select bit (bit 5 at address 0007₁₆) change to “1” when shifting from high-speed/medium-speed mode to stop mode, shifting to low power dissipation mode and at a reset. When shifting from high-speed/medium-speed mode to low-speed mode, the value before high-speed/medium-speed mode is retained. The following shows the operational modes of BCLK.

(1) Division by 2 mode

The main clock is divided by 2 to obtain the BCLK.

(2) Division by 4 mode

The main clock is divided by 4 to obtain the BCLK.

(3) Division by 8 mode

The main clock is divided by 8 to obtain the BCLK. When reset, the device starts operating from this mode. Before the user can go from this mode to no division mode, division by 2 mode, or division by 4 mode, the main clock must be oscillating stably. When going to low-speed or lower power consumption mode, make sure the sub-clock is oscillating stably.

(4) Division by 16 mode

The main clock is divided by 16 to obtain the BCLK.

(5) No-division mode

The main clock is divided by 1 to obtain the BCLK.

(6) Low-speed mode

fc is used as the BCLK. Note that oscillation of both the main and sub-clocks must have stabilized before transferring from this mode to another or vice versa. At least 2 to 3 seconds are required after the sub-clock starts. Therefore, the program must be written to wait until this clock has stabilized immediately after powering up and after stop mode is cancelled.

(7) Low power dissipation mode

fc is the BCLK and the main clock is stopped.

Table 1.8.3. Operating modes dictated by settings of system clock control registers 0, 1, and 2

Modes		CM2 register	CM1 register		CM0 register			
		CM21	CM11	CM17, CM16	CM07	CM06	CM05	CM04
High-speed mode		0	0	002	0	0	0	—
Midium-speed mode	divided by 2	0	0	012	0	0	0	—
	divided by 4	0	0	102	0	0	0	—
	divided by 8	0	0	—	0	1	0	—
	divided by 16	0	0	112	0	0	0	—
Low-speed mode		—	—	—	1	—	0	1
Low power dissipation mode		—	—	—	1	1(Note 1)	1(Note 1)	1
Ring oscillator mode	divided by 1	1	—	0 02	0	0	0	—
	divided by 2	1	—	0 12	0	0	0	—
	divided by 4	1	—	1 02	0	0	0	—
	divided by 8	1	—	0 —	—	1	0	—
	divided by 16	1	—	1 12	0	0	0	—
Ring oscillator low power dissipation mode		1	—	— (Note 2)	0	(Note 2)	1	—

Note 1: When set the CM05 bit to "1" (main clock turned off), CM06 bit become "1" (divided by 8 mode).

Note 2: The divide-by-n value can be selected the same way as in ring oscillator mode.

Power control

The following is a description of the three available power control modes:

Modes

Power control is available in three modes.

(a) Normal operation mode

- **High-speed mode**

Divide-by-1 frequency of the main clock becomes the BCLK. The CPU operates with the BCLK. Each peripheral function operates according to its assigned clock.

- **Medium-speed mode**

Divide-by-2, divide-by-4, divide-by-8, or divide-by-16 frequency of the main clock becomes the BCLK. The CPU operates with the BCLK. Each peripheral function operates according to its assigned clock.

- **Low-speed mode**

fc becomes the BCLK. The CPU operates according to the fc clock. The fc clock is supplied by the subclock. Each peripheral function operates according to its assigned clock.

- **Low power dissipation mode**

The main clock operating in low-speed mode is stopped. The CPU operates according to the fc clock. The fc clock is supplied by the subclock. The only peripheral functions that operate are those with the subclock selected as the count source.

- **Ring oscillator mode**

The ring oscillator clock divided by 1 (undivided), 2, 4, 8, or 16 provides BCLK. The ring oscillator clock is also the clock source for the peripheral function clocks. If the sub-clock is on, fC32 can be used as the count source for timers A and B.

- **Ring oscillator low power dissipation mode**

The main clock is turned off after being placed in ring oscillator mode. The CPU clock can be selected as in the ring oscillator mode. The ring oscillator clock is the clock source for the peripheral function clocks. If the sub-clock is on, fC32 can be used as the count source for timers A and B. When the operation mode is returned to the high and medium speed modes, set the CM06 bit to "1" (divided by 8 mode).

(b) Wait mode

The CPU operation is stopped. The oscillators do not stop.

(c) Stop mode

All oscillators stop. The CPU and all built-in peripheral functions stop. This mode, among the three modes listed here, is the most effective in decreasing power consumption.

Table 1.8.4. Oscillation state in each mode

	XIN	XCIN	Ring
Medium-speed mode (divide-by-8 frequency after reset released)	BCLK	OFF	OFF
High/medium-speed	BCLK	ON/OFF	ON/OFF
Low-speed mode	ON	BCLK	OFF
Low power dissipation mode	OFF	BCLK	OFF
Ring oscillator mode	ON/OFF	ON/OFF	BCLK
Ring oscillator low power dissipation mode	OFF	ON/OFF	BCLK

Figure 1.8.8 is the state transition diagram of the above modes.

Transition of stop mode, wait mode

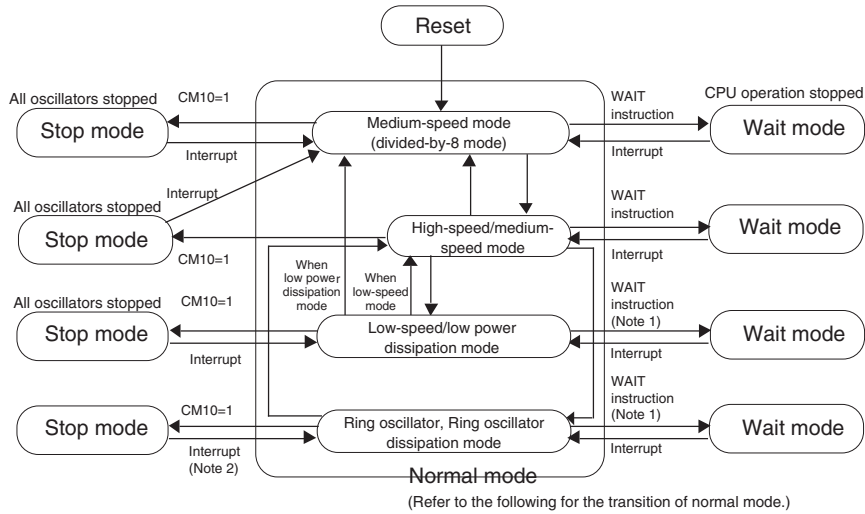

Transition of normal mode

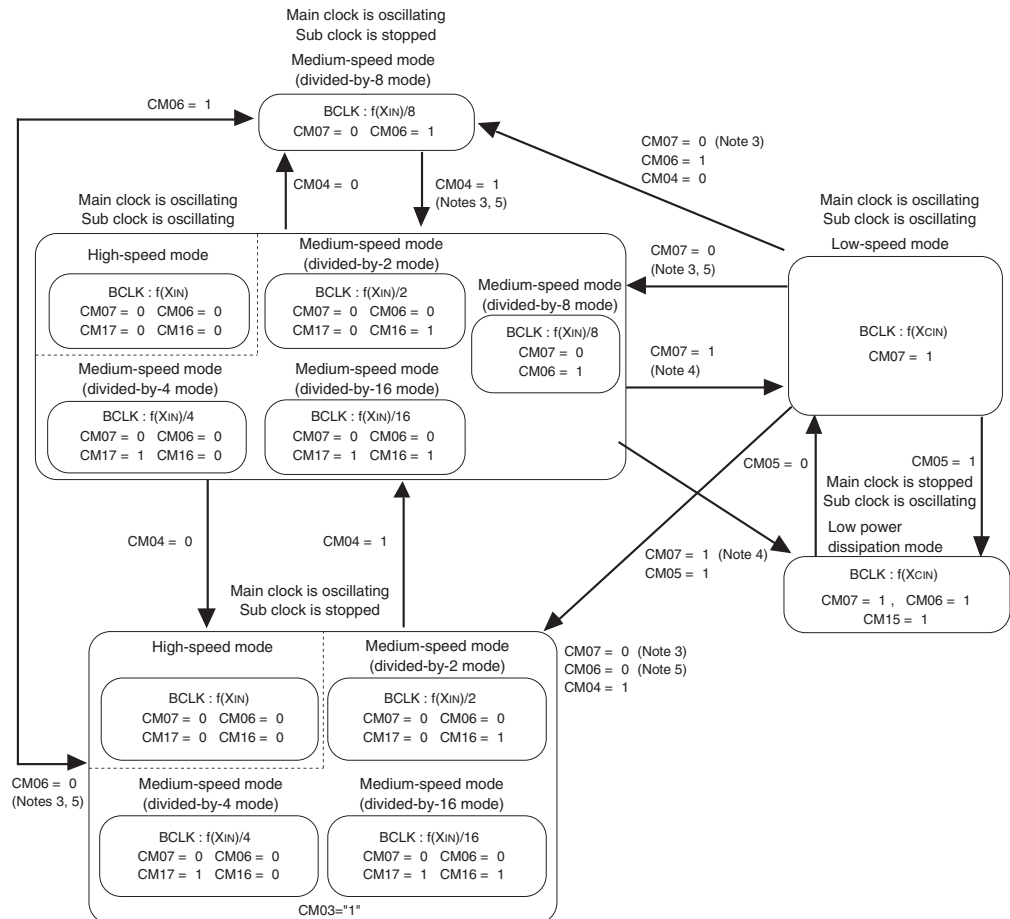

- Note 1: When bit PM21 = "0" (system clock protective function unused).
- Note 2: The ring oscillator clock divided by 8 provides BCLK.
- Note 3: Switch clock after oscillation of main clock is sufficiently stable.
- Note 4: Switch clock after oscillation of sub clock is sufficiently stable.
- Note 5: Change CM06 after changing CM17 and CM16.

Figure 1.8.8. State transition diagram of power control mode

Protection

The protection function is provided so that the values in important registers cannot be changed in the event that the program runs out of control. Figure 1.8.9 shows the protect register. The values in the processor mode register 0 (address 0004₁₆), processor mode register 1 (address 0005₁₆), system clock control register 0 (address 0006₁₆), system clock control register 1 (address 0007₁₆), oscillation stop detection register (address 000C₁₆), processor mode register 2 (001E₁₆), peripheral clock select register (address 025E₁₆), timer B2 special mode register (039E₁₆), port P9 direction register (address 03F3₁₆), three-phase PWM control register 0 (address 0348₁₆) and three-phase PWM control register 1 (address 0349₁₆) can only be changed when the respective bit in the protect register is set to "1". Therefore, important outputs can be allocated to port P9.

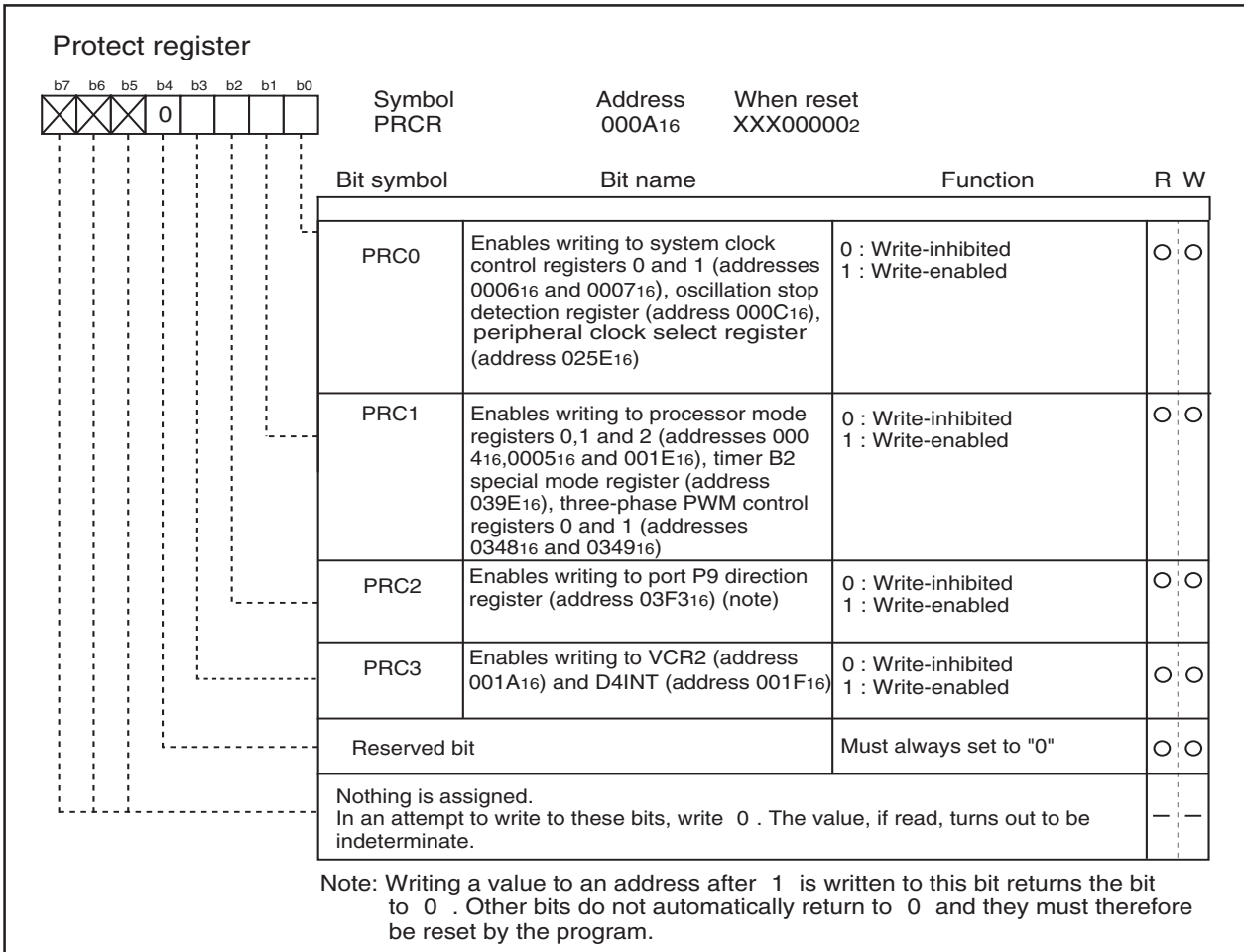

Figure 1.8.9. Protect register

Interrupts

Type of Interrupts

Figure 1.9.1 lists the types of interrupts.

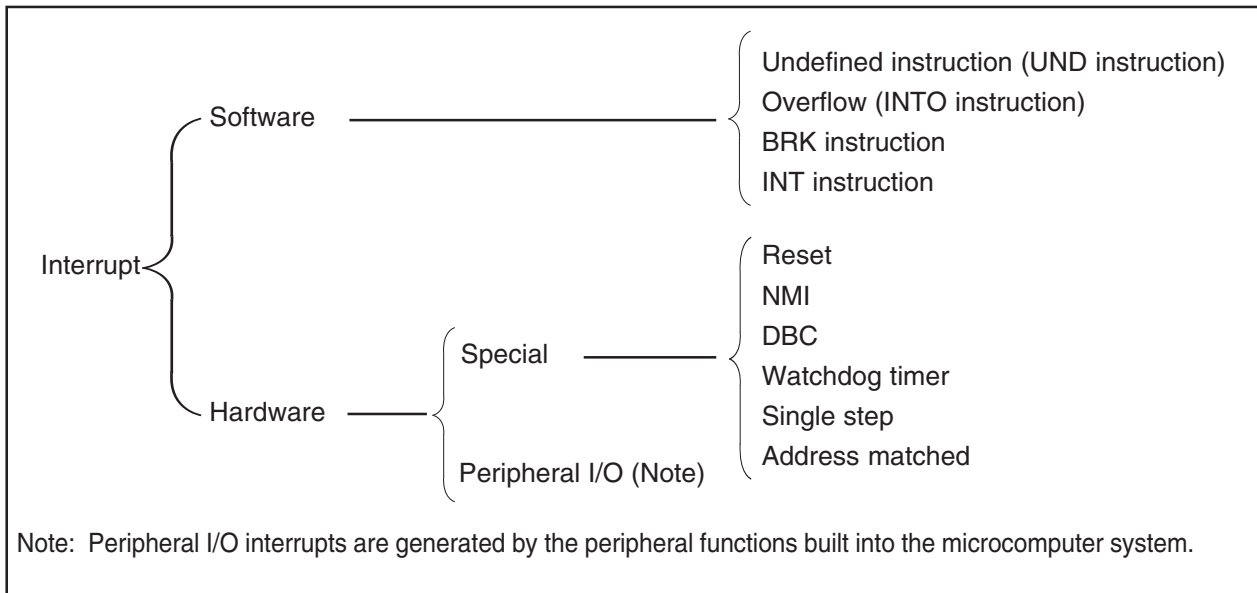

Figure 1.9.1. Classification of interrupts

- Maskable interrupt : An interrupt which can be enabled (disabled) by the interrupt enable flag (I flag) or whose interrupt priority **can be changed** by priority level.
- Non-maskable interrupt : An interrupt which cannot be enabled (disabled) by the interrupt enable flag (I flag) or whose interrupt priority **cannot be changed** by priority level.

Software Interrupts

A software interrupt occurs when executing certain instructions. Software interrupts are non-maskable interrupts.

- **Undefined instruction interrupt**

An undefined instruction interrupt occurs when executing the UND instruction.

- **Overflow interrupt**

An overflow interrupt occurs when executing the INTO instruction with the overflow flag (O flag) set to "1". The following are arithmetic instructions changes O flag:

ABS, ADC, ADCF, ADD, CMP, DIV, DIVU, DIVX, NEG, RMPA, SBB, SHA, SUB

- **BRK interrupt**

A BRK interrupt occurs when executing the BRK instruction.

- **INT interrupt**

An INT interrupt occurs when specifying one of software interrupt numbers 0 through 63 and executing the INT instruction. Software interrupt numbers 0 through 31 are assigned to peripheral I/O interrupts, so executing the INT instruction allows executing the same interrupt routine that a peripheral I/O interrupt does.

The stack pointer (SP) used for the INT interrupt is dependent on the software interrupt number involved.

For software interrupt numbers 0 through 31, the microcomputer saves the stack pointer assignment flag (U flag) when it accepts an interrupt request. The U flag is changed to "0" and the interrupt stack pointer (ISP) is selected, and then, the interrupt sequence is executed. When returning from the interrupt routine, the U flag is returned to the state it was before the interrupt request was accepted. For software numbers 32 through 63, the U flag is not changed, and so the stack pointer is not affected.

Hardware Interrupts

Hardware interrupts are classified into two types — special interrupts and peripheral I/O interrupts.

(1) Special interrupts

Special interrupts are non-maskable interrupts.

- **Reset**

Reset occurs if an “L” is input to the RESET pin.

- **NMI interrupt**

If enabled, an NMI interrupt occurs if an “L” is input to the NMI pin.

- **DBC interrupt**

This interrupt is exclusively for the debugger, do not use it in other circumstances.

- **Watchdog timer interrupt**

Generated by the watchdog timer. Write to the watchdog timer start register after the watchdog timer interrupt occurs (initialize watchdog timer).

- **Single-step interrupt**

This interrupt is exclusively for the debugger, do not use it in other circumstances. With the debug flag (D flag) set to “1”, a single-step interrupt occurs after one instruction is executed.

- **Address match interrupt**

An address match interrupt occurs immediately before the instruction held in the address indicated by the address match interrupt register is executed with the address match interrupt enable bit set to “1”. If an address other than the first address of the instruction in the address match interrupt register is set, no address match interrupt occurs.

(2) Peripheral I/O interrupts

A peripheral I/O interrupt is generated by one of built-in peripheral functions. Built-in peripheral functions are dependent on classes of products, so the interrupt factors too are dependent on classes of products. The interrupt vector table is the same as the one for software interrupt numbers 0 through 31 the INT instruction uses. Peripheral I/O interrupts are maskable interrupts.

- **Bus collision detection interrupt**

This is an interrupt that UART2 generates.

- **DMA0 interrupt, DMA1 interrupt**

These are interrupts that DMA generates.

- **Key-input interrupt**

A key-input interrupt occurs if an “L” is input to the KI pin.

- **A-D conversion interrupt**

This is an interrupt that the A-D converter generates.

- **UART0, UART1, and UART2/NACK2 transmission interrupt**

These are interrupts that the serial I/O transmission generates.

- **UART0, UART1, and UART2/ACK2 reception interrupt**

These are interrupts that the serial I/O reception generates.

- **Timer A0 interrupt through timer A4 interrupt**

These are interrupts that timer A generates

- **Timer B0 interrupt through timer B2 interrupt**

These are interrupts that timer B generates.

- **INT0, INT1, INT3 through INT5 interrupt**

An INT interrupt occurs if either a rising edge or a falling edge or a both edge is input to the INT pin.

Interrupts and Interrupt Vector Tables

If an interrupt request is accepted, a program branches to the interrupt routine set in the interrupt vector table. The first address of the interrupt routine is stored in the corresponding vector. Figure 1.9.2 shows the format for specifying the address.

Two types of interrupt vector tables are available — fixed vector table in which addresses are fixed and variable vector table in which addresses can be varied by the setting.

	MSB	LSB
Vector address + 0	Low address	
Vector address + 1	Mid address	
Vector address + 2	0 0 0 0	High address
Vector address + 3	0 0 0 0	0 0 0 0

Figure 1.9.2. Format for specifying interrupt vector addresses

• Fixed vector table

The fixed vector table is a table in which addresses are fixed. The vector tables are located in an address range extending from FFFDC₁₆ to FFFFF₁₆. A vector consists of four bytes. Set the first address of interrupt routine in the corresponding vector. Table 1.9.1 shows the interrupts assigned to the fixed vector table and the vector addresses.

Table 1.9.1. Interrupts assigned to the fixed vector tables and addresses of vector tables

Interrupt source	Vector table addresses Address (L) to address (H)	Remarks
Undefined instruction	FFFD ₁₆ C to FFFD ₁₆ F	Interrupt on UND instruction
Overflow	FFFE ₁₆ 0 to FFFE ₁₆ 3	Interrupt on INTO instruction
BRK instruction	FFFE ₁₆ 4 to FFFE ₁₆ 7	If the vector contains FF ₁₆ , program execution starts from the address shown by the vector in the variable vector table.
Address match	FFFE ₁₆ 8 to FFFE ₁₆ B	There is an address-matching interrupt enable bit.
Single step (Note)	FFFE ₁₆ C to FFFE ₁₆ F	Do not use.
Watchdog timer, Oscillation stop and re-oscillation detection, VDET4 detection	FFFF ₁₆ 0 to FFFF ₁₆ 3	
DBC (Note)	FFFF ₁₆ 4 to FFFF ₁₆ 7	Do not use.
NMI	FFFF ₁₆ 8 to FFFF ₁₆ B	External interrupt by input to NMI pin.
Reset	FFFF ₁₆ C to FFFF ₁₆ F	

Note: Interrupts used for debugging purposes only.

• Variable vector tables

The addresses in the variable vector table can be modified by user's settings. The first address of the variable vector table is specified by the user using the interrupt table register (INTB). The subsequent 256-byte addresses becomes the area for the variable vector tables. A vector consists of four bytes. Set the first address of the interrupt routine in the corresponding vector. Table 1.9.2 shows the interrupts assigned to the variable vector table and the vector addresses.

Table 1.9.2. Interrupts assigned to the variable vector tables and addresses of vector tables

Software interrupt number	Vector table address Address (L) to address (H)	Interrupt source	Remarks
Software interrupt number 0	+0 to +3 (Note 1)	BRK instruction	Cannot be masked I flag
Software interrupt number 4	+16 to +19 (Note 1)	$\overline{\text{INT3}}$	
Software interrupt number 5	+20 to +23 (Note 1)	Reserved	
Software interrupt number 6	+24 to +27 (Note 1)	Reserved	
Software interrupt number 7	+28 to +31 (Note 1)	Reserved	
Software interrupt number 8	+32 to +35 (Note 1)	$\overline{\text{INT5}}$	
Software interrupt number 9	+36 to +39 (Note 1)	$\overline{\text{INT4}}$	
Software interrupt number 10	+40 to +43 (Note 1)	UART 2 bus collision detection	
Software interrupt number 11	+44 to +47 (Note 1)	DMA0	
Software interrupt number 12	+48 to +51 (Note 1)	DMA1	
Software interrupt number 13	+52 to +55 (Note 1)	Key input interrupt	
Software interrupt number 14	+56 to +59 (Note 1)	A-D	
Software interrupt number 15	+60 to +63 (Note 1)	UART2 transmit/NACK2 (Note 2)	
Software interrupt number 16	+64 to +67 (Note 1)	UART2 receive/ACK2 (Note 2)	
Software interrupt number 17	+68 to +71 (Note 1)	UART0 transmit	
Software interrupt number 18	+72 to +75 (Note 1)	UART0 receive	
Software interrupt number 19	+76 to +79 (Note 1)	UART1 transmit	
Software interrupt number 20	+80 to +83 (Note 1)	UART1 receive	
Software interrupt number 21	+84 to +87 (Note 1)	Timer A0	
Software interrupt number 22	+88 to +91 (Note 1)	Timer A1	
Software interrupt number 23	+92 to +95 (Note 1)	Timer A2	
Software interrupt number 24	+96 to +99 (Note 1)	Timer A3	
Software interrupt number 25	+100 to +103 (Note 1)	Timer A4	
Software interrupt number 26	+104 to +107 (Note 1)	Timer B0	
Software interrupt number 27	+108 to +111 (Note 1)	Timer B1	
Software interrupt number 28	+112 to +115 (Note 1)	Timer B2	
Software interrupt number 29	+116 to +119 (Note 1)	$\overline{\text{INT0}}$	
Software interrupt number 30	+120 to +123 (Note 1)	$\overline{\text{INT1}}$	
Software interrupt number 31	+124 to +127 (Note 1)	Reserved	
Software interrupt number 32 to Software interrupt number 63	+128 to +131 (Note 1) to +252 to +255 (Note 1)	Software interrupt	Cannot be masked I flag

Note 1: Address relative to address specified in interrupt table register (INTB).

Note 2: When IIC mode is selected, NACK and ACK interrupts are selected.

Interrupt Control

This section describes how to enable or disable maskable interrupts and how to set the priority to be accepted. The discussion here does not apply to non-maskable interrupts.

Maskable interrupts are enabled or disabled using the interrupt enable flag (I flag), the interrupt priority level selection bit, and the processor interrupt priority level (IPL). Whether an interrupt request is present or absent is indicated by the interrupt request bit. The interrupt request bit and the interrupt priority level selection bit are located in the interrupt control register of each interrupt. Also, the interrupt enable flag (I flag) and the IPL are located in the flag register (FLG).

Figure 1.9.3 shows the configuration and memory map of the interrupt control registers.

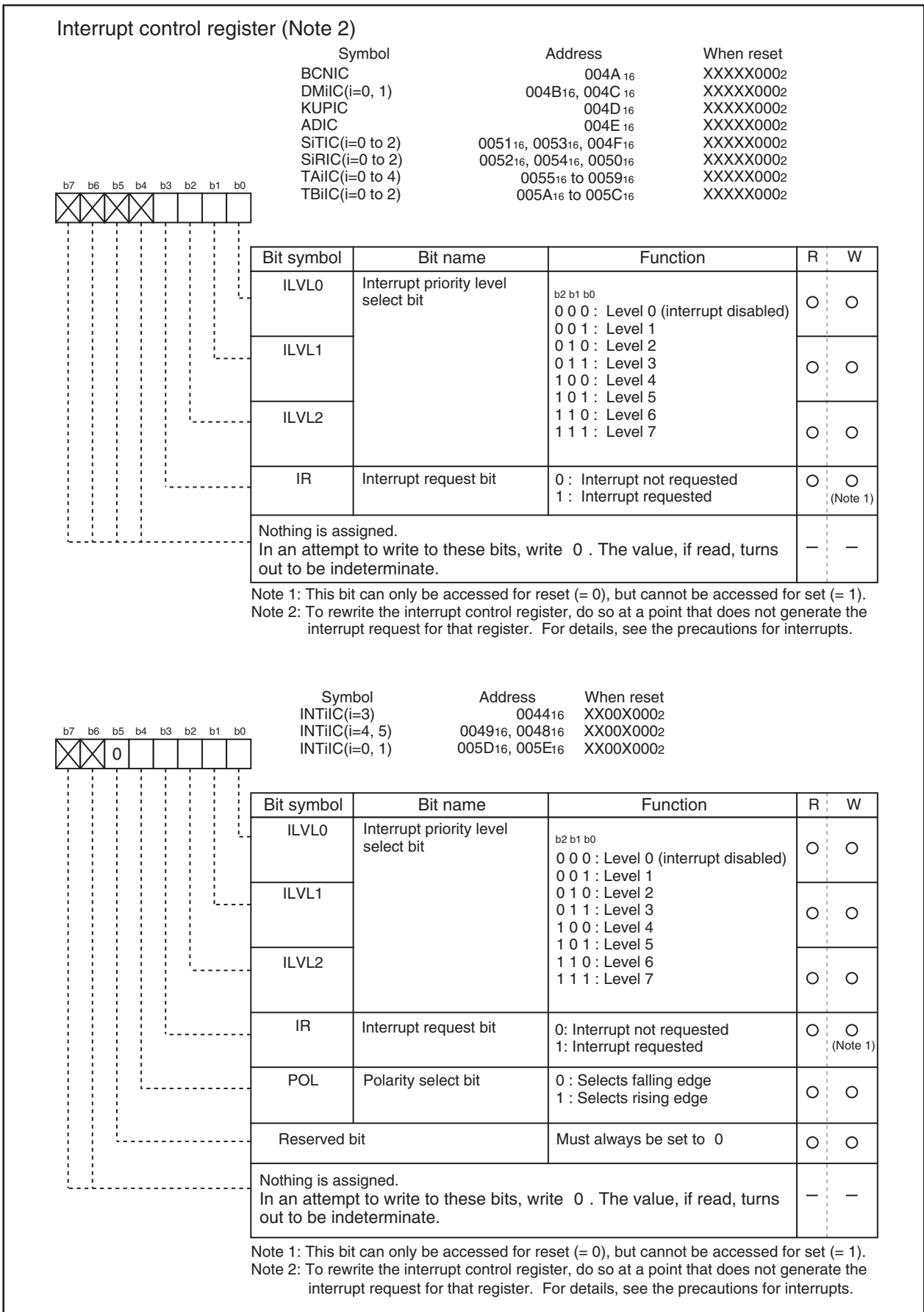

Figure 1.9.3. Interrupt control registers

Interrupt Enable Flag (I flag)

The interrupt enable flag (I flag) controls the enabling and disabling of maskable interrupts. Setting this flag to “1” enables all maskable interrupts while setting it to “0” disables all maskable interrupts. This flag is set to “0” after reset.

Interrupt Request Bit

The interrupt request bit is set to “1” by hardware when an interrupt is requested. After the interrupt is accepted and jumps to the corresponding interrupt vector, the request bit is set to “0” by hardware. The interrupt request bit can also be set to “0” by software. (Do not set this bit to “1”).

Interrupt Priority Level Select Bit and Processor Interrupt Priority Level (IPL)

Set the interrupt priority level using the interrupt priority level select bit, which is one of the component bits of the interrupt control register. When an interrupt request occurs, the interrupt priority level is compared with the IPL. The interrupt is enabled only when the priority level of the interrupt is higher than the IPL. Therefore, setting the interrupt priority level to “0” disables the interrupt.

Table 1.9.3 shows the settings of interrupt priority levels and Table 1.9.4 shows the interrupt levels enabled, according to the contents of the IPL.

The following are conditions under which an interrupt is accepted:

- interrupt enable flag (I flag) = “1”
- interrupt request bit = “1”
- interrupt priority level > IPL

The interrupt enable flag (I flag), the interrupt request bit, the interrupt priority select bit, and the IPL are independent, and so, not affected by one another.

Table 1.9.3. Settings of interrupt priority levels

Interrupt priority level select bit	Interrupt priority level	Priority order
b2 b1 b0 0 0 0	Level 0 (interrupt disabled)	_____
0 0 1	Level 1	Low ↓ High
0 1 0	Level 2	
0 1 1	Level 3	
1 0 0	Level 4	
1 0 1	Level 5	
1 1 0	Level 6	
1 1 1	Level 7	

Table 1.9.4. Interrupt levels enabled according to the contents of the IPL

IPL	Enabled interrupt priority levels
IPL ₂ IPL ₁ IPL ₀ 0 0 0	Interrupt levels 1 and above are enabled
0 0 1	Interrupt levels 2 and above are enabled
0 1 0	Interrupt levels 3 and above are enabled
0 1 1	Interrupt levels 4 and above are enabled
1 0 0	Interrupt levels 5 and above are enabled
1 0 1	Interrupt levels 6 and above are enabled
1 1 0	Interrupt levels 7 and above are enabled
1 1 1	All maskable interrupts are disabled

Rewrite the interrupt control register

To rewrite the interrupt control register, do so at a point that does not generate the interrupt request for that register. If there is possibility of the interrupt request occur, rewrite the interrupt control register after the interrupt is disabled. The program examples are described as follow:

Example 1:

```
INT_SWITCH1:
  FCLR  I           ; Disable interrupts.
  AND.B #00h, 0055h ; Clear TA0IC int. priority level and int. request bit.
  NOP                    ; Four NOP instructions are required when using HOLD function.
  NOP
  FSET  I           ; Enable interrupts.
```

Example 2:

```
INT_SWITCH2:
  FCLR  I           ; Disable interrupts.
  AND.B #00h, 0055h ; Clear TA0IC int. priority level and int. request bit.
  MOV.W MEM, R0     ; Dummy read.
  FSET  I           ; Enable interrupts.
```

Example 3:

```
INT_SWITCH3:
  PUSHC FLG        ; Push Flag register onto stack
  FCLR  I           ; Disable interrupts.
  AND.B #00h, 0055h ; Clear TA0IC int. priority level and int. request bit.
  POPC  FLG        ; Enable interrupts.
```

The reason why two NOP instructions (four when using the HOLD function) or dummy read are inserted before FSET I in Examples 1 and 2 is to prevent the interrupt enable flag I from being set before the interrupt control register is rewritten due to effects of the instruction queue.

When changing an interrupt control register at a point where the interrupt is disabled, please read the following precautions on instructions used before changing the register.

(1) Changing a non-interrupt request bit (interrupt priority level)

If an interrupt request for an interrupt control register is generated during an instruction to rewrite the register is being executed, it is possible that the interrupt request bit is overwritten (reset to "0") and consequently the interrupt is ignored. This will depend on the instruction used. If this creates problems, use the instructions below to change the register.

Instructions : AND, OR, BCLR, BSET

(2) Changing the interrupt request bit

When attempting to clear the interrupt request bit of an interrupt control register, the interrupt request bit is not cleared sometimes. This will depend on the instruction used. If this creates problems, use the instructions below to change the register.

Instructions : MOV

Interrupt Sequence

This section describes an interrupt sequence — what are performed over a period from the time an interrupt is accepted until the time the interrupt routine is executed .

If an interrupt occurs during execution of an instruction, the processor determines its priority when the execution of the instruction is completed, and transfers control to the interrupt sequence from the next cycle. If an interrupt occurs during execution of either the SMOVB, SMOVF, SSTR or RMPA instruction, the processor temporarily suspends the instruction being executed, and transfers control to the interrupt sequence.

In the interrupt sequence, the processor operates in the following sequence:

- (1) CPU gets the interrupt information (the interrupt number and interrupt request level) by reading address 00000₁₆. After this, the corresponding interrupt request bit becomes “0”.
- (2) Saves the content of the flag register (FLG) as it was immediately before the start of interrupt sequence in the temporary register (Note) within the CPU.
- (3) Sets the interrupt enable flag (I flag), the debug flag (D flag), and the stack pointer select flag (U flag) to “0” (the U flag, however does not change if the INT instruction, in software interrupt numbers 32 through 63, is executed)
- (4) Saves the content of the temporary register (Note) within the CPU in the stack area.
- (5) Saves the content of the program counter (PC) in the stack area.
- (6) Sets the interrupt priority level of the accepted instruction in the IPL.

After the interrupt sequence is completed, the processor resumes executing instructions from the first address of the interrupt routine.

Note: This register cannot be utilized by the user.

Interrupt Response Time

'Interrupt response time' is the period between the time an interrupt occurs and the time the first instruction within the interrupt routine has been executed. This time comprises the period from the occurrence of an interrupt to the completion of the instruction under execution at that moment (a) and the time required for executing the interrupt sequence (b). Figure 1.9.4 shows the interrupt response time.

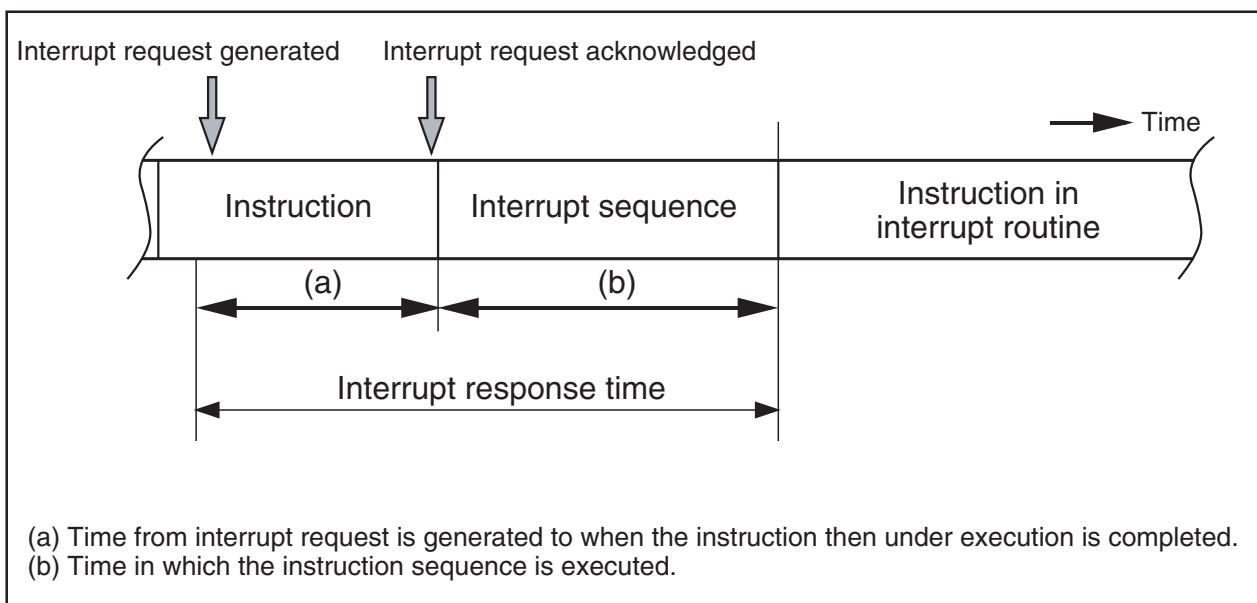

Figure 1.9.4. Interrupt response time

Time (a) is dependent on the instruction under execution. Thirty cycles is the maximum required for the DIVX instruction (without wait).

Time (b) is as shown in Table 1.9.5.

Table 1.9.5. Time required for executing the interrupt sequence

Interrupt vector address	Stack pointer (SP) value	6-Bit bus, without wait	8-Bit bus, without wait
Even	Even	18 cycles (Note 1)	20 cycles (Note 1)
Even	Odd	19 cycles (Note 1)	20 cycles (Note 1)
Odd (Note 2)	Even	19 cycles (Note 1)	20 cycles (Note 1)
Odd (Note 2)	Odd	20 cycles (Note 1)	20 cycles (Note 1)

Note 1: Add 2 cycles in the case of a DBC interrupt; add 1 cycle in the case either of an address match interrupt or of a single-step interrupt.

Note 2: Locate an interrupt vector address in an even address, if possible.

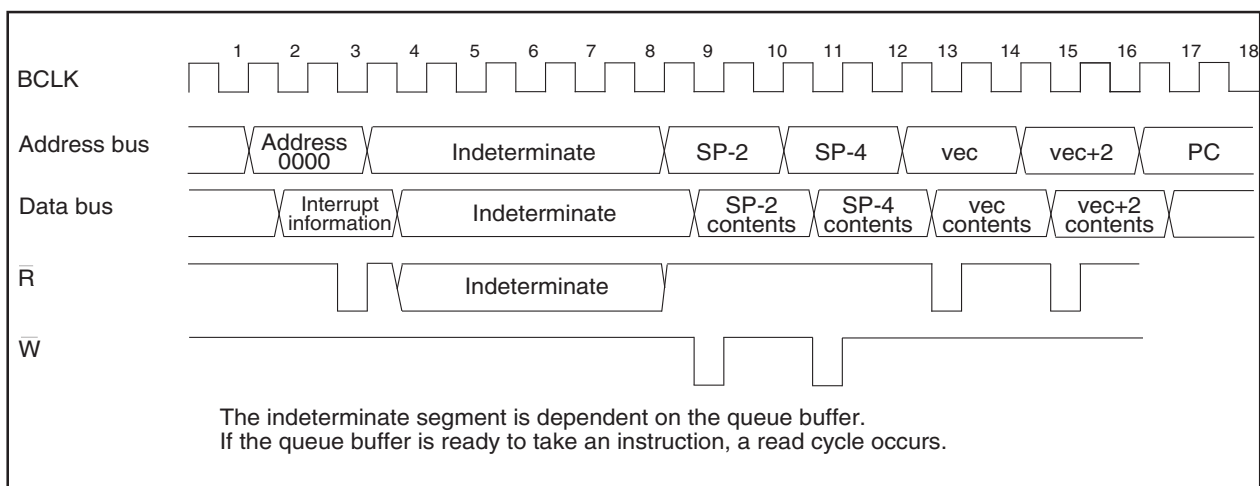

Figure 1.9.5. Time required for executing the interrupt sequence

Variation of IPL when Interrupt Request is Accepted

When a maskable interrupt request is accepted, the interrupt priority level of the accepted interrupt is set in the IPL.

When a software interrupt or special interrupt request is accepted, one of the interrupt priority levels listed in Table 1.9.6 is set in the IPL. Shown in Table 1.9.6 are the IPL values of software and special interrupts when they are accepted.

Table 1.9.6. Relationship between interrupts without interrupt priority levels and IPL

Interrupt sources without priority levels	Level that is set to IPL
Watchdog timer, $\overline{\text{NMI}}$, Oscillation stop and re-oscillation detection, $\overline{\text{VDET4}}$ detection	7
Software, address match, $\overline{\text{DBC}}$, single-step	Not changed

Saving Registers

In the interrupt sequence, only the contents of the flag register (FLG) and that of the program counter (PC) are saved in the stack area.

First, the processor saves the four higher-order bits of the program counter, and 4 upper-order bits and 8 lower-order bits of the FLG register, 16 bits in total, in the stack area, then saves 16 lower-order bits of the program counter. Figure 1.9.6 shows the state of the stack as it was before the acceptance of the interrupt request, and the state the stack after the acceptance of the interrupt request.

To save other necessary registers, use the PUSHM instruction to save these registers except the stack pointer (SP) at the beginning of the interrupt routine.

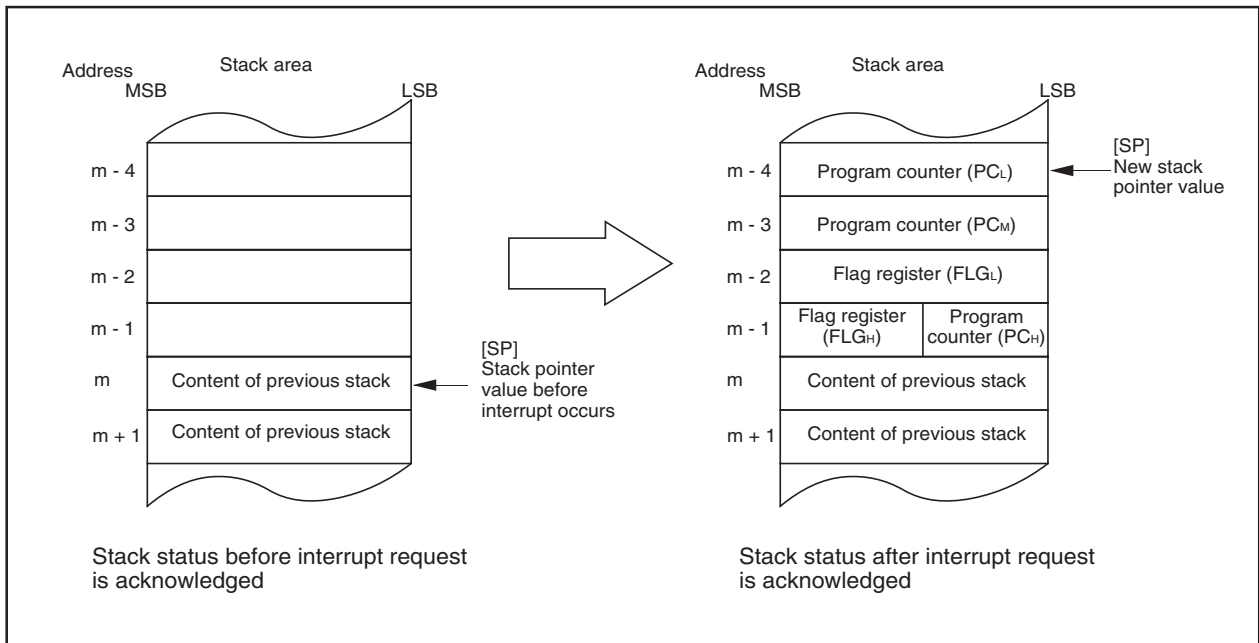

Figure 1.9.6. State of stack before and after acceptance of interrupt request

The operation of saving registers carried out in the interrupt sequence is dependent on whether the content of the stack pointer (Note) , at the time of acceptance of an interrupt request, is even or odd. If the content of the stack pointer (Note) is even, the content of the flag register (FLG) and the content of the program counter (PC) are saved, 16 bits at a time. If odd, their contents are saved in two steps, 8 bits at a time. Figure 1.9.7 shows the operation of the saving registers.

Note: When any INT instruction in software numbers 32 to 63 has been executed, this is the stack pointer indicated by the U flag. Otherwise, it is the interrupt stack pointer (ISP).

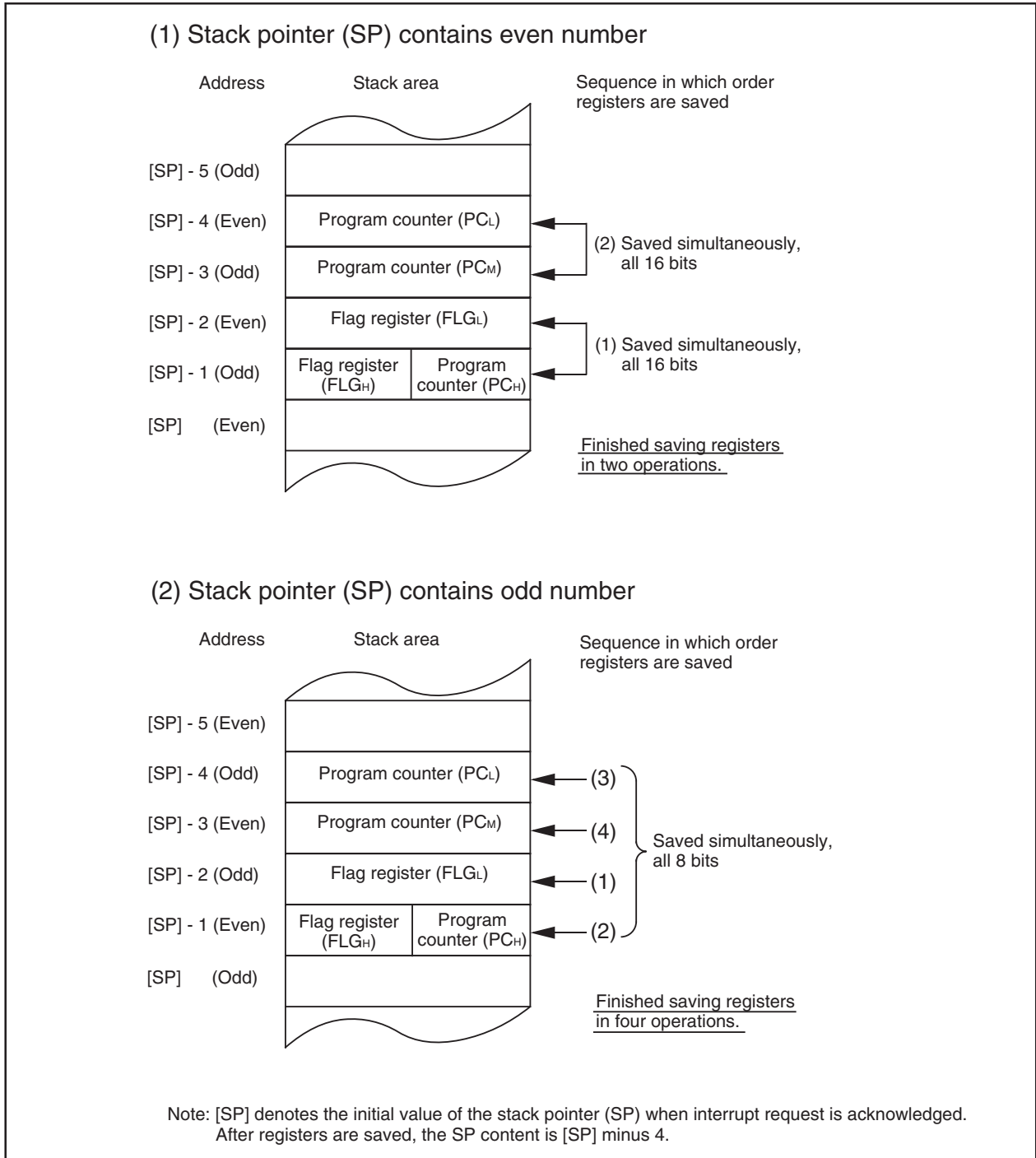

Figure 1.9.7. Operation of saving registers

Returning from an Interrupt Routine

Executing a REIT instruction at the end of an interrupt routine returns the contents of the flag register (FLG) as it was immediately before the start of interrupt sequence and the contents of the program counter (PC), both of which have been saved in the stack area. Then control returns to the program that was being executed before the acceptance of the interrupt request, so that the suspended process resumes.

To return the other registers saved by software within the interrupt routine, use the POPM or similar instruction before executing the REIT instruction.

Interrupt Priority

If there are two or more interrupt requests generated at the same time, the interrupt assigned with a higher priority is accepted.

Assign an arbitrary priority to maskable interrupts (peripheral I/O interrupts) using the interrupt priority level select bit. If the same interrupt priority level is assigned, however, the interrupt assigned with a higher hardware priority is accepted.

Priorities for the special interrupts, such as reset (dealt with as an interrupt assigned the highest priority), watchdog timer interrupt, etc. are controlled by hardware.

Figure 1.9.8 shows the priorities of hardware interrupts.

Software interrupts are not affected by the interrupt priority. If an instruction is executed, control branches invariably to the interrupt routine.

Reset > NMI > DBC > Watchdog timer > Peripheral I/O > Single step > Address match

Figure 1.9.8. Hardware interrupts priorities

Interrupt resolution circuit

When two or more interrupts are generated simultaneously, the circuit in Figure 1.9.9 selects the interrupt based on the priority level shown.

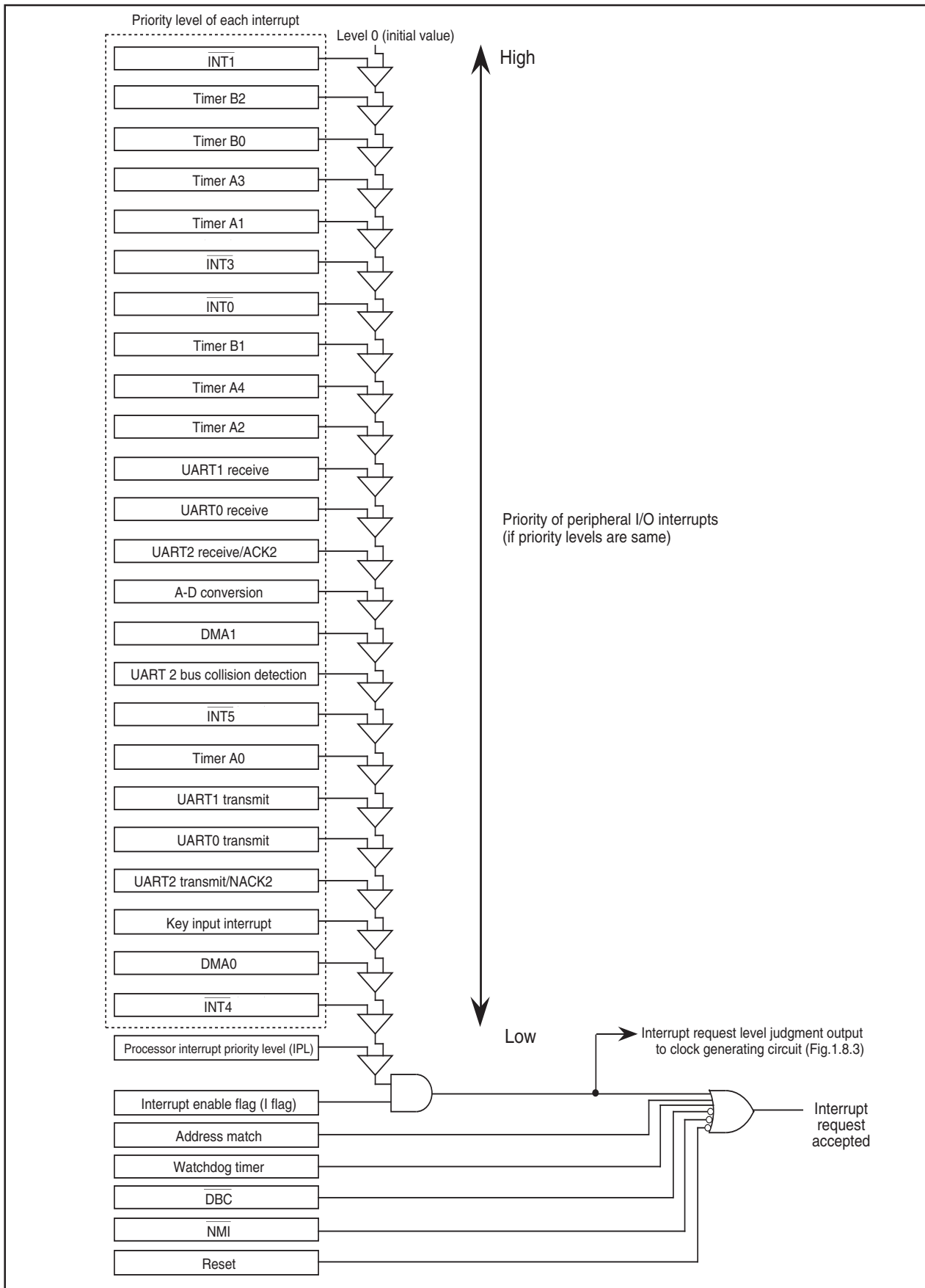

Figure 1.9.9. Maskable interrupts priorities (peripheral I/O interrupts)

INT Interrupt

INT0, INT1, INT3 to INT5 are triggered by the edges of external inputs. The edge polarity of the interrupt is selected using the polarity select bit in the interrupt control registers, 0044₁₆, 0048₁₆, 0049₁₆, 005D₁₆ and 005E₁₆.

To generate interrupts on both rising and falling edges, set the INT_i interrupt polarity switching bit of the interrupt request cause select register (035F₁₆) to "1". Interrupt on both rising and falling edges will be generated regardless of the value set in the polarity select bit of the corresponding interrupt control register.

Figure 1.9.10 shows the Interrupt request cause select register.

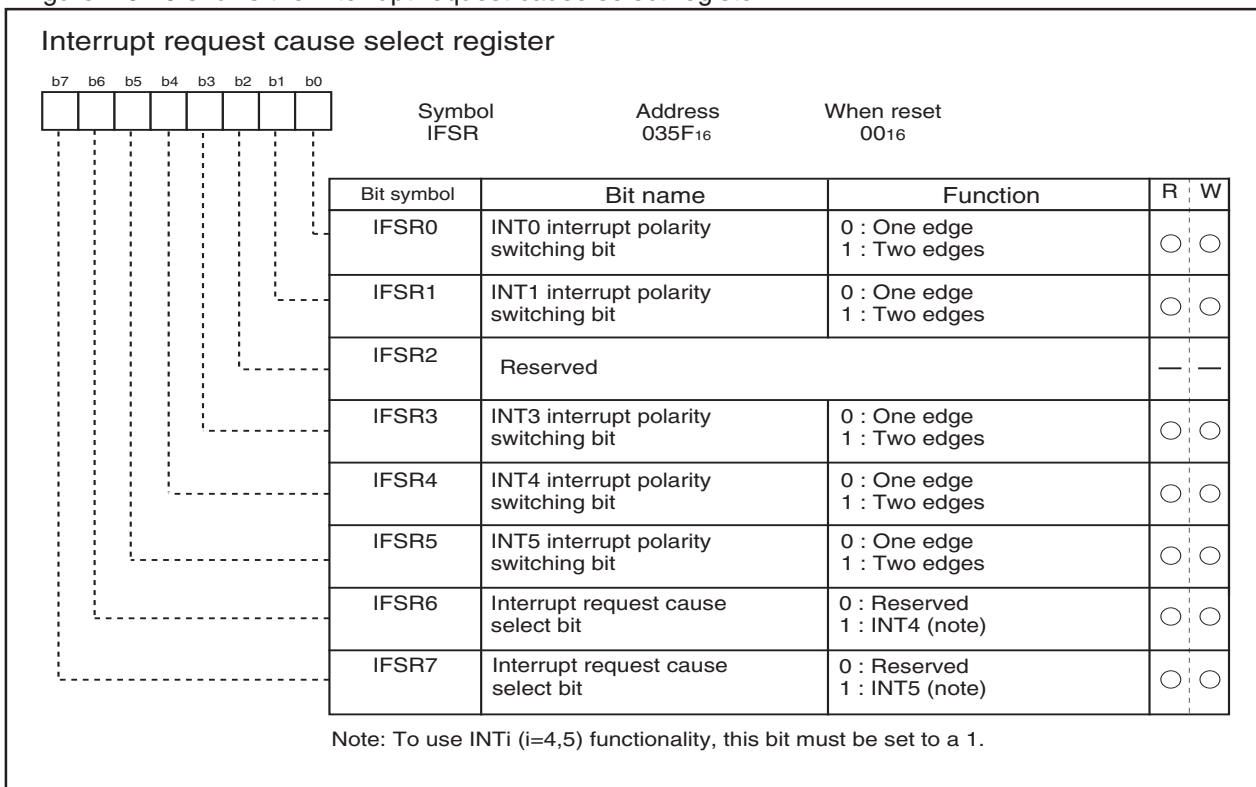

Figure 1.9.10. Interrupt request cause select register

NMI Interrupt

If enabled, an NMI interrupt is generated when the input to the P85/NMI pin changes from “H” to “L”. The NMI interrupt is a non-maskable external interrupt. The pin level can be checked in the port P85 register (bit 5 at address 03F016).

NMI is disabled by default after reset (the pin is a GPIO pin, P85) and can be enabled using bit 4 of processor mode register 2. Once enabled, it can only be disabled by a reset signal.

Key Input Interrupt

If the direction register of any of P104 to P107 is set for input and a falling edge is input to that port, a key input interrupt is generated. A key input interrupt can also be used as a key-on wakeup function for canceling the wait mode or stop mode. However, if you intend to use the key input interrupt, do not use P104 to P107 as A-D input ports. Figure 1.9.11 shows the block diagram of the key input interrupt. Note that if an “L” level is input to any pin that has not been disabled for input, inputs to the other pins are not detected as an interrupt.

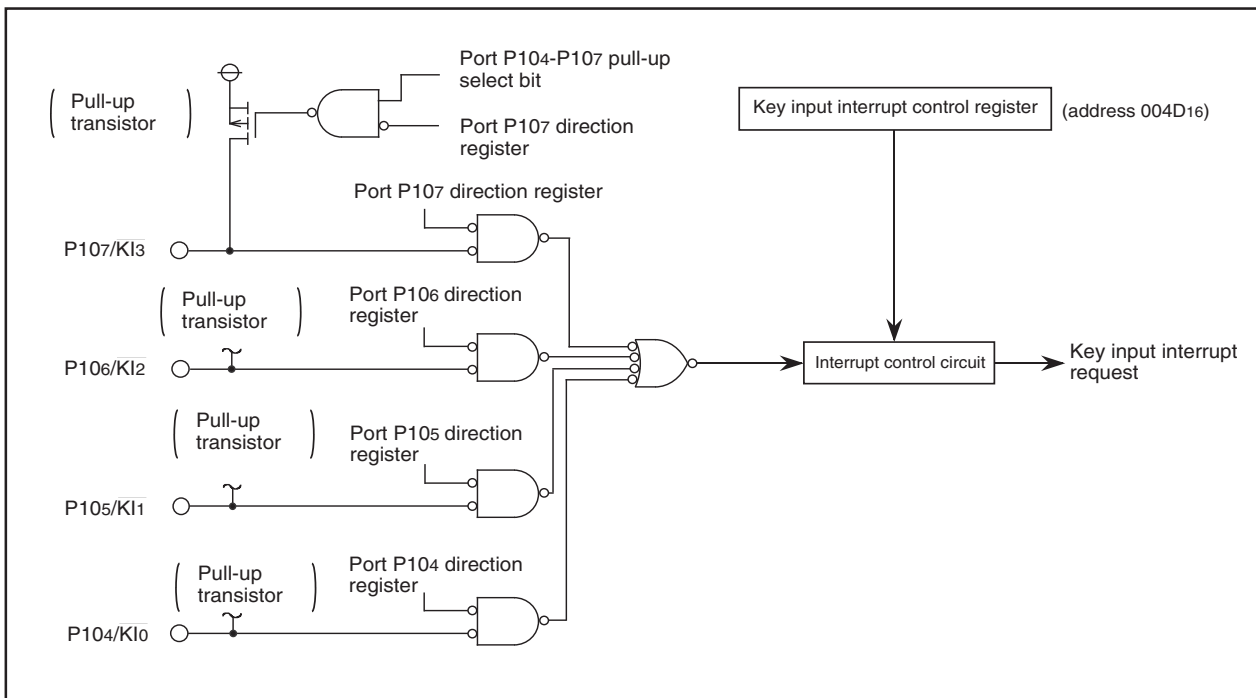

Figure 1.9.11. Block diagram of key input interrupt

Address Match Interrupt

An address match interrupt is generated when the address match interrupt address register contents match the program counter value. Four address match interrupts can be set, each of which can be enabled and disabled by an address match interrupt enable bit. Address match interrupts are not affected by the interrupt enable flag (I flag) and processor interrupt priority level (IPL). For an address match interrupt, the value of the program counter (PC) that is saved to the stack area varies depending on the instruction being executed. Note that when using the external data bus in width of 8 bits, the address match interrupt cannot be used for external area.

Figure 1.9.12 shows the address match interrupt-related registers.

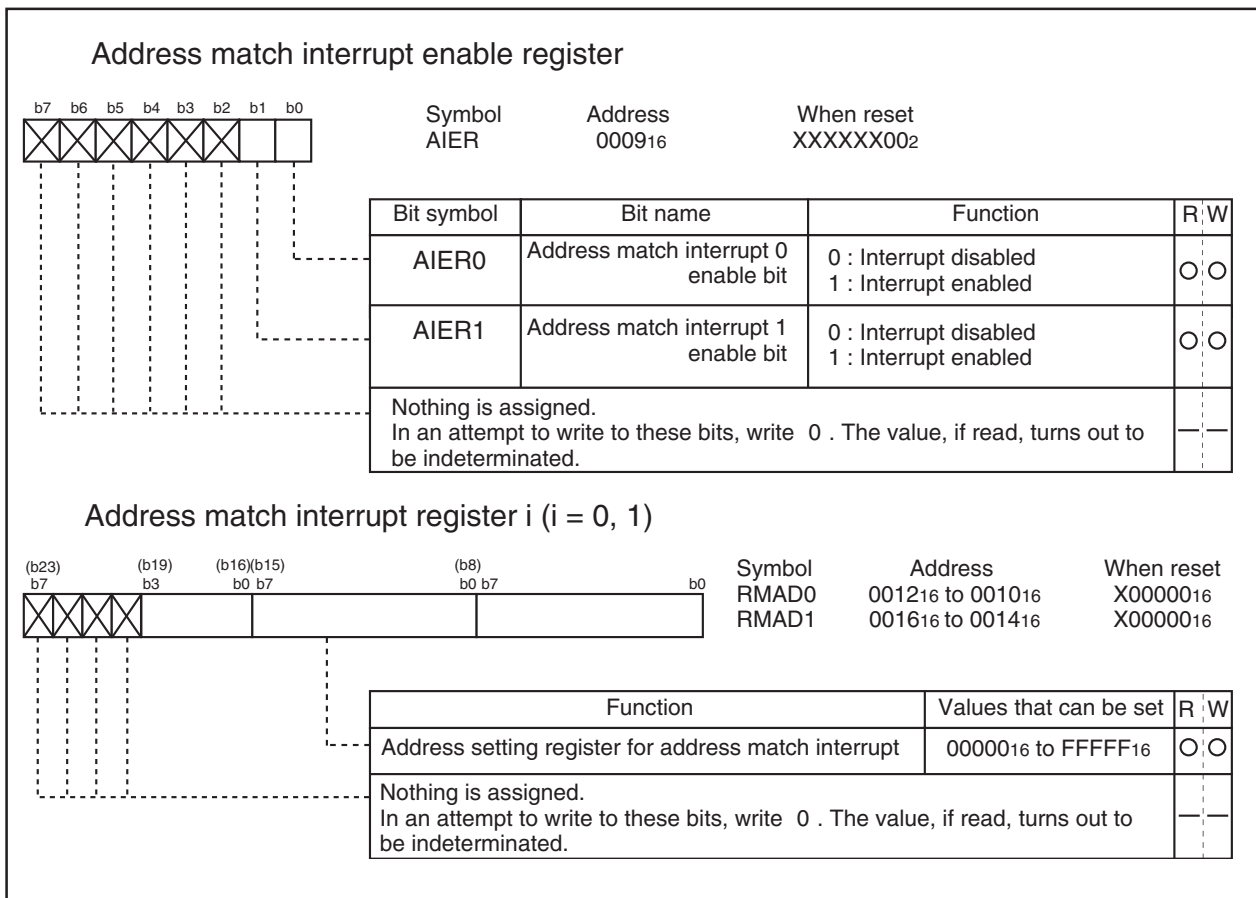

Figure 1.9.12. Address match interrupt-related registers

Precautions for Interrupts

(1) Reading address 00000₁₆

- Do not read address 00000₁₆ by software.

When a maskable interrupt is generated, the CPU reads the interrupt information (the interrupt number and interrupt request level) in the interrupt sequence. The interrupt request bit of this interrupt is written in address 00000₁₆. Therefore, reading 00000₁₆ may cancel the interrupt or generate an unexpected one.

(2) Setting the stack pointer

- The value of the stack pointer immediately after reset is initialized to 0000₁₆. Accepting an interrupt before setting a value in the stack pointer may cause a runaway program. Be sure to set a value in the stack pointer before accepting an interrupt.

When using the NMI interrupt, initialize the stack pointer at the beginning of the program. Concerning the first instruction immediately after reset, the generation of any interrupts, including the NMI interrupt, is prohibited.

(3) The NMI interrupt

- The NMI interrupt is enabled or disabled in bit4 of the processor mode register 2. It is disabled by default (the pin is used as P85) after reset. Once enabled, it stays enabled until a reset is applied.
- The NMI interrupt input level can be determined by reading the contents of the P8 register.
- If NMI is enabled, do not attempt to go into stop mode with the NMI input in the "L" state. With the NMI input in the "L" state, the CM10 is fixed to "0", therefore, any attempt to go into stop mode is turned down.
- If NMI is enabled, going into wait mode with the NMI input in the "L" state does not reduce the power consumption. With the NMI input in the "L" state, the CPU stops but the oscillation is not stop, so power consumption is not reduced. Having NMI in "L" state when going into a wait mode may also cause an unpredictable behavior of the program.
- Signal input to the NMI pin require an "L" level of '2 cycles of BCLK + 300ns' or more.

(4) External interrupt

- Either an "L" level or an "H" level of at least 250 ns width is necessary for the signal input to pins INT₀, INT₁, INT₃ through INT₅ regardless of the CPU operation clock.

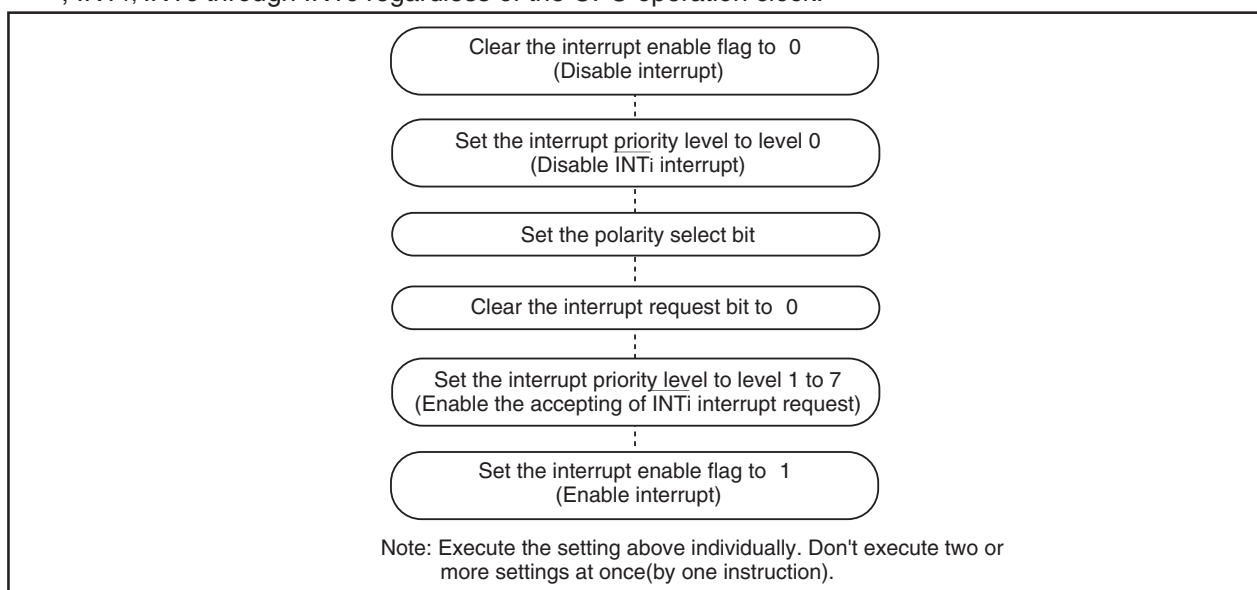

Figure 1.9.13. Switching condition of INT interrupt request

- When the polarity of the INT₀, INT₁, INT₃ through INT₅ pins is changed, the interrupt request bit is sometimes set to “1”. After changing the polarity, set the interrupt request bit to “0”. Figure 1.9.13 shows the procedure for changing the INT interrupt generate factor.

(5) Watchdog timer interrupt

- Write to the watchdog timer start register after the watchdog timer interrupt occurs (initialize watchdog timer).

(6) Rewrite the interrupt control register

Example 1:

```
INT_SWITCH1:
  FCLR  I           ; Disable interrupts.
  AND.B #00h, 0055h ; Clear TA0IC int. priority level and int. request bit.
  NOP                               ; Four NOP instructions are required when using HOLD function.
  NOP
  FSET  I           ; Enable interrupts.
```

Example 2:

```
INT_SWITCH2:
  FCLR  I           ; Disable interrupts.
  AND.B #00h, 0055h ; Clear TA0IC int. priority level and int. request bit.
  MOV.W MEM, R0    ; Dummy read.
  FSET  I           ; Enable interrupts.
```

Example 3:

```
INT_SWITCH3:
  PUSHC FLG        ; Push Flag register onto stack
  FCLR  I           ; Disable interrupts.
  AND.B #00h, 0055h ; Clear TA0IC int. priority level and int. request bit.
  POPC  FLG        ; Enable interrupts.
```

The reason why two NOP instructions (four when using the HOLD function) or dummy read are inserted before FSET I in Examples 1 and 2 is to prevent the interrupt enable flag I from being set before the interrupt control register is rewritten due to effects of the instruction queue.

- To rewrite the interrupt control register, do so at a point where an interrupt request for that register is not generated. If there is possibility of the interrupt request occur, disable the interrupt before rewriting the interrupt control register. Some program examples are described as follow:

When changing an interrupt control register with interrupts enabled, please read the following precautions on instructions used before changing the register.

(1) Changing a non-interrupt request bit

If an interrupt request for an interrupt control register is generated during an instruction to rewrite the register is being executed, there is a case that the interrupt request bit is not set and consequently the interrupt is ignored. This will depend on the instruction. If this creates problems, use the instructions below to change the register.

Instructions : AND, OR, BCLR, BSET

(2) Changing the interrupt request bit

When attempting to clear the interrupt request bit of an interrupt control register, the interrupt request bit is not cleared sometimes. This will depend on the instruction. If this creates problems, use the instructions below to change the register.

Instructions : MOV

Watchdog Timer

The watchdog timer has the function of detecting when the program is out of control. Therefore, we recommend using the watchdog timer to improve reliability of a system. The watchdog timer is a 15-bit counter which down-counts the clock derived by dividing the BCLK using the prescaler. Whether a watchdog timer interrupt is generated or reset is selected when an underflow occurs in the watchdog timer. When the watchdog timer interrupt is selected, write to the watchdog timer start register after the watchdog timer interrupt occurs (initialize watchdog timer). Watchdog timer interrupt is selected when bit 2 (PM12) of the processor mode register 1 (address 000516) is "0" and reset is selected when PM12 is "1". No value other than "1" can be written in PM12. Once when reset is selected (PM12="1"), watchdog timer interrupt cannot be selected by software.

When X_{IN} is selected for the BCLK, bit 7 of the watchdog timer control register (address 000F16) selects the prescaler division ratio (by 16 or by 128). When X_{CIN} is selected as the BCLK, the prescaler is set for division by 2 regardless of bit 7 of the watchdog timer control register (address 000F16). Thus the watchdog timer's period can be calculated as given below. The watchdog timer's period is, however, subject to an error due to the prescaler.

With X_{IN} chosen for BCLK

$$\text{Watchdog timer period} = \frac{\text{prescaler dividing ratio (16 or 128)} \times \text{watchdog timer count (32768)}}{\text{BCLK}}$$

With X_{CIN} chosen for BCLK

$$\text{Watchdog timer period} = \frac{\text{prescaler dividing ratio (2)} \times \text{watchdog timer count (32768)}}{\text{BCLK}}$$

For example, suppose that BCLK runs at 16 MHz and that 16 has been chosen for the dividing ratio of the prescaler, then the watchdog timer's period becomes approximately 32.8 ms.

The watchdog timer is initialized by writing to the watchdog timer start register (address 000E16) and when a watchdog timer interrupt request is generated. The prescaler is initialized only when the microcomputer is reset. After a reset is cancelled, the watchdog timer and prescaler are both stopped. The count is started by writing to the watchdog timer start register (address 000E16). In stop mode, wait mode and hold state, the watchdog timer and prescaler are stopped. Counting is resumed from the held value when the modes or state are released.

Also PM12 is initialized only when reset. The watchdog timer interrupt is selected after reset is cancelled. Figure 1.10.1 shows the block diagram of the watchdog timer. Figure 1.10.2 shows the watchdog timer-related registers.

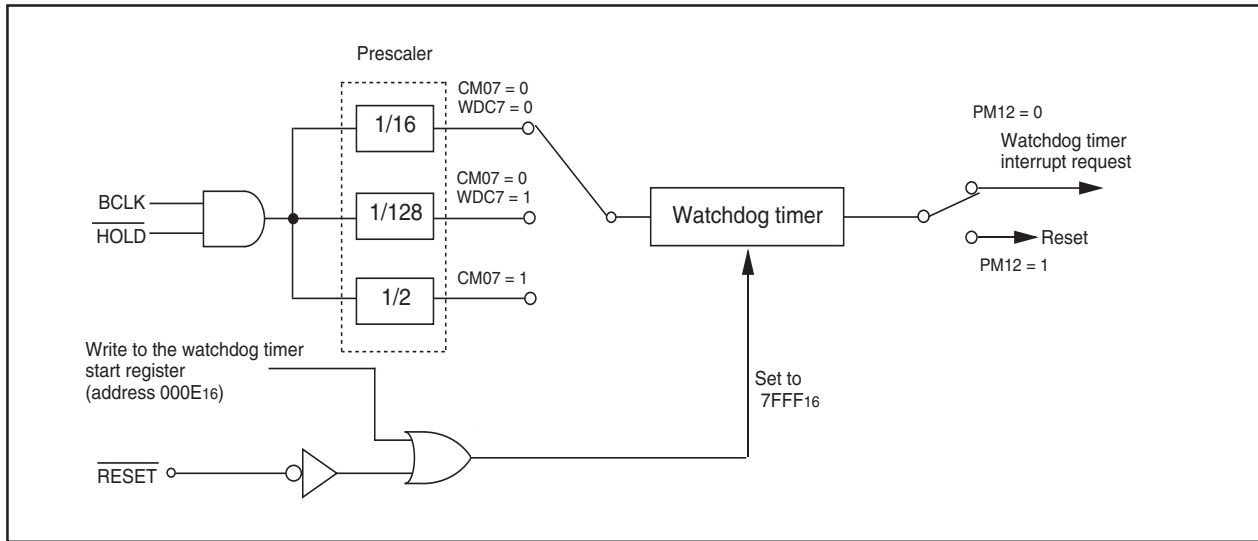

Figure 1.10.1. Block diagram of watchdog timer

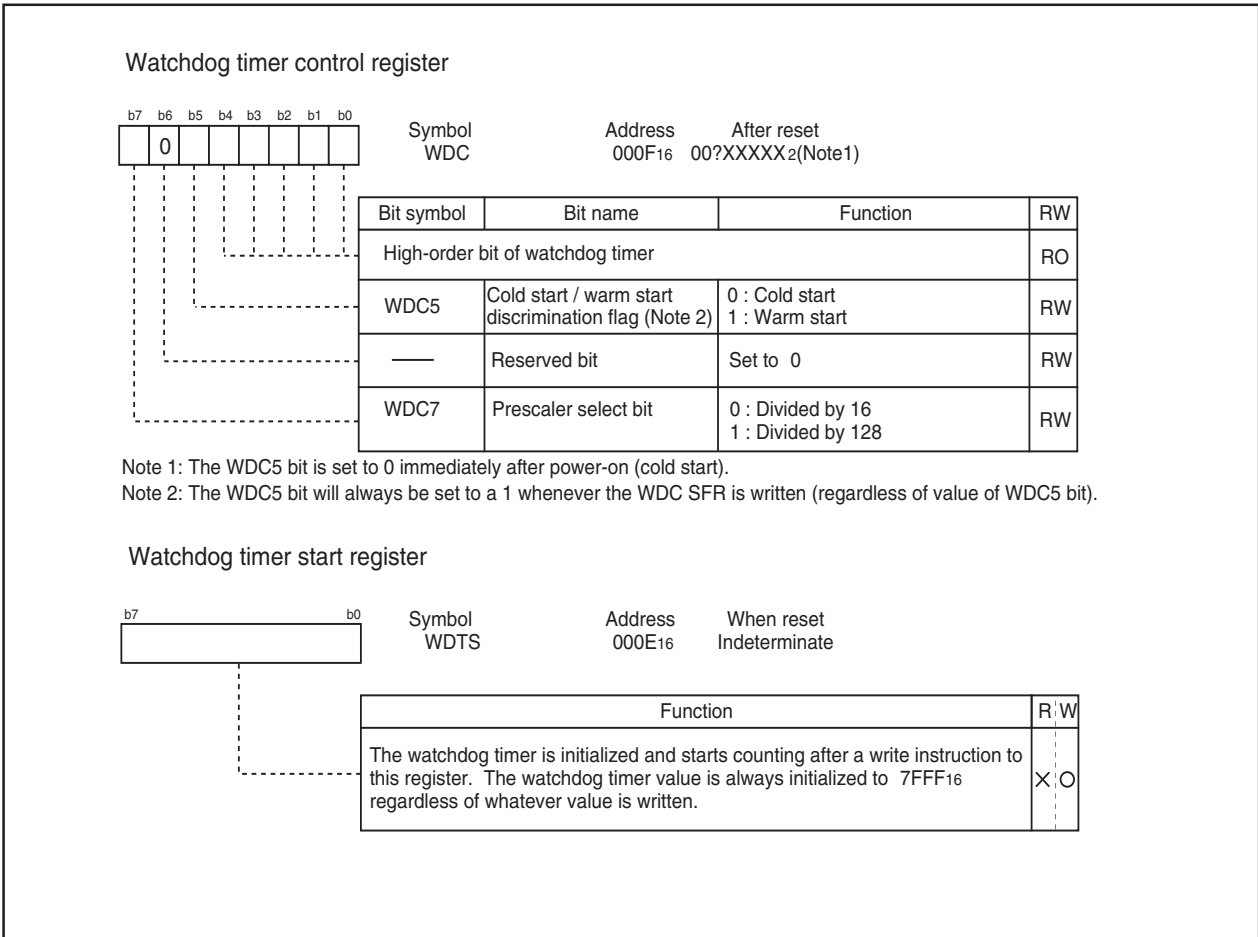

Figure 1.10.2. Watchdog timer control and start registers

DMAC

This microcomputer has two DMAC (direct memory access controller) channels that allow data to be sent to memory without using the CPU. DMAC shares the same data bus with the CPU. The DMAC is given a higher right of using the bus than the CPU, which leads to working the cycle stealing method. On this account, the operation from the occurrence of DMA transfer request signal to the completion of 1-word (16-bit) or 1-byte (8-bit) data transfer can be performed at high speed. Figure 1.11.1 shows the block diagram of the DMAC. Table 1.11.1 shows the DMAC specifications. Figures 1.11.2 to 1.11.4 show the registers used by the DMAC.

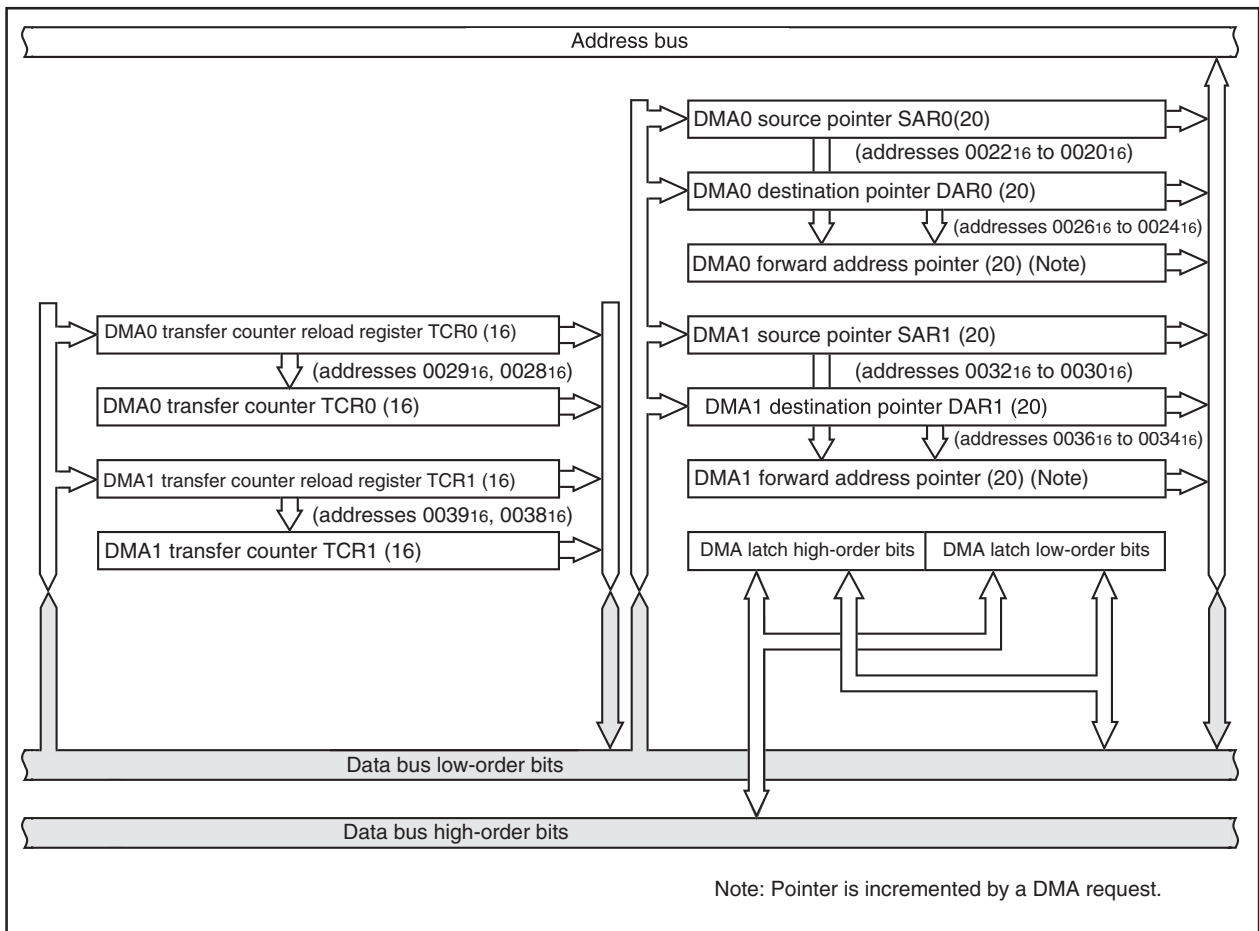

Figure 1.11.1. Block diagram of DMAC

Either a write to the software DMA request bit or an interrupt request factor are used as a DMA transfer request signal. The DMA transfer is not affected by the interrupt enable flag (I flag) nor by the interrupt priority level. The DMA transfer does not affect interrupts.

If the DMAC is active (the DMA enable bit is set to 1), data transfer starts every time a DMA transfer request signal occurs. If the cycle of the occurrences of DMA transfer request signals is higher than the DMA transfer cycle, there can be instances in which the number of transfer requests do not agree with the number of transfers. For details, see the description of the DMA request bit.

Table 1.11.1. DMAC specifications

Item	Specification
No. of channels	2 (cycle steal method)
Transfer memory space	<ul style="list-style-type: none"> • From any address in the 1M bytes space to a fixed address • From a fixed address to any address in the 1M bytes space • From a fixed address to a fixed address (Note that DMA-related registers [0020 ₁₆ to 003F ₁₆] cannot be accessed)
Maximum No. of bytes transferred	128K bytes (with 16-bit transfers) or 64K bytes (with 8-bit transfers)
DMA request factors (Note)	Falling edge of INT0 or INT1 or both edge Timer A0 to timer A4 interrupt requests Timer B0 to timer B2 interrupt requests UART0 transfer and reception interrupt requests UART1 transfer and reception interrupt requests UART2 transfer and reception interrupt requests A-D conversion interrupt requests Software triggers
Channel priority	DMA0 takes precedence if DMA0 and DMA1 requests are generated simultaneously
Transfer unit	8 bits or 16 bits
Transfer address direction	forward/fixed (forward direction cannot be specified for both source and destination simultaneously)
Transfer mode	<ul style="list-style-type: none"> • Single transfer mode After the transfer counter underflows, the DMA enable bit turns to "0", and the DMAC turns inactive • Repeat transfer mode After the transfer counter underflows, the value of the transfer counter reload register is reloaded to the transfer counter. The DMAC remains active unless a "0" is written to the DMA enable bit.
DMA interrupt request generation timing	When an underflow occurs in the transfer counter
Active	When the DMA enable bit is set to "1", the DMAC is active. When the DMAC is active, data transfer starts every time a DMA transfer request signal occurs.
Inactive	<ul style="list-style-type: none"> • When the DMA enable bit is set to "0", the DMAC is inactive. • After the transfer counter underflows in single transfer mode At the time of starting data transfer immediately after turning the DMAC active, the value of one of source pointer and destination pointer - the one specified for the forward direction- is reloaded to the forward direction address pointer, and the value of the transfer counter reload register is reloaded to the transfer counter.
Writing to register	Registers specified for forward direction transfer are always write enabled. Registers specified for fixed address transfer are write-enabled when the DMA enable bit is "0".
Reading the register	Can be read at any time. However, when the DMA enable bit is "1", reading the register set up as the forward register is the same as reading the value of the forward address pointer.

Note: DMA transfer is not effective to any interrupt. DMA transfer is affected neither by the interrupt enable flag (I flag) nor by the interrupt priority level.

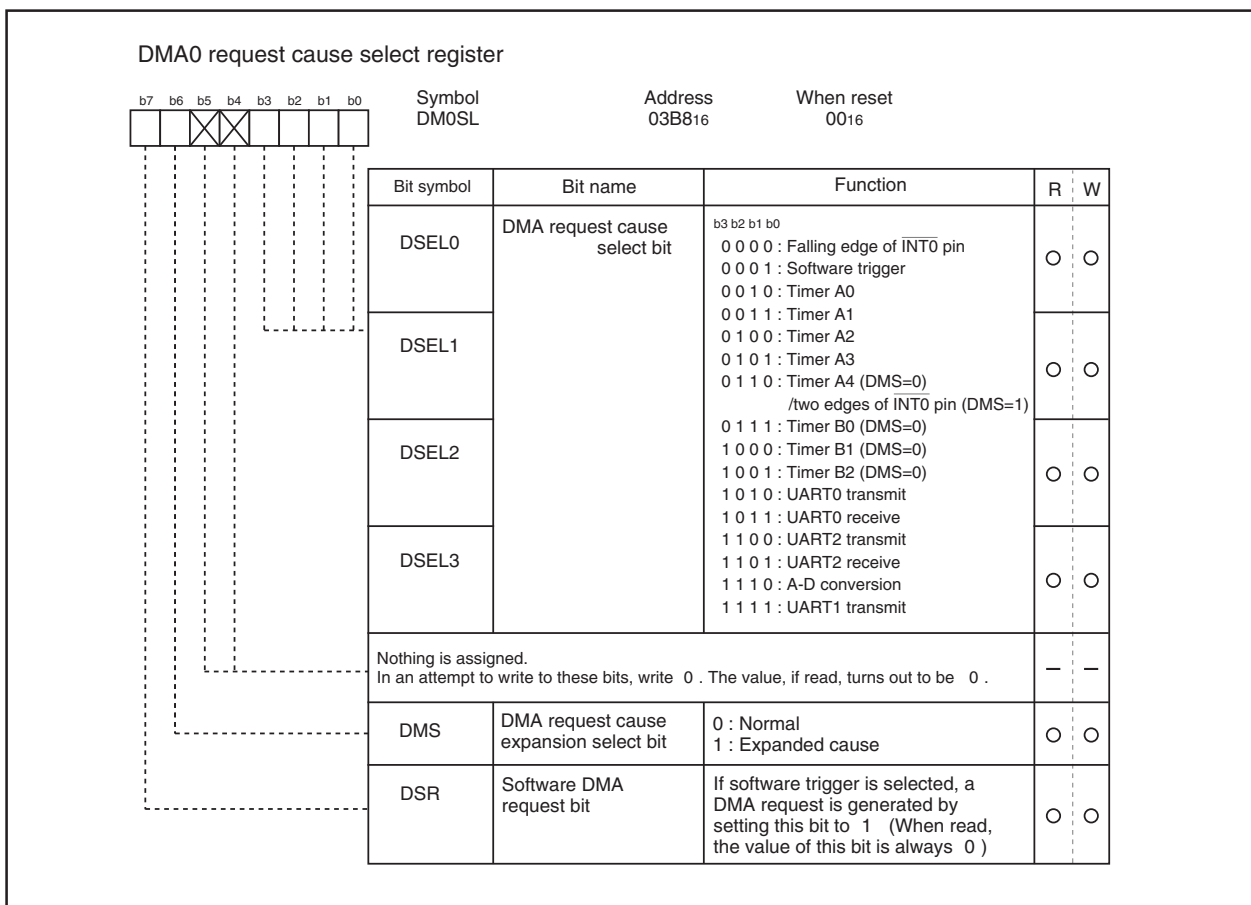

Figure 1.11.2. DMAC register (1)

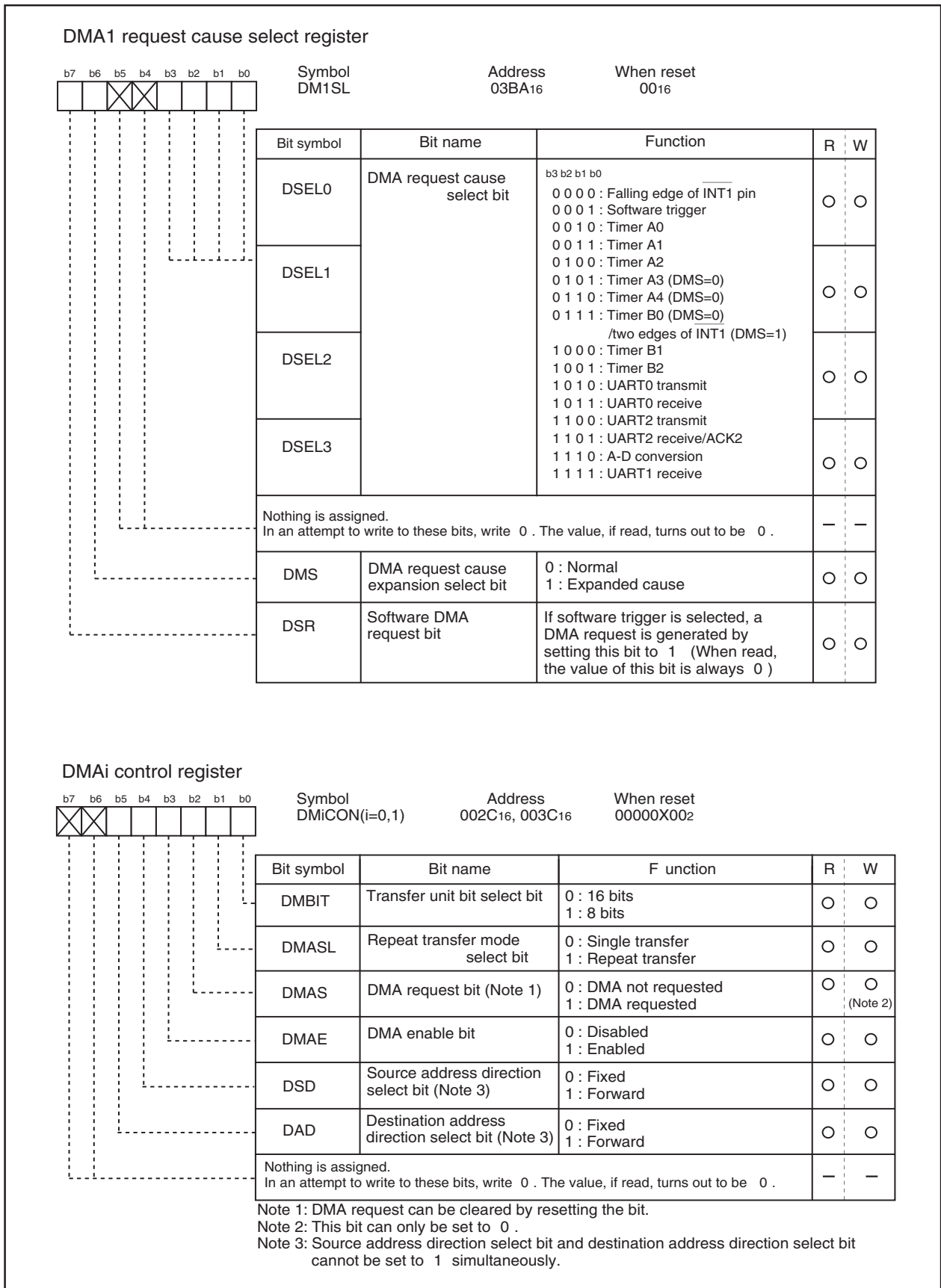

Figure 1.11.3. DMAC register (2)

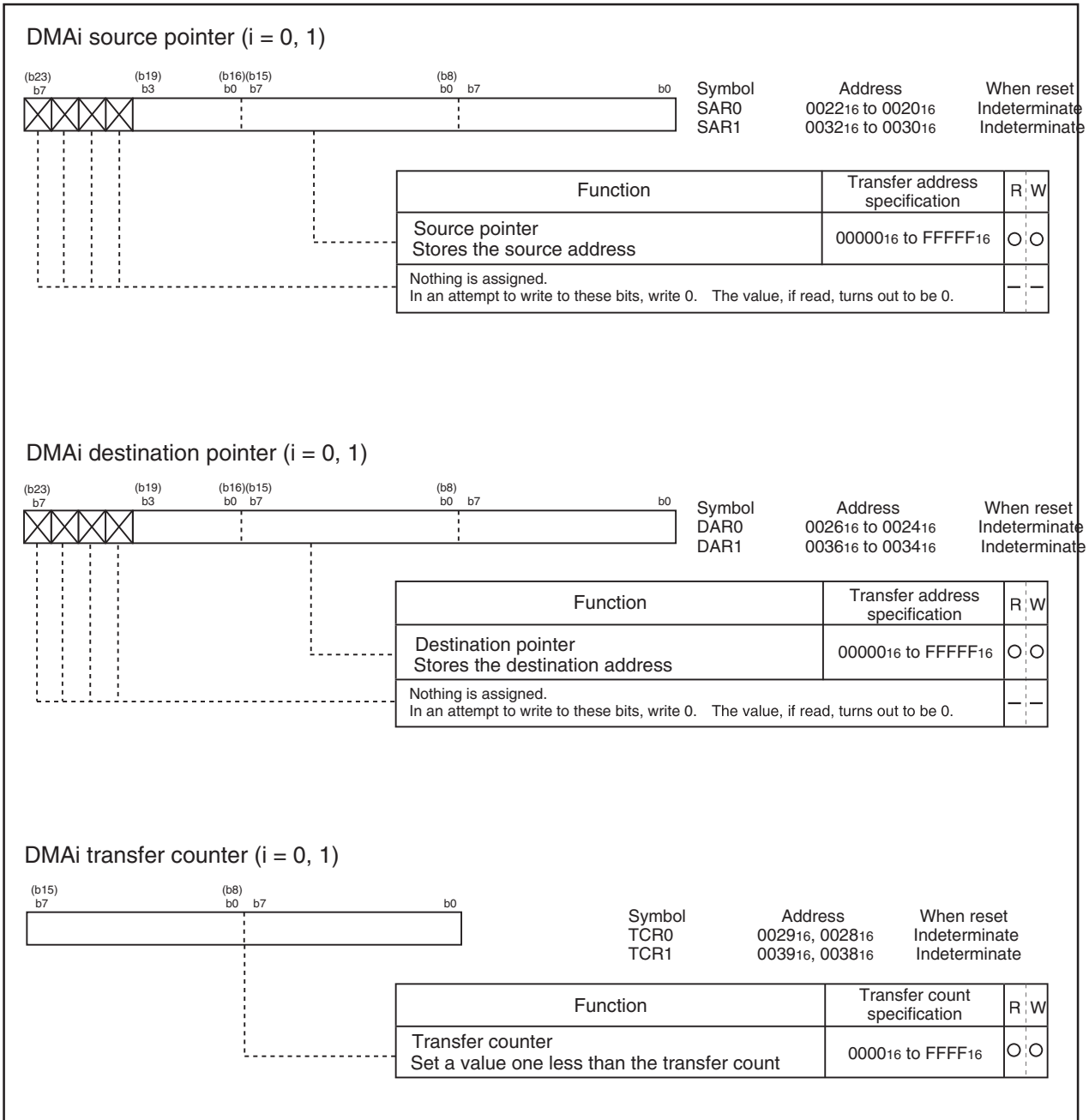

Figure 1.11.4. DMAC register (3)

(1) Transfer cycle

The transfer cycle consists of the bus cycle in which data is read from memory or from the SFR area (source read) and the bus cycle in which the data is written to memory or to the SFR area (destination write). The number of read and write bus cycles depends on the source and destination addresses. Also, the bus cycle itself is longer when software waits are inserted.

(a) Effect of source and destination addresses

When 16-bit data is transferred on a 16-bit data bus, and the source and destination both start at odd addresses, there are one more source read cycle and destination write cycle than when the source and destination both start at even addresses.

(b) Effect of software wait

When the SFR area or a memory area with a software wait is accessed, the number of cycles is increased for the wait by 1 bus cycle. The length of the cycle is determined by BCLK.

Figure 1.11.5 shows the example of the transfer cycles for a source read. For convenience, the destination write cycle is shown as one cycle and the source read cycles for the different conditions are shown. In reality, the destination write cycle is subject to the same conditions as the source read cycle, with the transfer cycle changing accordingly. When calculating the transfer cycle, remember to apply the respective conditions to both the destination write cycle and the source read cycle. For example (2) in Figure 1.11.5, if 16-bit data is being transferred from an odd source address to an odd destination address, two bus cycles are required for both the source read cycle and the destination write cycle.

(2) DMAC transfer cycles

Any combination of even or odd transfer read and write addresses is possible. Table 1.11.2 shows the number of DMAC transfer cycles.

The number of DMAC transfer cycles can be calculated as follows:

$$\text{No. of transfer cycles per transfer unit} = \text{No. of read cycles} \times j + \text{No. of write cycles} \times k$$

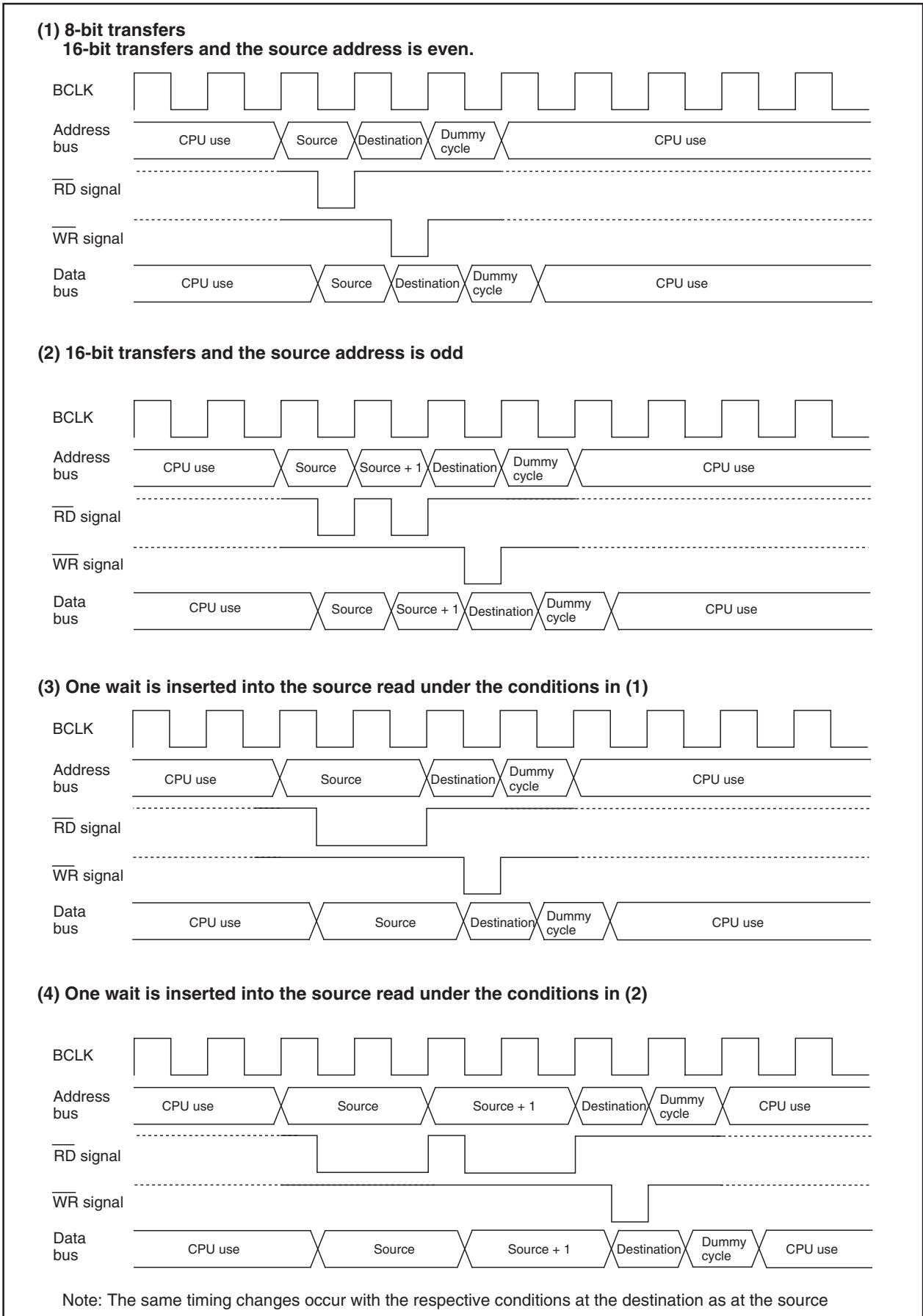

Figure 1.11.5. Example of the transfer cycles for a source read

Table 1.11.2. No. of DMAC transfer cycles

			Single Chip Mode	
Transfer Unit	Bus Width	Access Address	No. of Read Cycles	No. of Write Cycles
8-bit transfers (DMBIT="1")	16 bit	Even	1	1
		Odd	1	1
16-bit transfers (DMBIT="0")	16 bit	Even	1	1
		Odd	2	2

Coefficient j, k

Internal Memory		
Internal ROM/RAM No Wait	Internal ROM/RAM With Wait	SFR Area
1	2	3

DMA enable bit

Setting the DMA enable bit to “1” makes the DMAC active. The DMAC carries out the following operations at the time data transfer starts immediately after DMAC is turned active.

- (1) Reloads the value of one of the source pointer and the destination pointer - the one specified for the forward direction - to the forward direction address pointer.
- (2) Reloads the value of the transfer counter reload register to the transfer counter.

Thus overwriting “1” to the DMA enable bit with the DMAC being active carries out the operations given above, so the DMAC operates again from the initial state at the instant “1” is overwritten to the DMA enable bit.

DMA request bit

The DMAC can generate a DMA transfer request signal triggered by a factor chosen in advance out of DMA request factors for each channel.

DMA request factors include the following.

- * Factors effected by using the interrupt request signals from the built-in peripheral functions and software DMA factors (internal factors) effected by a program.
- * External factors effected by utilizing the input from external interrupt signals.

For the selection of DMA request factors, see the descriptions of the DMA_i factor selection register.

The DMA request bit turns to “1” if the DMA transfer request signal occurs regardless of the DMAC's state (regardless of whether the DMA enable bit is set to “1” or “0”). It turns to “0” immediately before data transfer starts.

In addition, it can be set to “0” by use of a program, but cannot be set to “1”.

There can be instances in which a change in DMA request factor selection bit causes the DMA request bit to turn to “1”. So be sure to set the DMA request bit to “0” after the DMA request factor selection bit is changed. The DMA request bit turns to “1” if a DMA transfer request signal occurs, and turns to “0” immediately before data transfer starts. If the DMAC is active, data transfer starts immediately, so the value of the DMA request bit, if read by use of a program, turns out to be “0” in most cases. To examine whether the DMAC is active, read the DMA enable bit.

Here follows the timing of changes in the DMA request bit.

(1) Internal factors

Except the DMA request factors triggered by software, the timing for the DMA request bit to turn to “1” due to an internal factor is the same as the timing for the interrupt request bit of the interrupt control register to turn to “1” due to several factors.

Turning the DMA request bit to “0” due to an internal factor is timed to be effected immediately before the transfer starts.

(2) External factors

An external factor is a factor caused to occur by the leading edge of input from the INT_i pin (i depends on which DMAC channel is used).

Selecting the INT_i pins as external factors using the DMA request factor selection bit causes input from these pins to become the DMA transfer request signals.

The timing for the DMA request bit to turn to “1” when an external factor is selected synchronizes with the signal's edge applicable to the function specified by the DMA request factor selection bit (synchronizes with the trailing edge of the input signal to each INT_i pin, for example).

With an external factor selected, the DMA request bit is timed to turn to “0” immediately before data transfer starts similarly to the state in which an internal factor is selected.

(3) The priorities of channels and DMA transfer timing

If a DMA transfer request signal falls on a single sampling cycle (a sampling cycle means one period from the leading edge to the trailing edge of BCLK), the DMA request bits of applicable channels concurrently turn to "1". If the channels are active at that moment, DMA0 is given a high priority to start data transfer. When DMA0 finishes data transfer, it gives the bus right to the CPU. When the CPU finishes single bus access, then DMA1 starts data transfer and gives the bus right to the CPU.

An example in which DMA transfer is carried out in minimum cycles at the time when DMA transfer request signals due to external factors concurrently occur.

Figure 1.11.6 shows the DMA transfer effected by external factors.

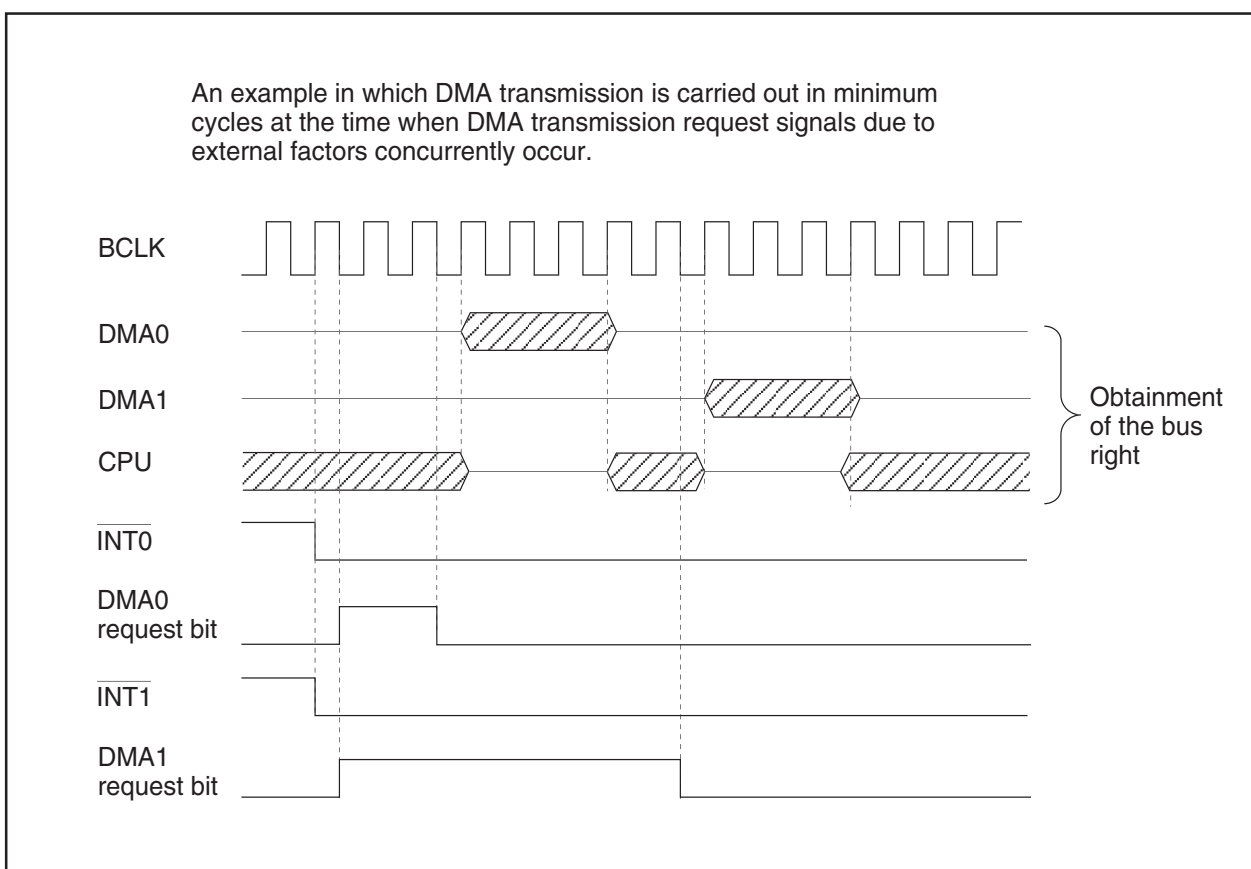

Figure 1.11.6. An example of DMA transfer effected by external factors

Timers

There are eight 16-bit timers. These timers can be classified by function into timers A (five) and timers B (three). All these timers function independently. Figures 1.12.1 and 1.12.2 show the block diagram of timers.

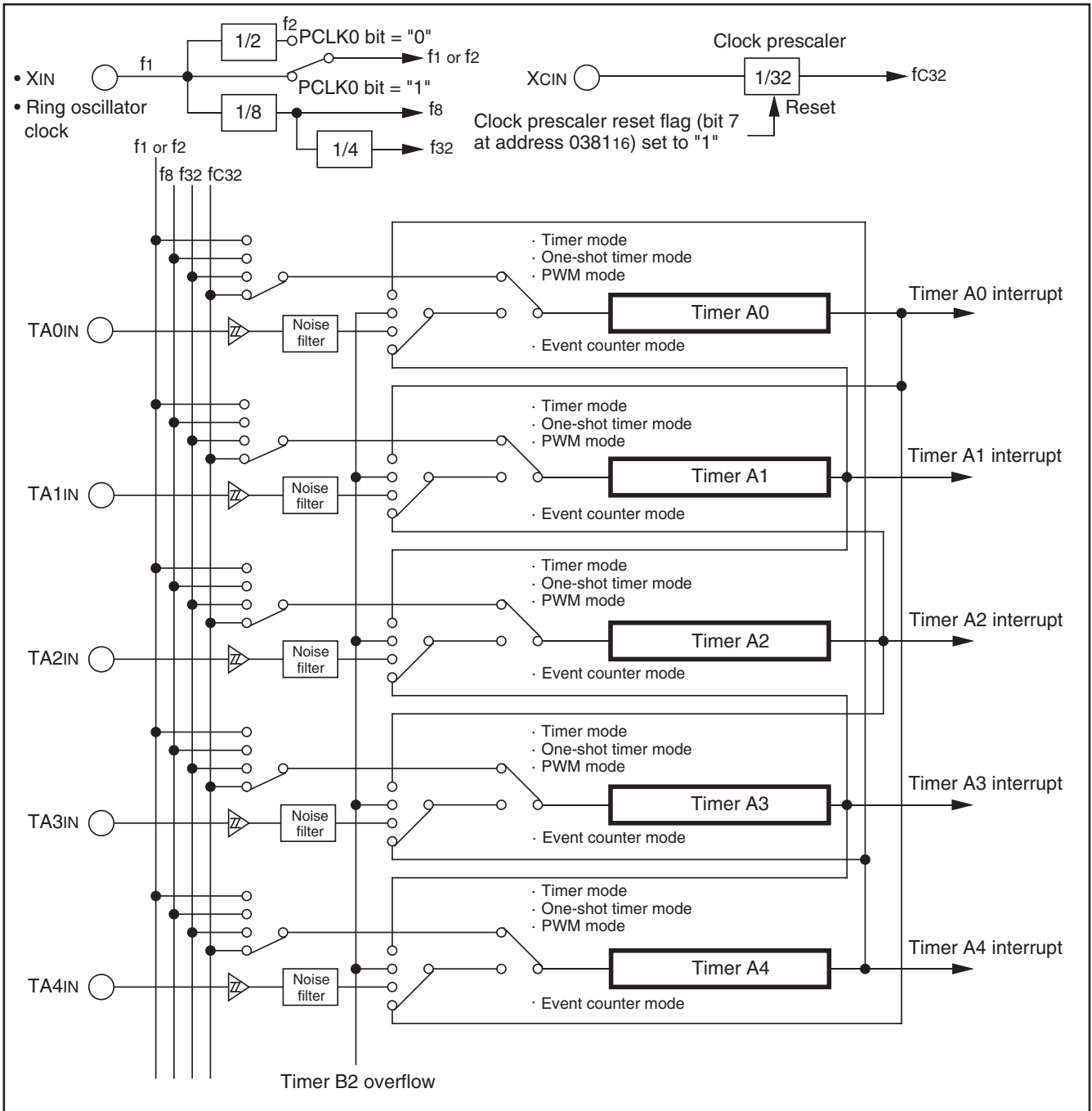

Figure 1.12.1. Timer A block diagram

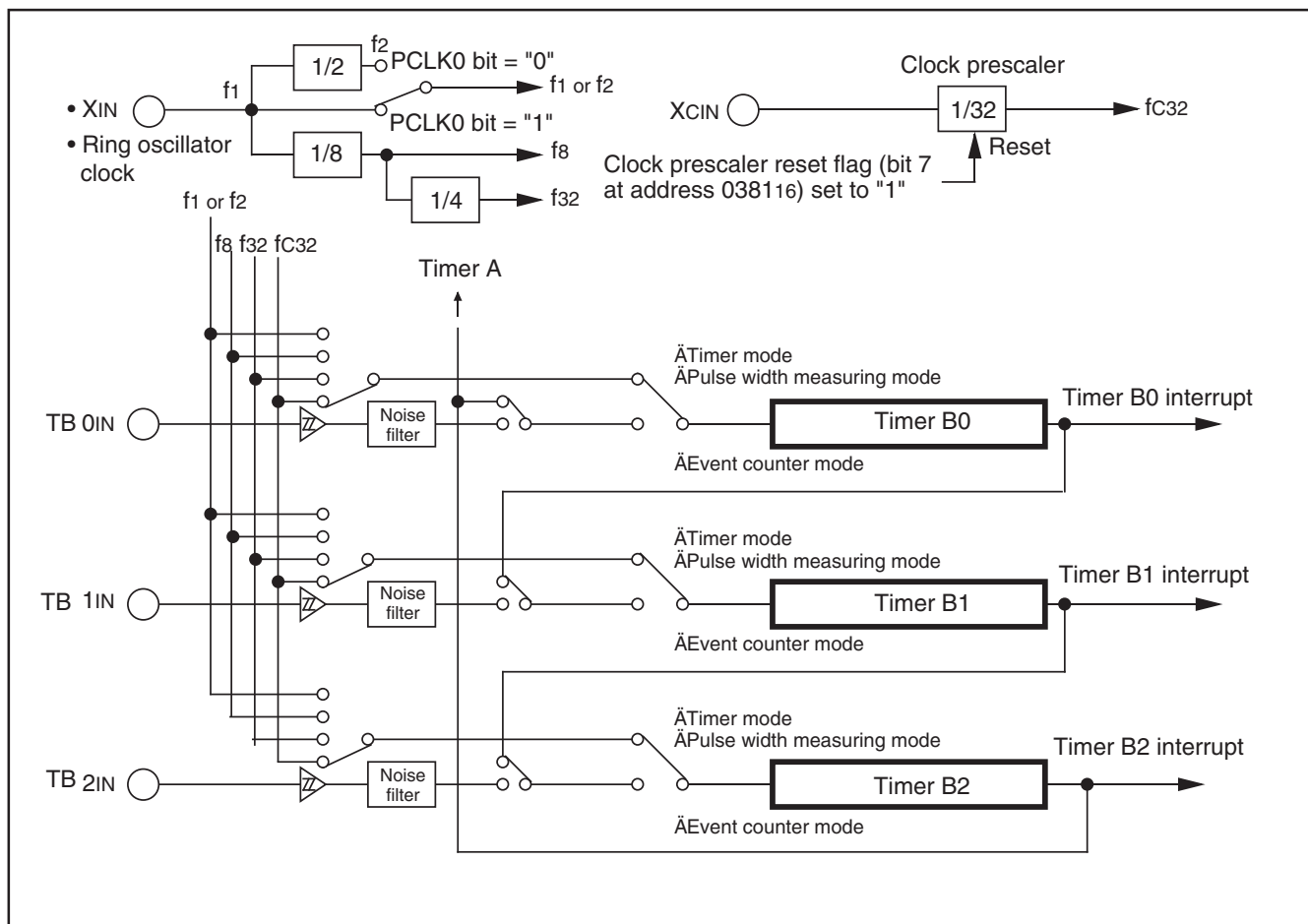

Figure 1.12.2. Timer B block diagram

Timer A

Figure 1.12.3 shows the block diagram of timer A. Figures 1.12.4 to 1.12.6 show the timer A-related registers.

Except in event counter mode, timers A0 through A4 all have the same function. Use the timer Ai mode register (i = 0 to 4) bits 0 and 1 to choose the desired mode.

Timer A has the four operation modes listed as follows:

- Timer mode: The timer counts an internal count source.
- Event counter mode: The timer counts pulses from an external source or a timer over flow.
- One-shot timer mode: The timer stops counting when the count reaches "000016".
- Pulse width modulation (PWM) mode: The timer outputs pulses of a given width.

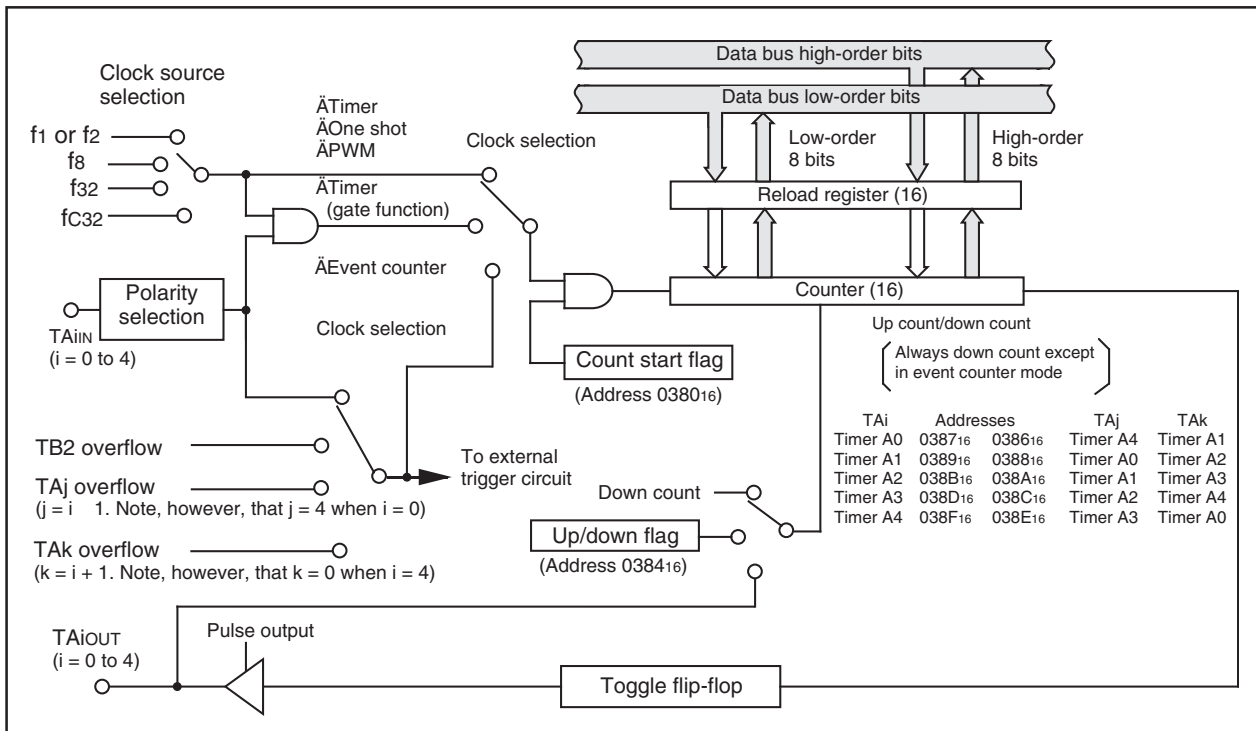

Figure 1.12.3. Block diagram of timer A

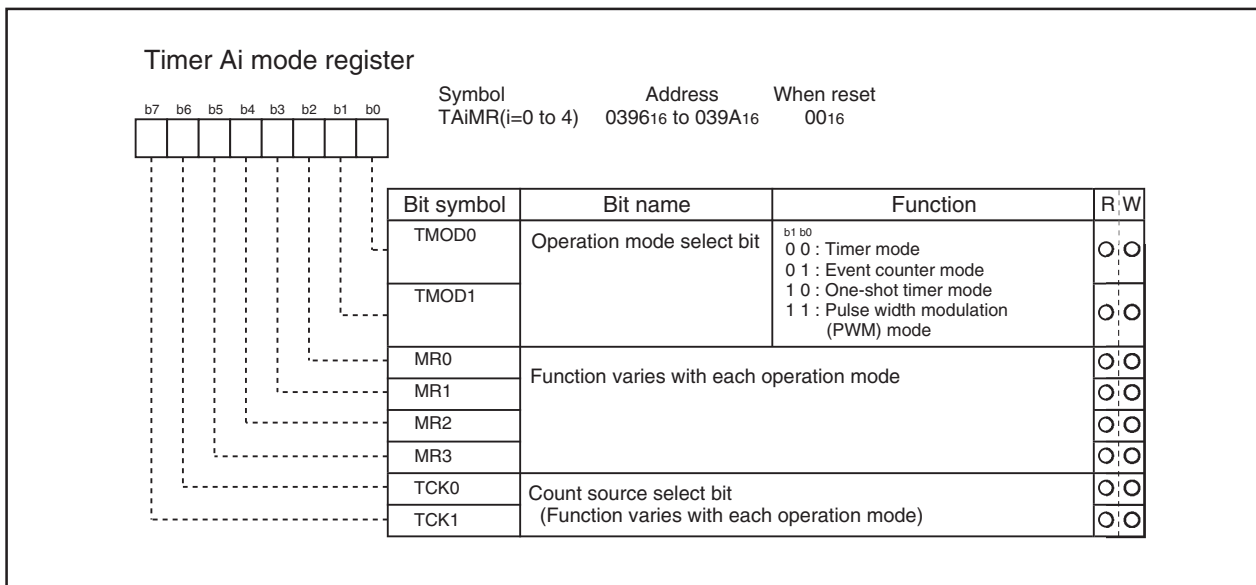

Figure 1.12.4. Timer A-related registers (1)

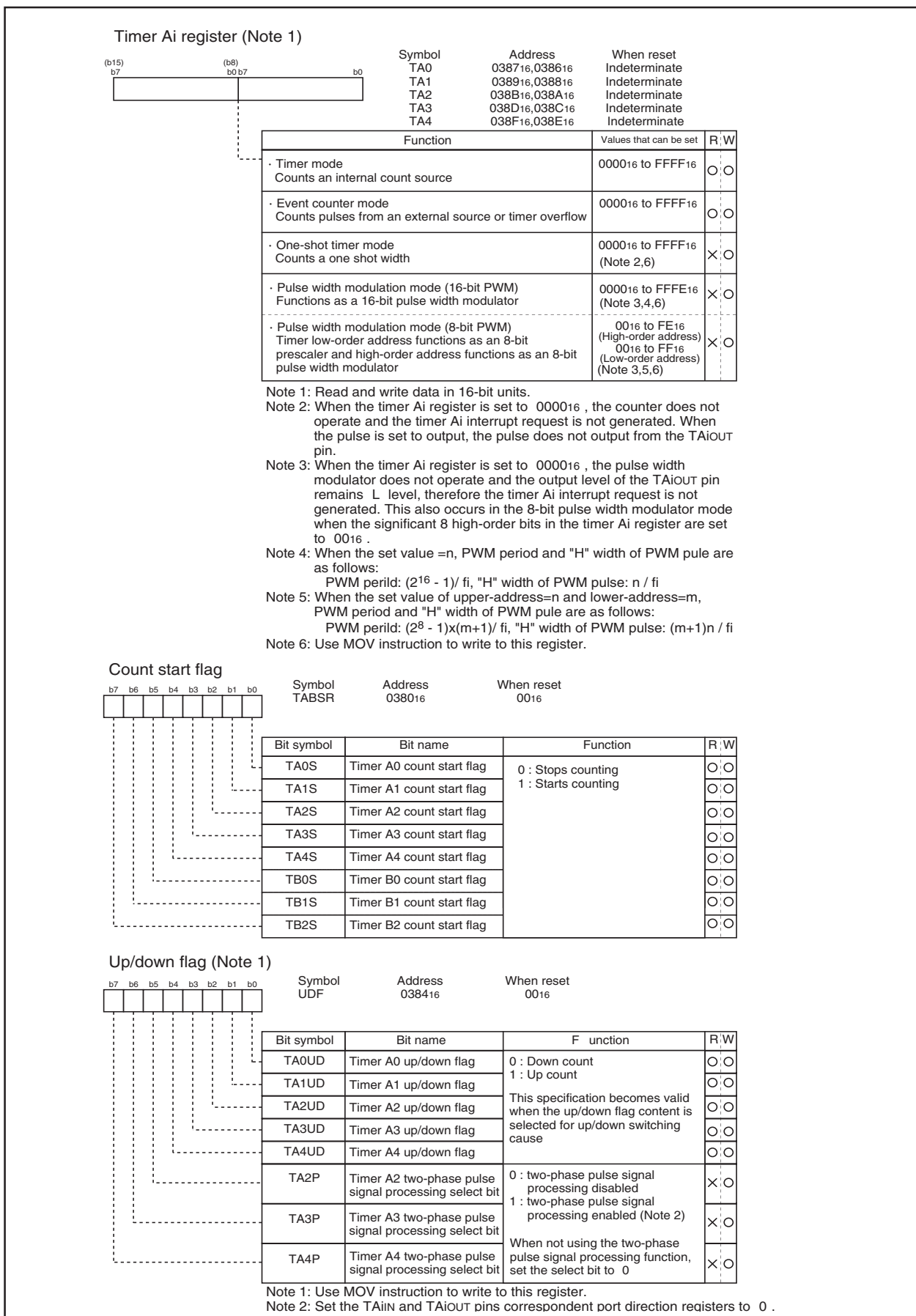
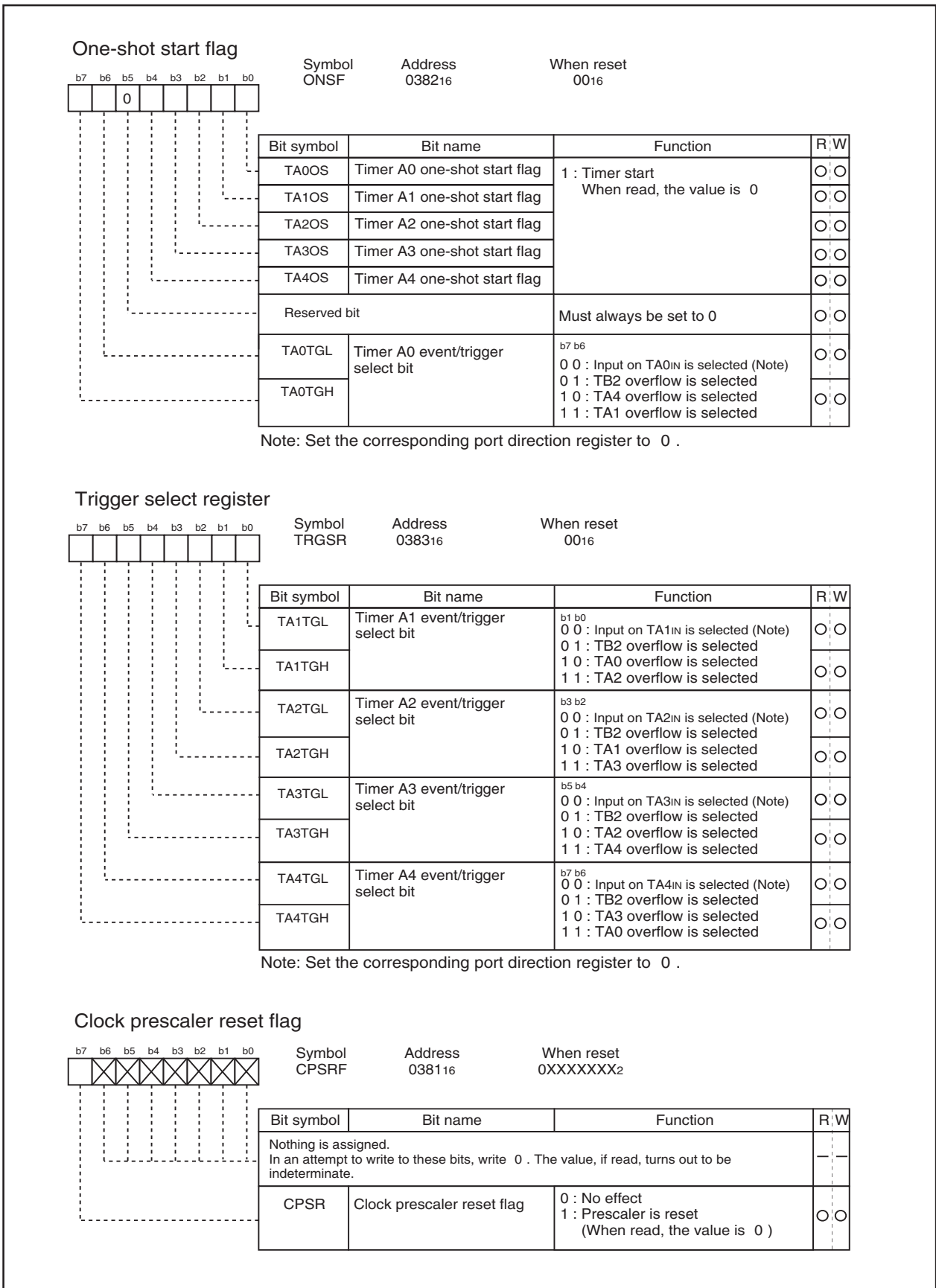

Figure 1.12.5. Timer A-related registers (2)



(1) Timer mode

In this mode, the timer counts an internally generated count source. (See Table 1.12.1.) Figure 1.12.7 shows the timer Ai mode register in timer mode.

Table 1.12.1. Specifications of timer mode

Item	Specification
Count source	f1, f2, f8, f32, fC32
Count operation	<ul style="list-style-type: none"> Down count When the timer underflows, it reloads the reload register contents before continuing counting
Divide ratio	1/(n+1) n : Set value
Count start condition	Count start flag is set (= 1)
Count stop condition	Count start flag is reset (= 0)
Interrupt request generation timing	When the timer underflows
TAiIN pin function	Programmable I/O port or gate input
TAiOUT pin function	Programmable I/O port or pulse output
Read from timer	Count value can be read out by reading timer Ai register
Write to timer	<ul style="list-style-type: none"> When counting stopped When a value is written to timer Ai register, it is written to both reload register and counter When counting in progress When a value is written to timer Ai register, it is written to only reload register (Transferred to counter at next reload time)
Select function	<ul style="list-style-type: none"> Gate function Counting can be started and stopped by the TAiIN pin's input signal Pulse output function Each time the timer underflows, the TAiOUT pin's polarity is reversed

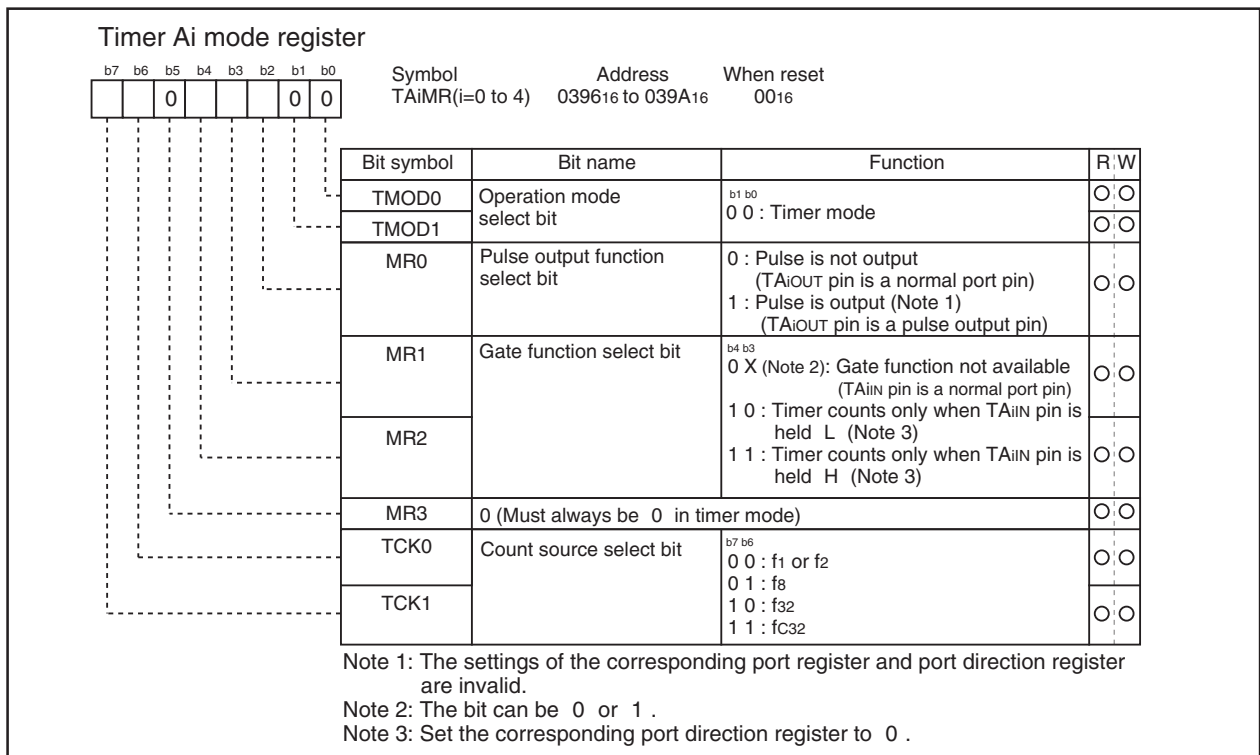

Figure 1.12.7. Timer Ai mode register in timer mode

Event Counter Mode

In this mode, the timer counts an external signal or an internal timer's overflow. Timers A0 and A1 can count a single-phase external signal. Timers A2, A3, and A4 can count a single-phase and a two-phase external signal. Table 1.12.2 lists timer specifications when counting a single-phase external signal. Figure 1.12.8 shows the timer Ai mode register in event counter mode.

Table 1.12.3 lists timer specifications when counting a two-phase external signal. Figure 1.12.9 shows the timer Ai mode register in event counter mode.

Table 1.12.2. Timer specifications in event counter mode (when not processing two-phase pulse signal)

Item	Specification
Count source	<ul style="list-style-type: none"> External signals input to TAIIn pin (effective edge can be selected by software) TB2 overflow, TAJ overflow
Count operation	<ul style="list-style-type: none"> Up count or down count can be selected by external signal or software When the timer overflows or underflows, it reloads the reload register contents before continuing counting (Note)
Divide ratio	$1 / (FFFF_{16} - n + 1)$ for up count $1 / (n + 1)$ for down count n : Set value
Count start condition	Count start flag is set (= 1)
Count stop condition	Count start flag is reset (= 0)
Interrupt request generation timing	The timer overflows or underflows
TAIIn pin function	Programmable I/O port or count source input
TAIOUt pin function	Programmable I/O port, pulse output, or up/down count select input
Read from timer	Count value can be read out by reading timer Ai register
Write to timer register	<ul style="list-style-type: none"> When counting stopped When a value is written to timer Ai register, it is written to both reload register and counter When counting in progress When a value is written to timer Ai register, it is written to only reload (Transferred to counter at next reload time)
Select function	<ul style="list-style-type: none"> Free-run count function Even when the timer overflows or underflows, the reload register content is not reloaded to it Pulse output function Each time the timer overflows or underflows, the TAIOUT pin's polarity is reversed

Note: This does not apply when the free-run function is selected.

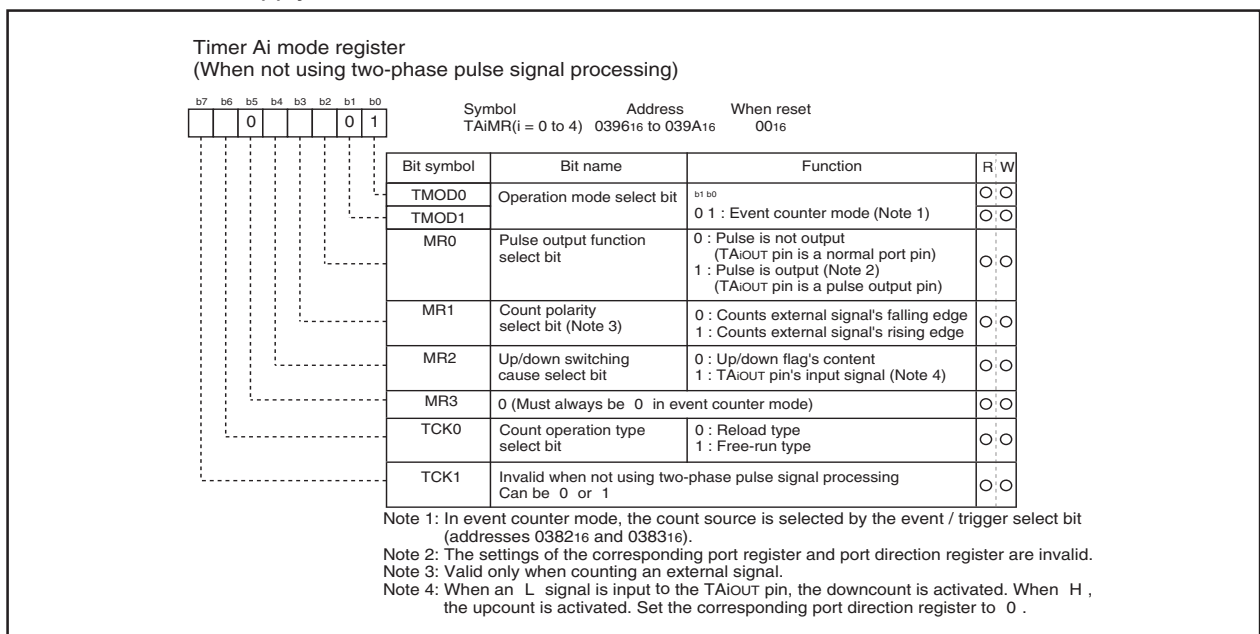
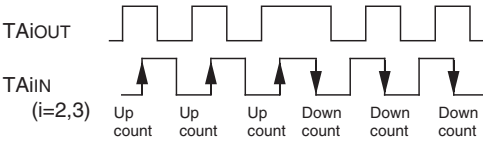
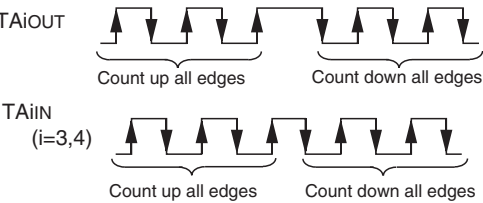

Figure 1.12.8. Timer Ai mode register in event counter mode

**Table 1.12.3. Timer specifications in event counter mode
(when processing two-phase pulse signal with timers A2, A3, and A4)**

Item	Specification
Count source	<ul style="list-style-type: none"> Two-phase pulse signals input to TAIiN or TAIiOUT pin
Count operation	<ul style="list-style-type: none"> Up count or down count can be selected by two-phase pulse signal When the timer overflows or underflows, the reload register content is reloaded and the timer starts over again (Note 1)
Divide ratio	$1 / (FFFF_{16} - n + 1)$ for up count $1 / (n + 1)$ for down count n : Set value
Count start condition	Count start flag is set (= 1)
Count stop condition	Count start flag is reset (= 0)
Interrupt request generation timing	Timer overflows or underflows
TAiIN pin function	Two-phase pulse input (Set the TAIiN pin correspondent port direction register to "0".)
TAiOUT pin function	Two-phase pulse input (Set the TAIiOUT pin correspondent port direction register to "0".)
Read from timer	Count value can be read out by reading timer A2, A3, or A4 register
Write to timer	<ul style="list-style-type: none"> When counting stopped When a value is written to timer A2, A3, or A4 register, it is written to both reload register and counter When counting in progress When a value is written to timer A2, A3, or A4 register, it is written to only reload register. (Transferred to counter at next reload time.)
Select function (Note 2)	<ul style="list-style-type: none"> Normal processing operation (timer A2 and timer A3) The timer counts up rising edges or counts down falling edges on the TAIiN pin when input signal on the TAIiOUT pin is "H".  <ul style="list-style-type: none"> Multiply-by-4 processing operation (timer A3 and timer A4) If the phase relationship is such that the TAIiN pin goes "H" when the input signal on the TAIiOUT pin is "H", the timer counts up rising and falling edges on the TAIiOUT and TAIiN pins. If the phase relationship is such that the TAIiN pin goes "L" when the input signal on the TAIiOUT pin is "H", the timer counts down rising and falling edges on the TAIiOUT and TAIiN pins. 

Note 1: This does not apply when the free-run function is selected.

Note 2: Timer A3 alone can be selected. Timer A2 is fixed to normal processing operation, and timer A4 is fixed to multiply-by-4 processing operation.

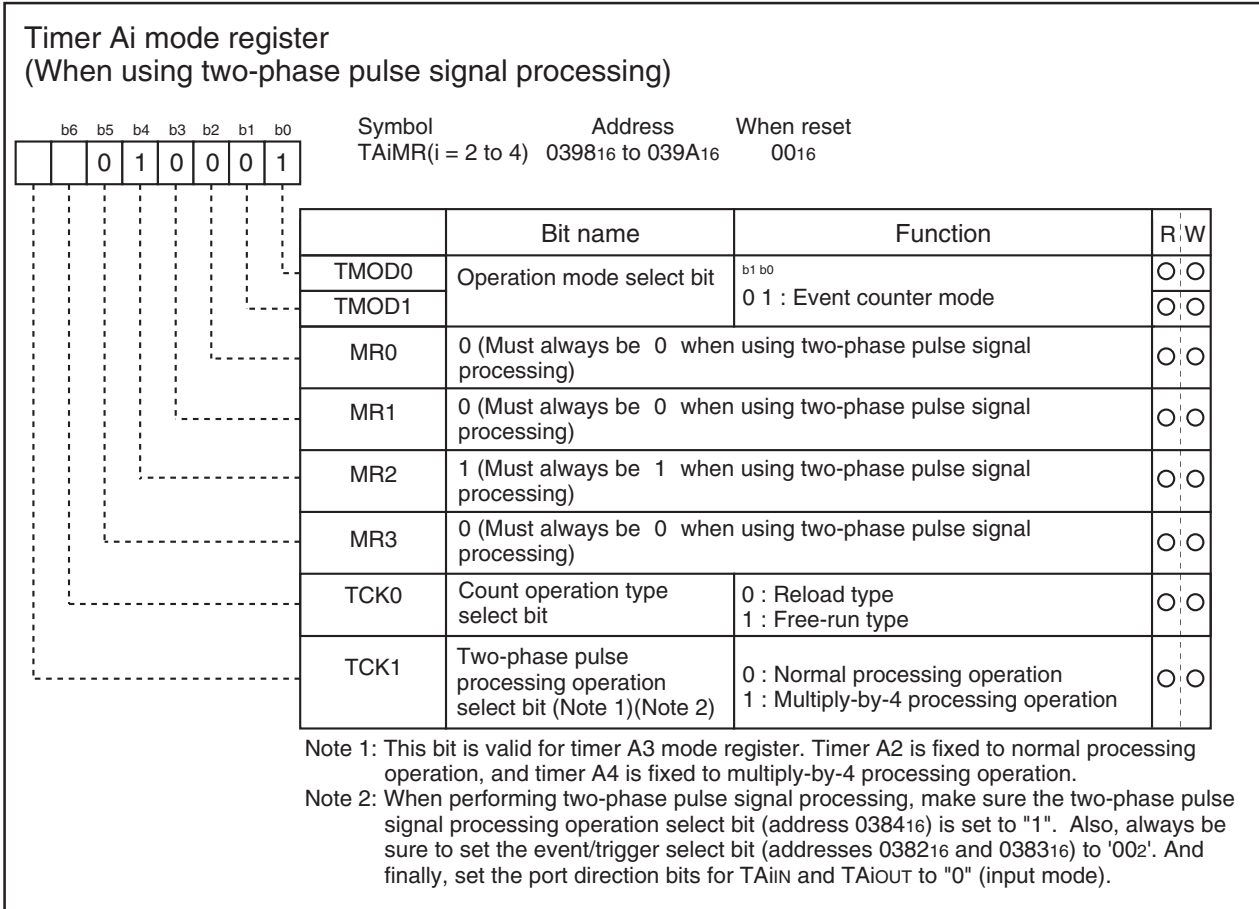

Figure 1.12.9. Timer Ai mode register in event counter mode

(3) One-shot timer mode

In this mode, the timer operates only once. (See Table 1.12.4.) When a trigger occurs, the timer starts up and continues operating for a given period. Figure 1.12.12 shows the timer Ai mode register in one-shot timer mode.

Table 1.12.4. Timer specifications in one-shot timer mode

Item	Specification
Count source	f1, f2, f8, f32, fC32
Count operation	<ul style="list-style-type: none"> The timer counts down When the count reaches 0000₁₆, the timer stops counting after reloading a new count If a trigger occurs when counting, the timer reloads a new count and restarts counting
Divide ratio	1/n n : Set value
Count start condition	<ul style="list-style-type: none"> An external trigger is input The timer overflows The one-shot start flag is set (= 1)
Count stop condition	<ul style="list-style-type: none"> A new count is reloaded after the count has reached 0000₁₆ The count start flag is reset (= 0)
Interrupt request generation timing	The count reaches 0000 ₁₆
TAiIN pin function	Programmable I/O port or trigger input
TAiOUT pin function	Programmable I/O port or pulse output
Read from timer	When timer Ai register is read, it indicates an indeterminate value
Write to timer	<ul style="list-style-type: none"> When counting stopped When a value is written to timer Ai register, it is written to both reload register and counter When counting in progress When a value is written to timer Ai register, it is written to only reload register (Transferred to counter at next reload time)

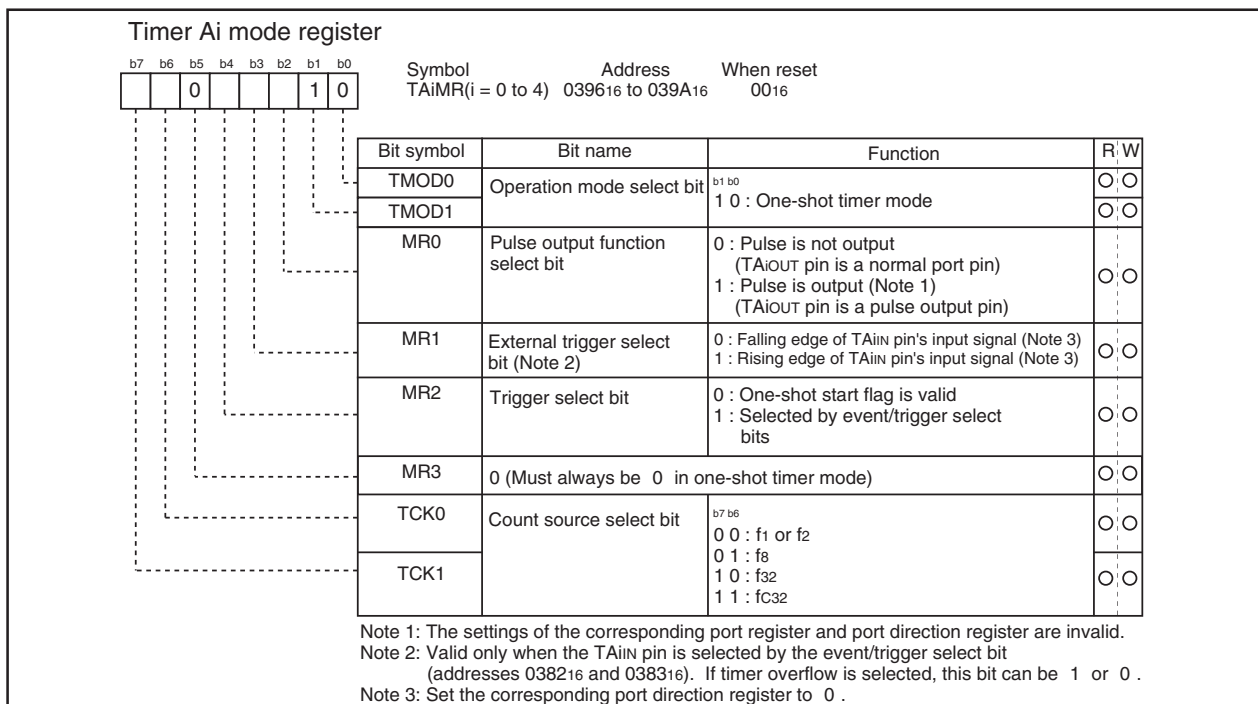

Figure 1.12.12. Timer Ai mode register in one-shot timer mode

(4) Pulse width modulation (PWM) mode

In this mode, the timer outputs pulses of a given width in succession. (See Table 1.12.5.) In this mode, the counter functions as either a 16-bit pulse width modulator or an 8-bit pulse width modulator. Figure 1.12.13 shows the timer Ai mode register in pulse width modulation mode. Figure 1.12.14 shows the example of how a 16-bit pulse width modulator operates. Figure 1.12.15 shows the example of how an 8-bit pulse width modulator operates.

Table 1.12.5. Timer specifications in pulse width modulation mode

Item	Specification
Count source	f1, f2, f8, f32, fc32
Count operation	<ul style="list-style-type: none"> The timer counts down (operating as an 8-bit or a 16-bit pulse width modulator) The timer reloads a new count at a rising edge of PWM pulse and continues counting The timer is not affected by a trigger that occurs when counting
16-bit PWM	High level width n / f_i n : Set value • Cycle time $(2^{16}-1) / f_i$ fixed
8-bit PWM	High level width $\times n (m+1) / f_i$ n : values set to timer Ai register's high-order address • Cycle time $(2^8-1) \times (m+1) / f_i$ m : values set to timer Ai register's low-order address
Count start condition	<ul style="list-style-type: none"> External trigger is input The timer overflows The count start flag is set (= 1)
Count stop condition	<ul style="list-style-type: none"> The count start flag is reset (= 0)
Interrupt request generation timing	PWM pulse goes "L"
TAiIN pin function	Programmable I/O port or trigger input
TAiOUT pin function	Pulse output
Read from timer	When timer Ai register is read, it indicates an indeterminate value
Write to timer	<ul style="list-style-type: none"> When counting stopped When a value is written to timer Ai register, it is written to both reload register and counter When counting in progress When a value is written to timer Ai register, it is written to only reload register (Transferred to counter at next reload time)

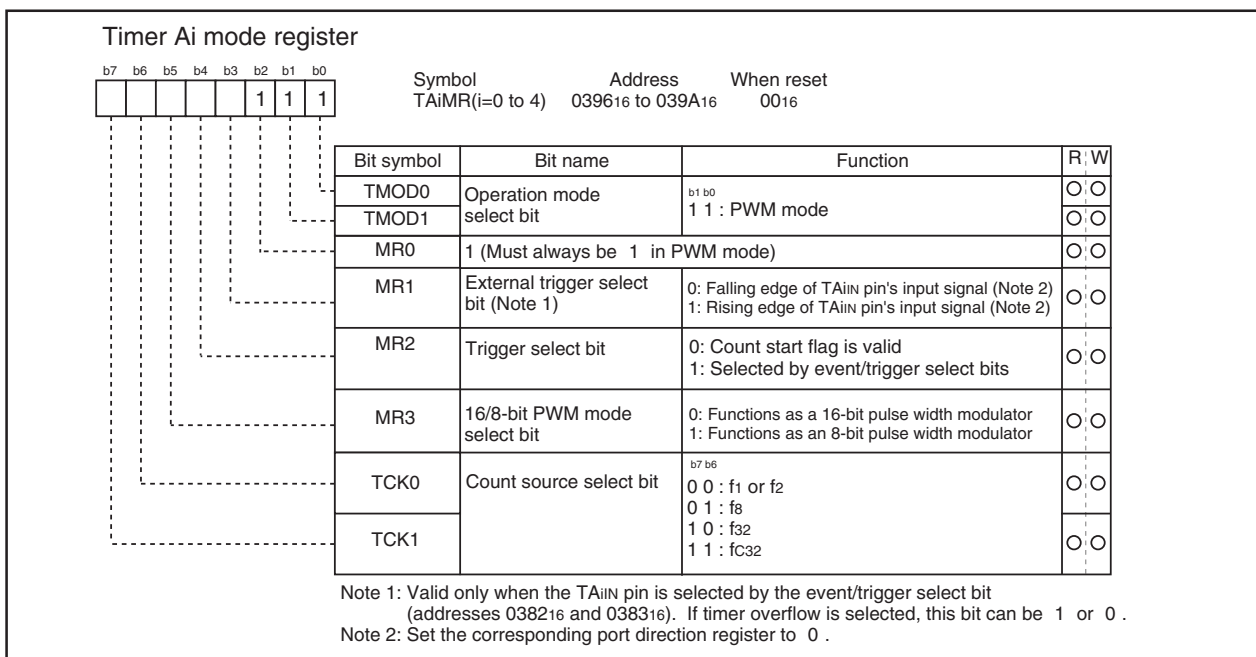

Figure 1.12.13. Timer Ai mode register in pulse width modulation mode

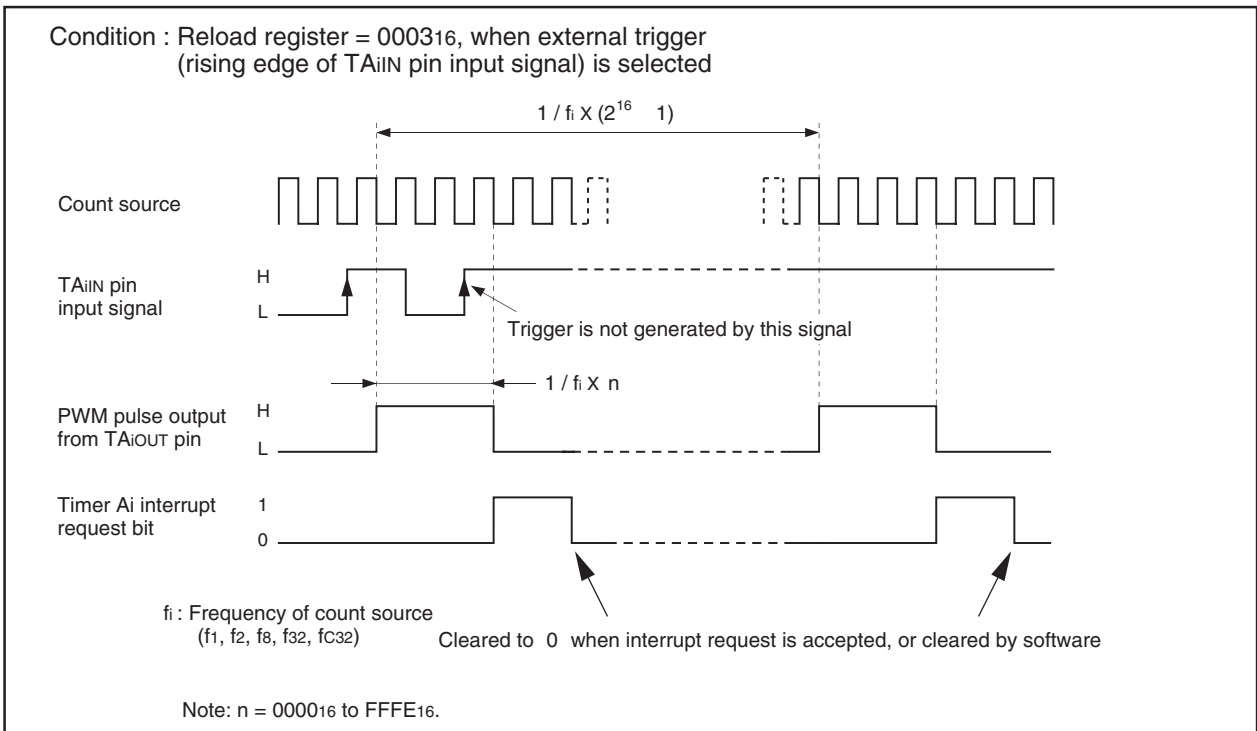

Figure 1.12.14. Example of how a 16-bit pulse width modulator operates

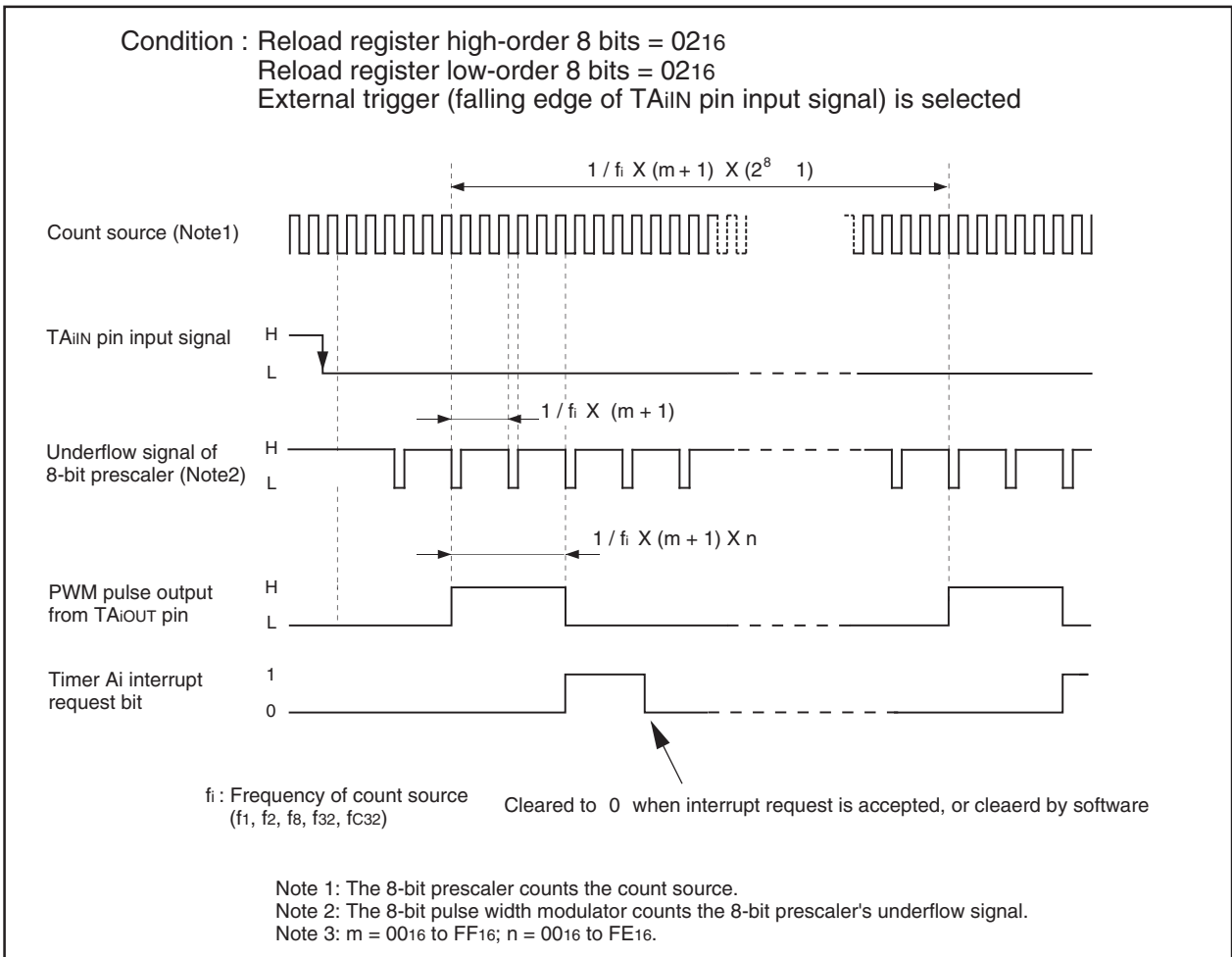

Figure 1.12.15. Example of how an 8-bit pulse width modulator operates

Timer B

Figure 1.13.16 shows the block diagram of timer B. Figures 1.13.17 and 1.13.18 show the timer B-related registers.

Use the timer Bi mode register (i = 0 to 2) bits 0 and 1 to choose the desired mode.

Timer B has three operation modes listed as follows:

- Timer mode: The timer counts an internal count source.
- Event counter mode: The timer counts pulses from an external source or a timer overflow.
- Pulse period/pulse width measuring mode: The timer measures an external signal's pulse period or pulse width.

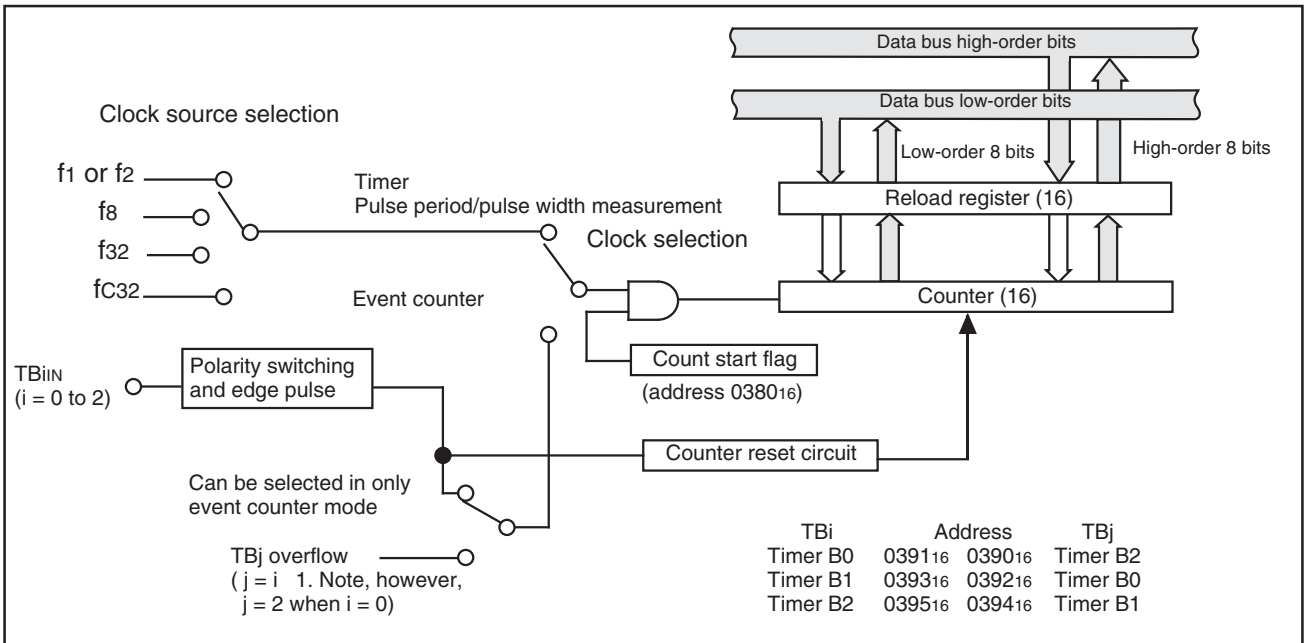

Figure 1.13.16. Block diagram of timer B

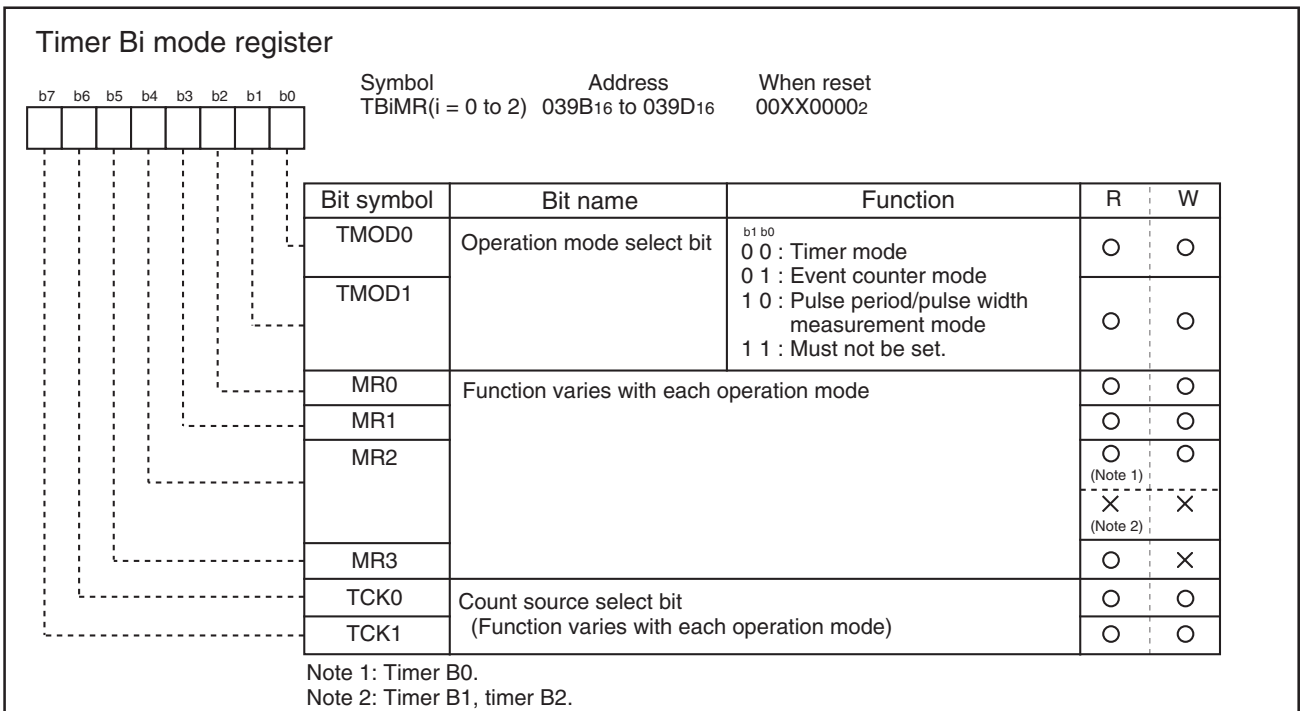

Figure 1.13.17. Timer B-related registers (1)

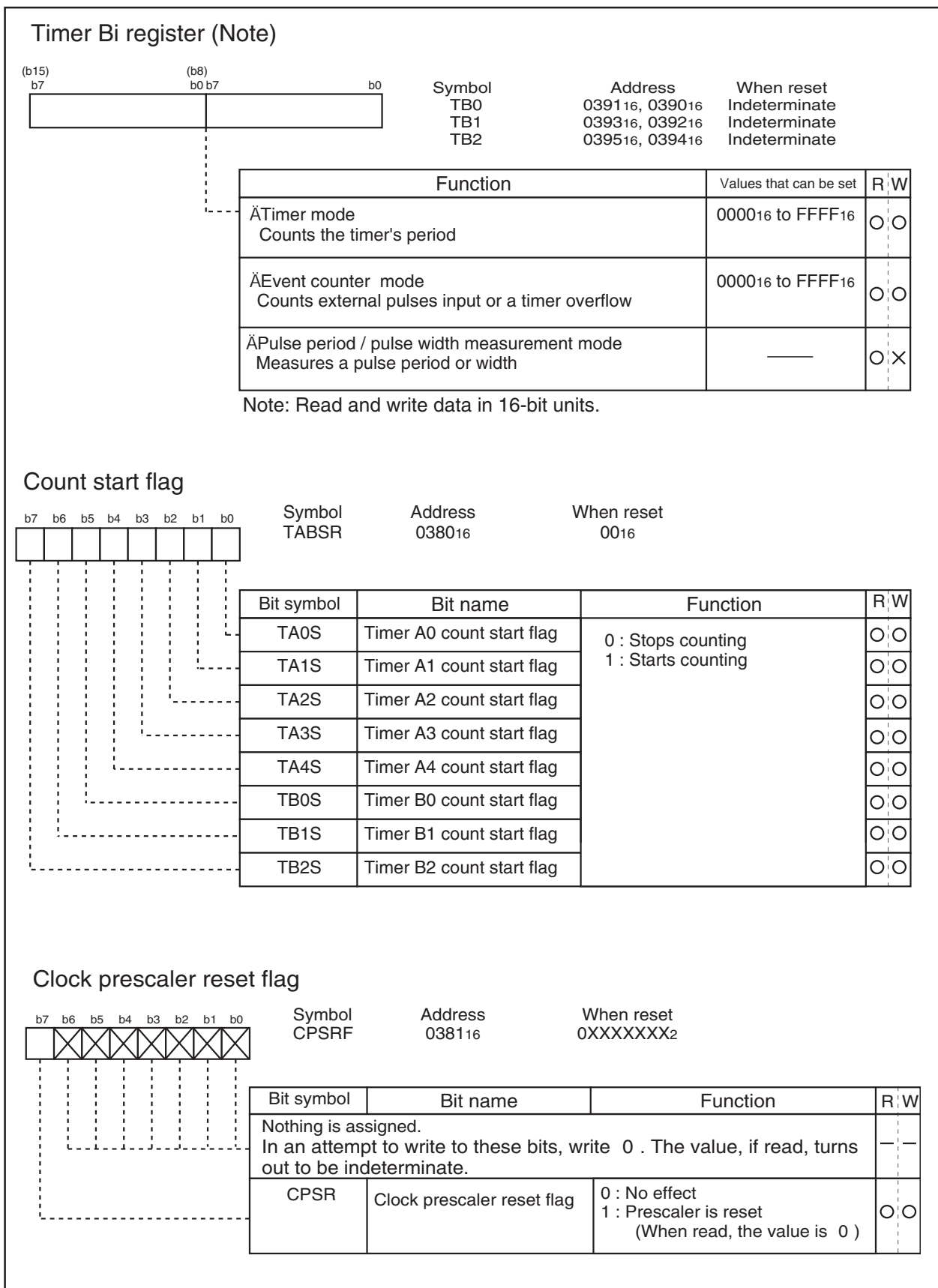

Figure 1.13.18. Timer B-related registers (2)

(1) Timer mode

In this mode, the timer counts an internally generated count source. (See Table 1.13.6.) Figure 1.13.19 shows the timer Bi mode register in timer mode.

Table 1.13.6. Timer specifications in timer mode

Item	Specification
Count source	f1, f8, f32, fC32
Count operation	<ul style="list-style-type: none"> Counts down When the timer underflows, it reloads the reload register contents before continuing counting
Divide ratio	1/(n+1) n : Set value
Count start condition	Count start flag is set (= 1)
Count stop condition	Count start flag is reset (= 0)
Interrupt request generation timing	The timer underflows
TBiIN pin function	Programmable I/O port
Read from timer	Count value is read out by reading timer Bi register
Write to timer	<ul style="list-style-type: none"> When counting stopped When a value is written to timer Bi register, it is written to both reload register and counter When counting in progress When a value is written to timer Bi register, it is written to only reload register (Transferred to counter at next reload time)

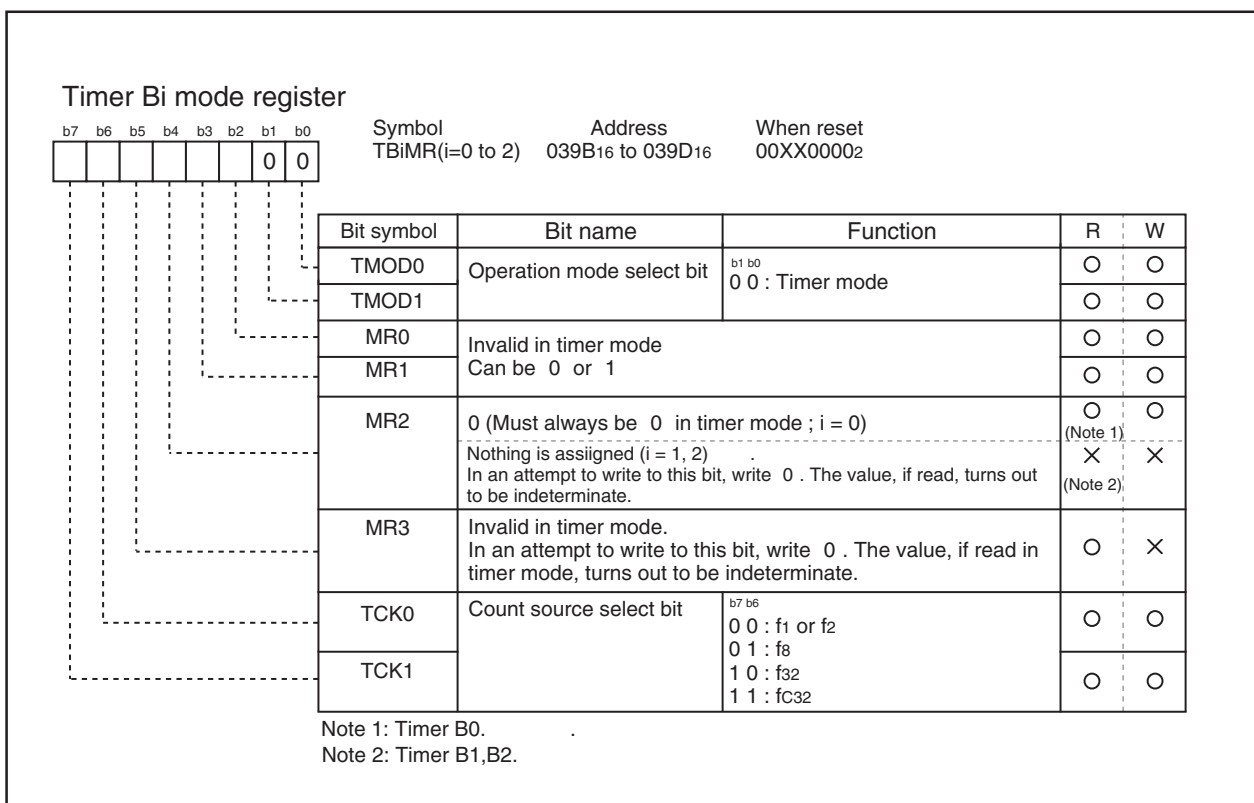
**Figure 1.13.19. Timer Bi mode register in timer mode**

(2) Event counter mode

In this mode, the timer counts an external signal or an internal timer's overflow. (See Table 1.13.7.)

Figure 1.13.20 shows the timer Bi mode register in event counter mode.

Table 1.13.7. Timer specifications in event counter mode

Item	Specification
Count source	<ul style="list-style-type: none"> External signals input to TBiIN pin Effective edge of count source can be a rising edge, a falling edge, or falling and rising edges as selected by software
Count operation	<ul style="list-style-type: none"> Counts down When the timer underflows, it reloads the reload register contents before continuing counting
Divide ratio	$1/(n+1)$ n : Set value
Count start condition	Count start flag is set (= 1)
Count stop condition	Count start flag is reset (= 0)
Interrupt request generation timing	The timer underflows
TBiIN pin function	Count source input
Read from timer	Count value can be read out by reading timer Bi register
Write to timer	<ul style="list-style-type: none"> When counting stopped When a value is written to timer Bi register, it is written to both reload register and counter When counting in progress When a value is written to timer Bi register, it is written to only reload register (Transferred to counter at next reload time)

Timer Bi mode register		Symbol	Address	When reset
		TBiMR(i=0 to 2)	039B ₁₆ to 039D ₁₆	00XX0000 ₂
Bit symbol	Bit name	Function	R	W
TMOD0		Operation mode select bit b ₁ b ₀ 0 1 : Event counter mode	○	○
TMOD1			○	○
MR0	Count polarity select bit (Note 1)	b ₃ b ₂ 0 0 : Counts external signal's falling edges 0 1 : Counts external signal's rising edges 1 0 : Counts external signal's falling and rising edges 1 1 : Must not be set.	○	○
MR1			○	○
MR2			0 (Must always be 0 in event counter mode; i = 0) Nothing is assigned (i = 1, 2) In an attempt to write to this bit, write 0. The value, if read, turns out to be indeterminate.	○ (Note 2)
MR3	Invalid in event counter mode. In an attempt to write to this bit, write 0. The value, if read in event counter mode, turns out to be indeterminate.		×	×
TCK0	Invalid in event counter mode. Can be 0 or 1.		○	○
TCK1	Event clock select	0 : Input from TBiIN pin (Note 4) 1 : T Bj overflow (j = i - 1; however, j = 2 when i = 0)	○	○

Note 1: Valid only when input from the TBiIN pin is selected as the event clock. If timer's overflow is selected, this bit can be 0 or 1.

Note 2: Timer B0.

Note 3: Timer B1, timer B2.

Note 4: Set the corresponding port direction register to 0.

Figure 1.13.20. Timer Bi mode register in event counter mode

(3) Pulse period/pulse width measurement mode

In this mode, the timer measures the pulse period or pulse width of an external signal. (See Table 1.13.8.) Figure 1.13.21 shows the timer Bi mode register in pulse period/pulse width measurement mode. Figure 1.13.22 shows the operation timing when measuring a pulse period. Figure 1.13.23 shows the operation timing when measuring a pulse width.

Table 1.13.8. Timer specifications in pulse period/pulse width measurement mode

Item	Specification
Count source	f1, f2, f8, f32, fc32
Count operation	<ul style="list-style-type: none"> • Up count • Counter value "0000₁₆" is transferred to reload register at measurement pulse's effective edge and the timer continues counting
Count start condition	Count start flag is set (= 1)
Count stop condition	Count start flag is reset (= 0)
Interrupt request generation timing	<ul style="list-style-type: none"> • When measurement pulse's effective edge is input (Note 1) • When an overflow occurs. (Simultaneously, the timer Bi overflow flag changes to "1". Assume that the count start flag condition is "1" and then the timer Bi overflow flag becomes "1". If the timer Bi mode register has a write-access after next count cycle of the timer from the above condition, the timer Bi overflow flag becomes "0".)
TBiIN pin function	Measurement pulse input
Read from timer	When timer Bi register is read, it indicates the reload register's content (measurement result) (Note 2)
Write to timer	Cannot be written to

Note 1: An interrupt request is not generated when the first effective edge is input after the timer has started counting.

Note 2: The value read out from the timer Bi register is indeterminate until the second effective edge is input after the timer has started counting.

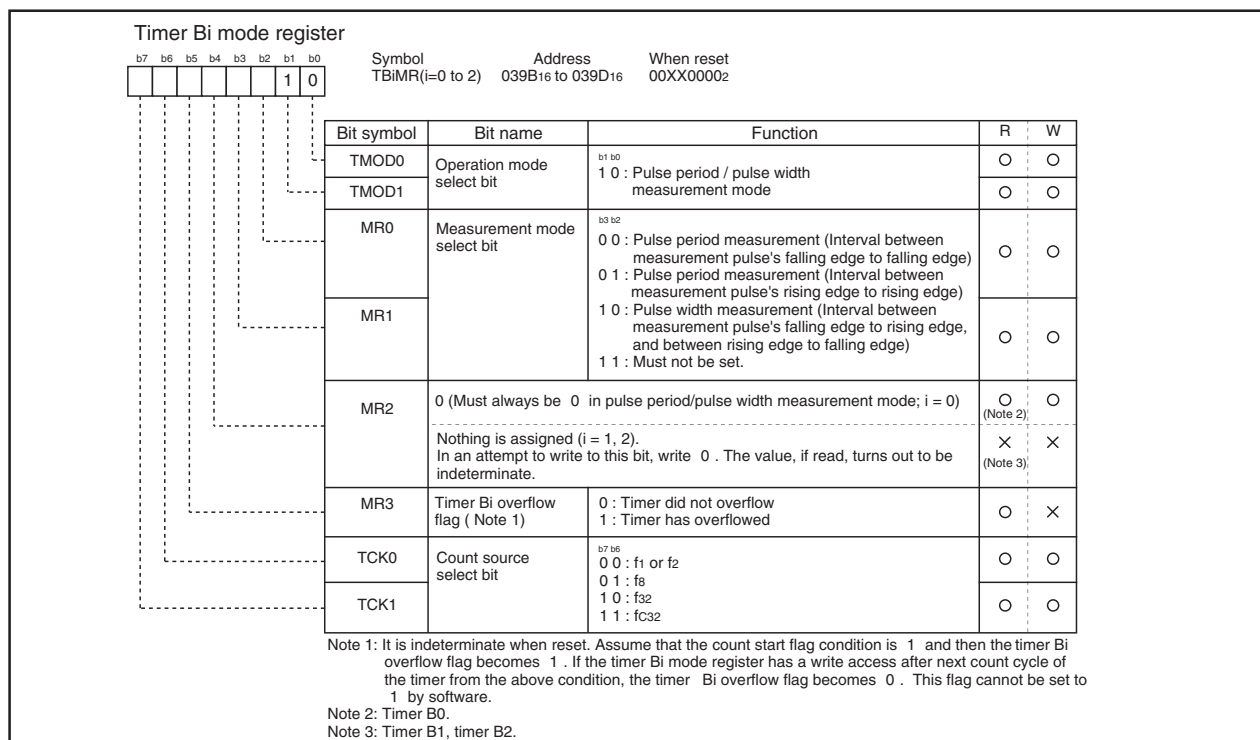

Figure 1.13.21. Timer Bi mode register in pulse period/pulse width measurement mode

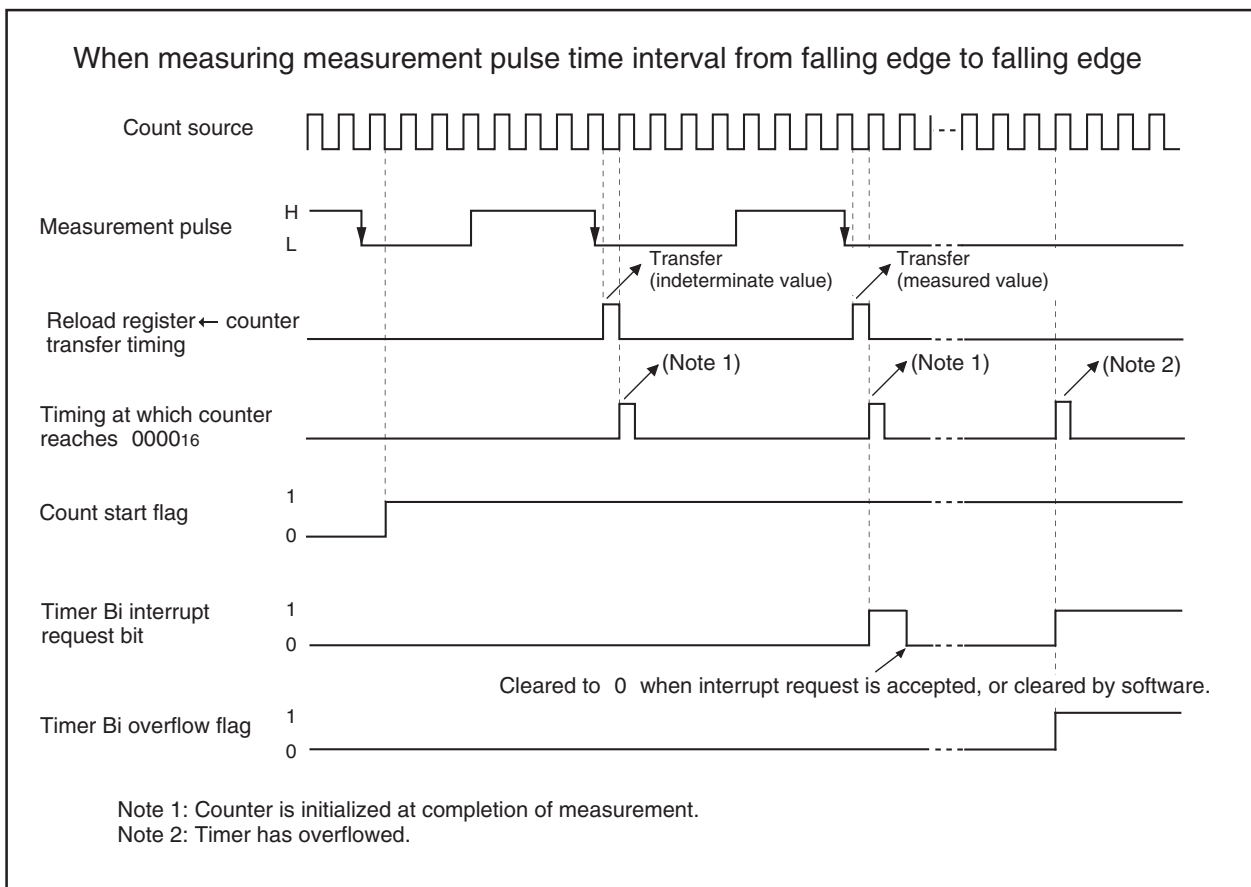

Figure 1.13.22. Operation timing when measuring a pulse period

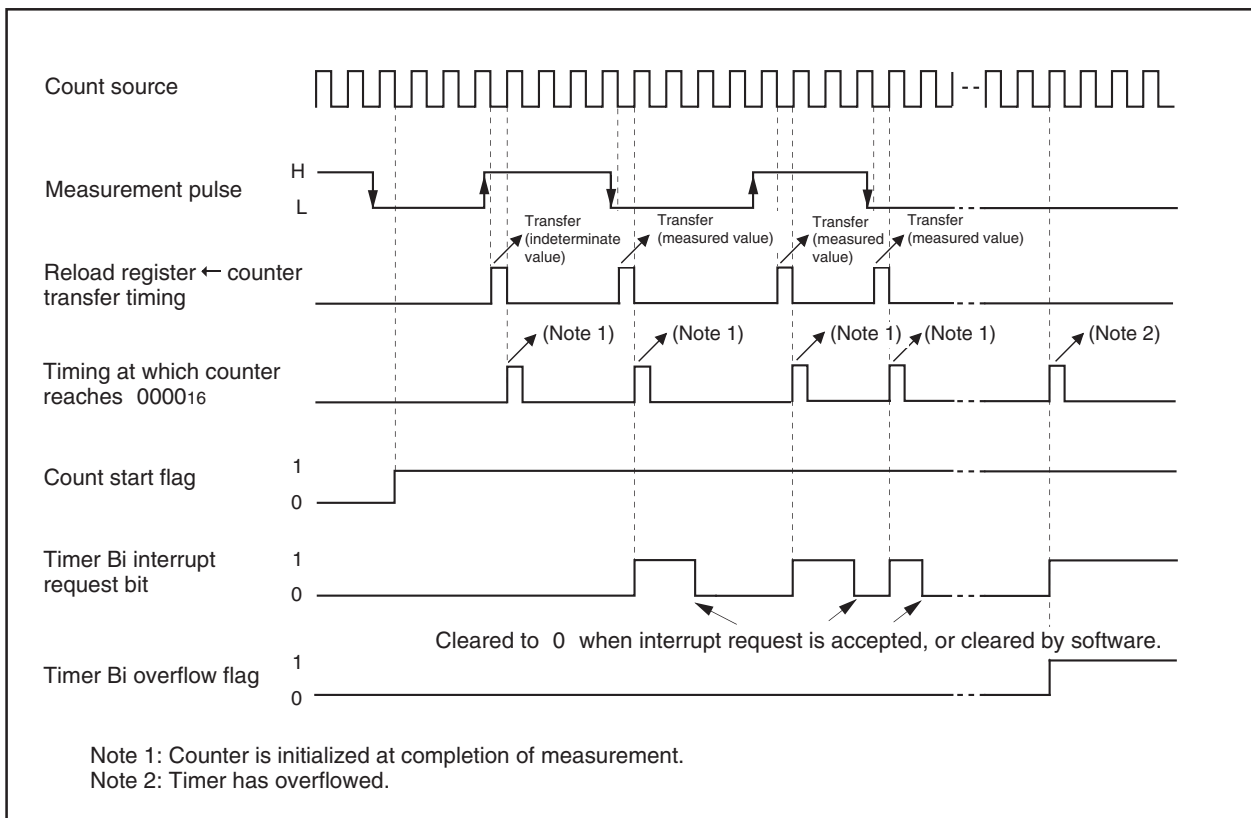

Figure 1.13.23. Operation timing when measuring a pulse width

Three-Phase Motor Control Timer Function

Use of more than one built-in timer A and timer B provides the means of outputting three-phase motor driving waveforms. This function requires that P85 become \overline{SD} , making it important that P85 not be used for general purpose I/O (GPIO). If the \overline{SD} feature is not needed, then P85/ \overline{SD} must always be driven high.

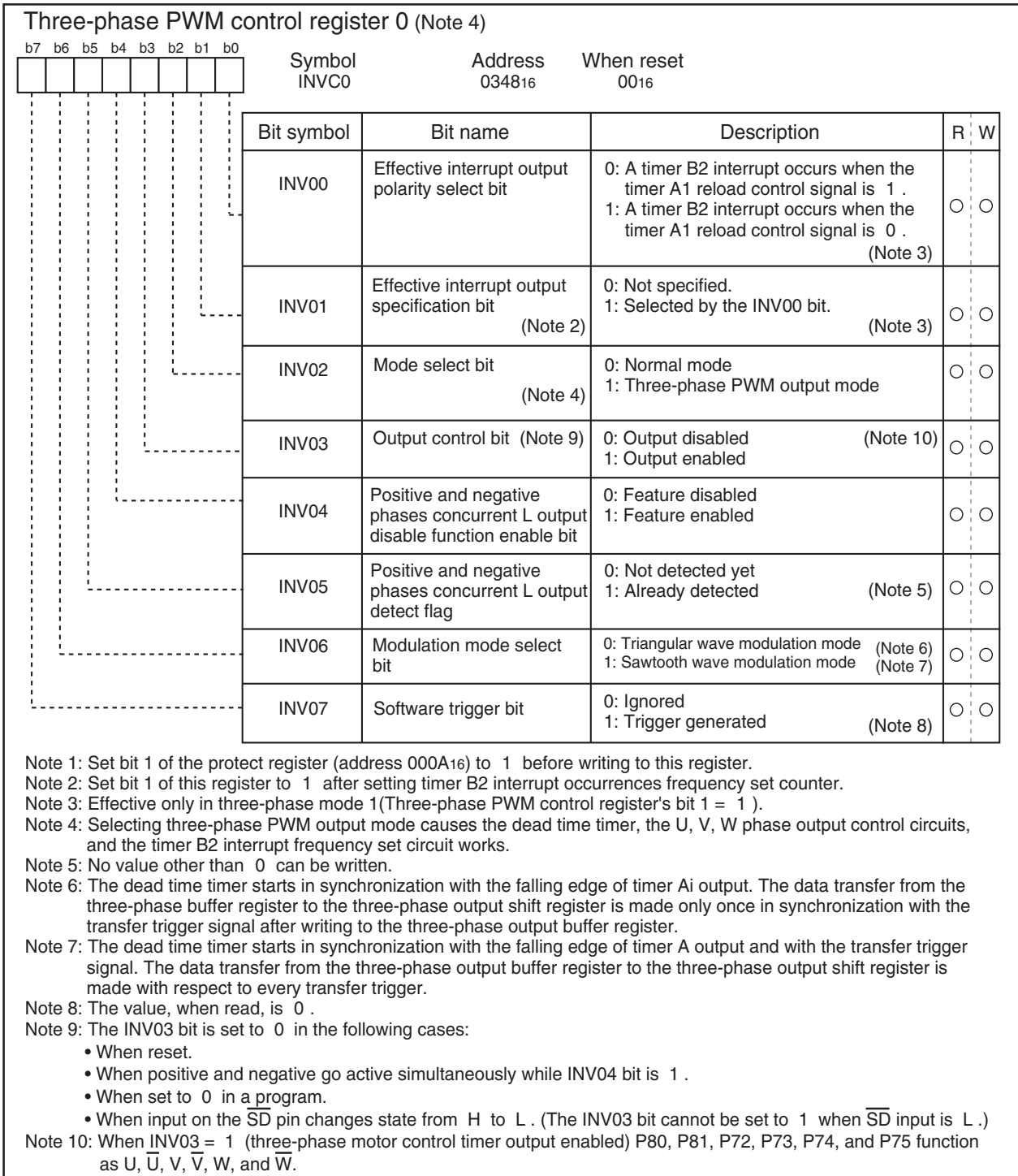

Figure 1.14.1. Registers related to timers for three-phase motor control (1)

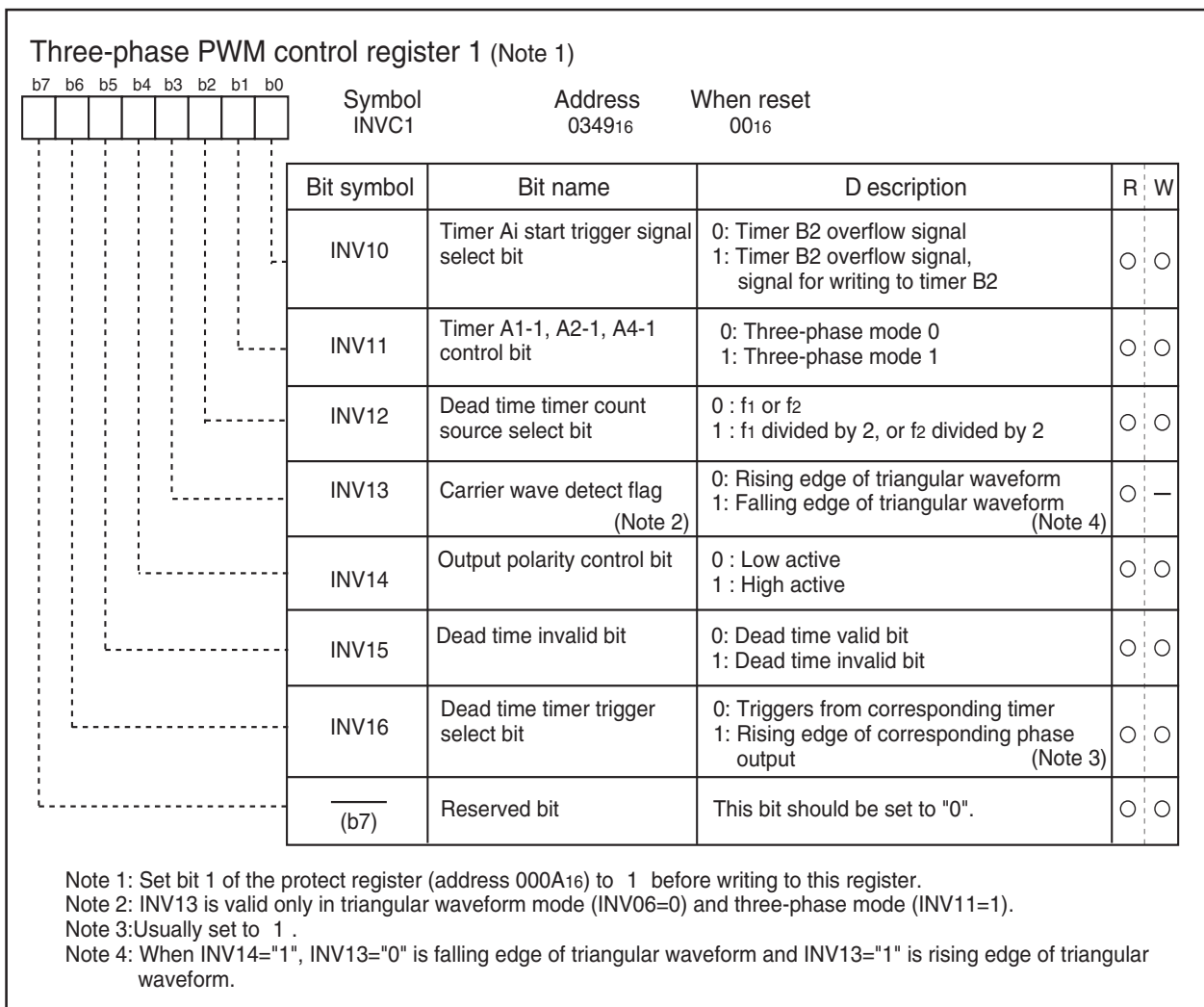

Figure 1.14.2. Registers related to timers for three-phase motor control (2)

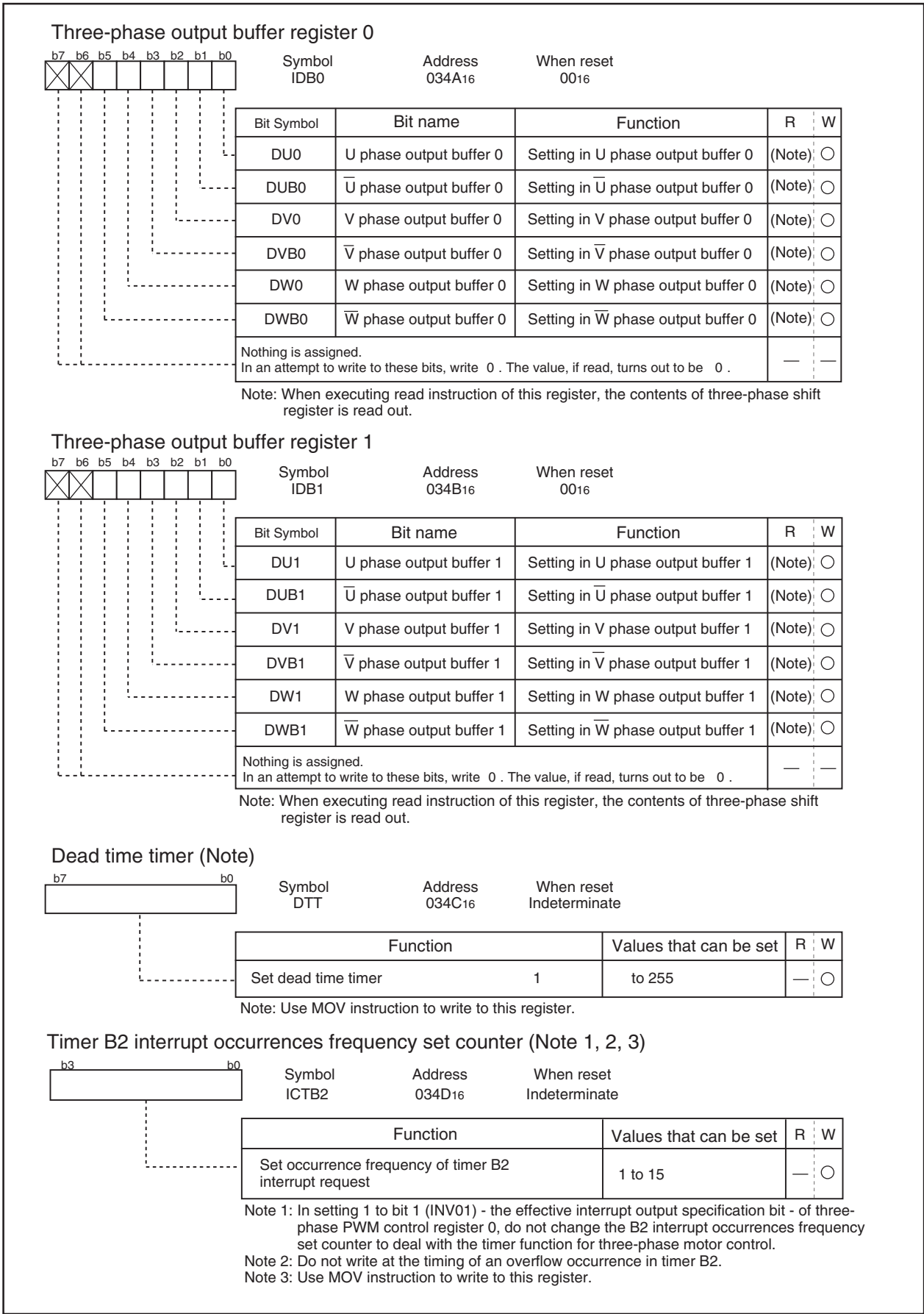

Figure 1.14.3. Registers related to timers for three-phase motor control (3)

Timer Ai (i=1, 2, 4) register (Notes 1, 4)

(b15) b7	(b8) b0 b7	b0	Symbol	Address	When reset
[Register Diagram]			TA1	0389 ₁₆ ,0388 ₁₆	Indeterminate
			TA2	038B ₁₆ ,038A ₁₆	Indeterminate
			TA4	038F ₁₆ ,038E ₁₆	Indeterminate

Function	Values that can be set	R	W
· Timer mode Counts an internal count source	0000 ₁₆ to FFFF ₁₆	○	○
· One-shot timer mode Counts a one shot width	0000 ₁₆ to FFFF ₁₆ (Note 2, 3)	×	○

Note 1: Read and write data in 16-bit units.
 Note 2: When the timer Ai register is set to "0000₁₆", the counter does not operate and a timer Ai interrupt does not occur.
 Note 3: Use MOV instruction to write to this register.
 Note 4: Do not write to these registers synchronously with a timer B2 underflow.

Timer Ai-1 (i=1, 2, 4) register (Notes 1, 2)

(b15) b7	(b8) b0 b7	b0	Symbol	Address	When reset
[Register Diagram]			TA11	0343 ₁₆ ,0342 ₁₆	Indeterminate
			TA21	0345 ₁₆ ,0344 ₁₆	Indeterminate
			TA41	0347 ₁₆ ,0346 ₁₆	Indeterminate

Function	Values that can be set	R	W
Counts an internal count source	0000 ₁₆ to FFFF ₁₆	○	○

Note 1: Read and write data in 16-bit units.
 Note 2: Do not write to these registers synchronously with a timer B2 underflow.

Timer B2 special mode register

b7	b6	b5	b4	b3	b2	b1	b0	Symbol	Address	When reset
×	×	×	×	×	×	×	×	TB2SC	039E ₁₆	XXXXXX00 ₂

Bit symbol	Bit name	Function	R	W
PWCOM	Timer B2 reload timing switching bit	0 : Next underflow 1 : Synchronized rising edge of triangular wave	○	○
IVPCR1	Three phase output port SD control bit 1 (Note 1,2,3)	0 : \overline{SD} pin input port Hi-z disabled 1 : SD pin input port Hi-z enabled	○	○
Nothing is assigned. When write, set 0 . When read, its content is 0 .			—	—

Note 1: Set the protect register (address 000A₁₆) to "1" before writing to this register.
 Note 2: Related pins are P80, P81, P72, P73, P74, and P75, regardless of function assigned.
 Note 3: Select P85 as input port prior to setting IVPCR1 to "1".

Figure 1.14.4. Registers related to timers for three-phase motor control (4)

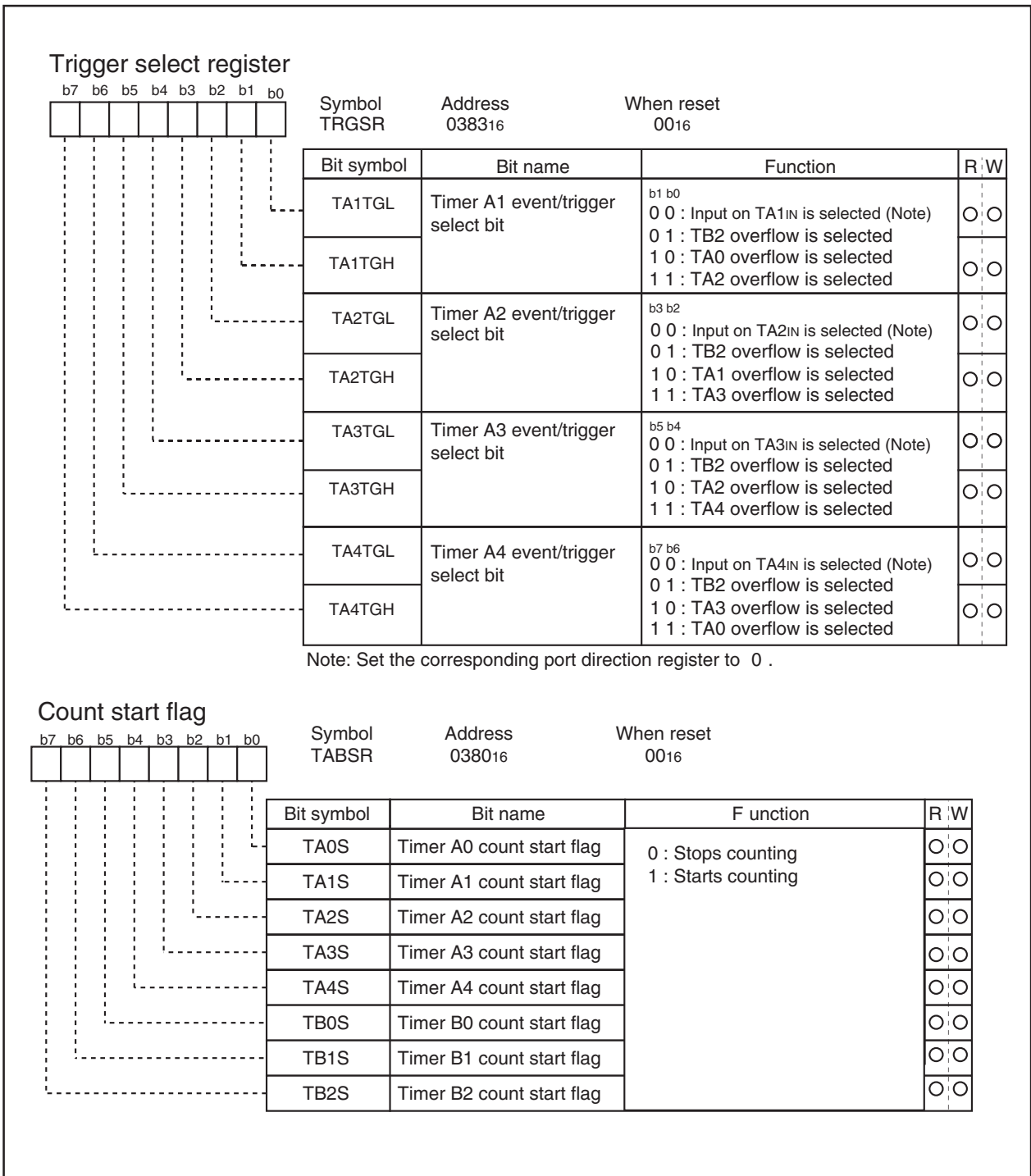

Figure 1.14.5. Registers related to timers for three-phase motor control (5)

Three-phase motor driving waveform output mode (three-phase PWM output mode)

Setting "1" in the mode select bit (bit 2 at 0348₁₆) shown in Figure 1.14.1 - causes three-phase PWM output mode that uses four timers A1, A2, A4, and B2 to be selected. As shown in Figure 1.14.6, set timers A1, A2, and A4 in one-shot timer mode, set the trigger in timer B2, and set timer B2 in timer mode using the respective timer mode registers.

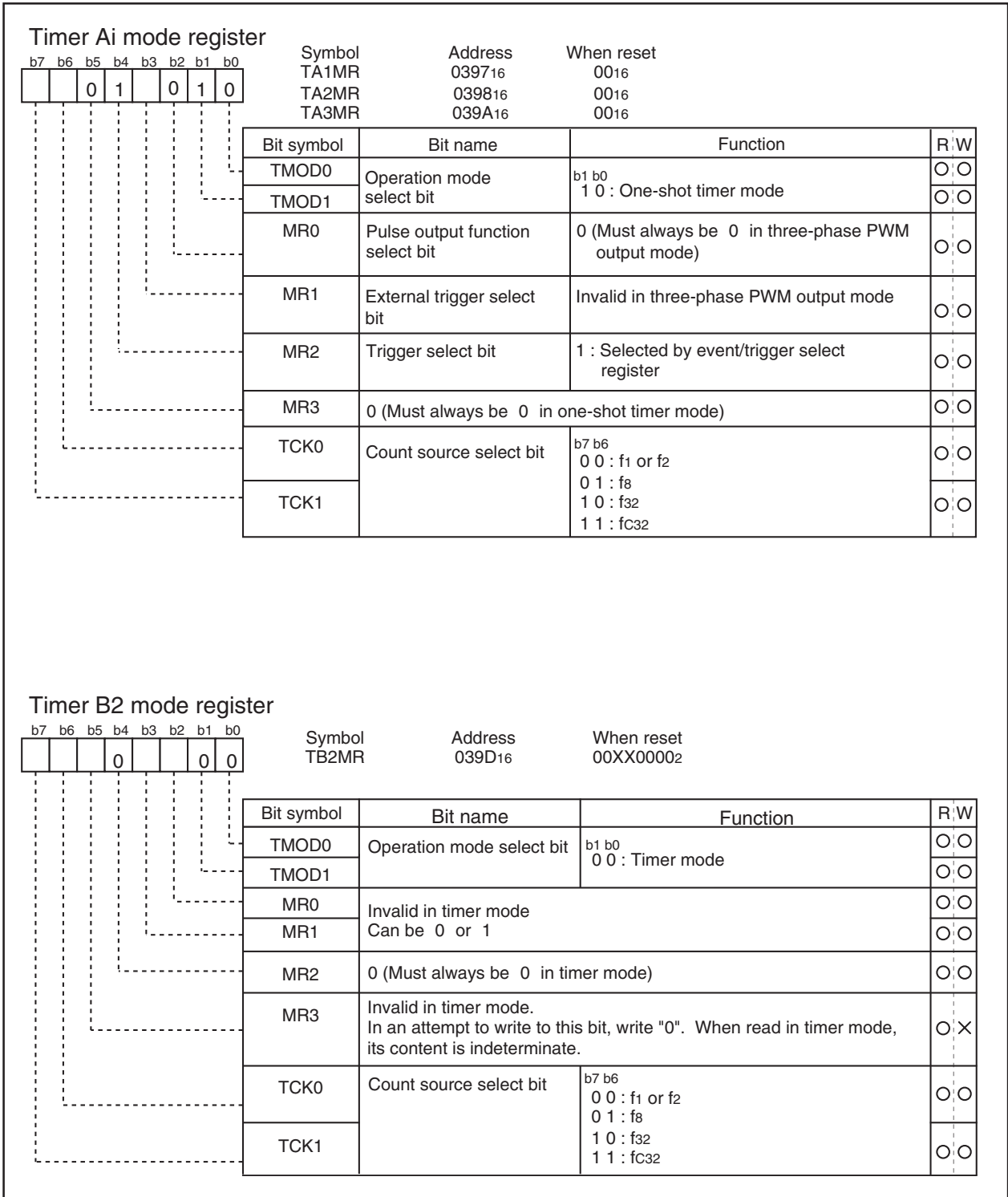

Figure 1.14.6. Timer mode registers in three-phase PWM output mode

Figure 1.14.7 shows the block diagram for three-phase PWM output mode. When selecting output polarity “L” active in three-phase PWM output mode, the positive-phase waveforms (U phase, V phase, and W phase) and negative waveforms (U phase, V phase, and W phase), six waveforms in total, are output from P80, P81, P72, P73, P74, and P75 as active on the “L” level. Of the timers used in this mode, timer A4 controls the U phase and U phase, timer A1 controls the V phase and V phase, and timer A2 controls the W phase and W phase respectively; timer B2 controls the periods of one-shot pulse output from timers A4, A1, and A2.

In outputting a waveform, dead time can be set so as to cause the “L” level of the positive waveform output (U phase, V phase, and W phase) not to lap over the “L” level of the negative waveform output (U phase, V phase, and W phase).

To set short circuit time, use three 8-bit timers sharing the reload register for setting dead time. A value from 1 through 255 can be set as the count of the timer for setting dead time. The timer for setting dead time works as a one-shot timer. If a value is written to the dead time timer (034C₁₆), the value is written to the reload register shared by the three timers for setting dead time.

Any of the timers for setting dead time takes the value of the reload register into its counter, if a start trigger comes from its corresponding timer, and performs a down count in line with the clock source selected by the dead time timer count source select bit (bit 2 at 0349₁₆). The timer can receive another trigger again before the workings due to the previous trigger are completed. In this instance, the timer performs a down count from the reload register’s content after its transfer, provoked by the trigger, to the timer for setting dead time.

Since the timer for setting dead time works as a one-shot timer, it starts outputting pulses if a trigger comes; it stops outputting pulses as soon as its content becomes 00₁₆, and waits for the next trigger to come.

The positive waveforms (U phase, V phase, and W phase) and the negative waveforms (U phase, V phase, and W phase) in three-phase PWM output mode are output from respective ports by means of setting “1” in the output control bit (bit 3 at 0348₁₆). Setting “0” in this bit causes the ports to be the state of set by port direction register. This bit can be set to “0” not only by use of the applicable instruction, but by entering a falling edge in the NMI terminal or by resetting. Also, if “1” is set in the positive and negative phases concurrent L output disable function enable bit (bit 4 at 0348₁₆) causes one of the pairs of U phase and U phase, V phase and V phase, and W phase and W phase concurrently go to “L”, as a result, the port becomes the state of set by port direction register.

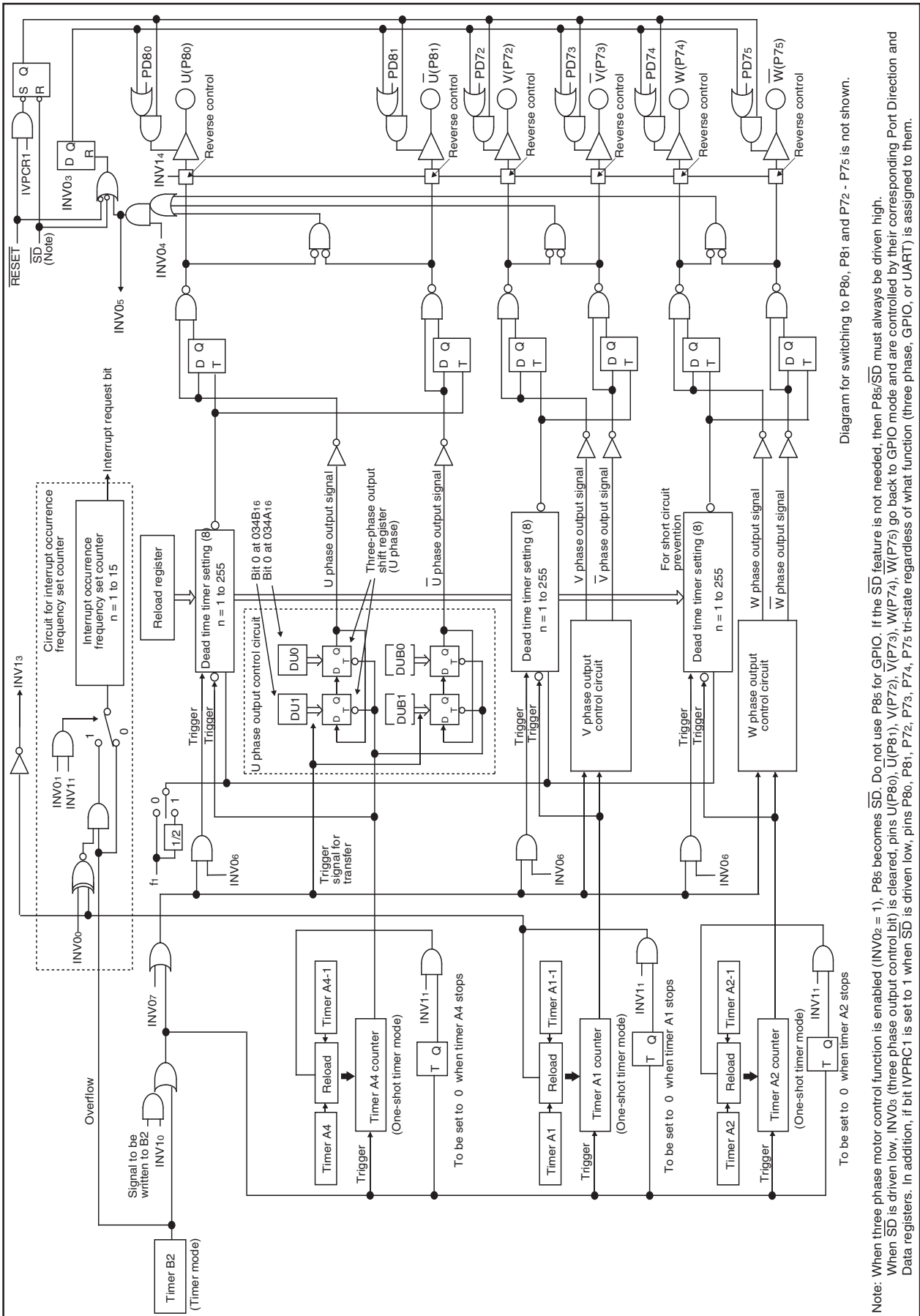

Diagram for switching to P80, P81 and P72 - P75 is not shown.

Note: When three phase motor control function is enabled (INV02 = 1), P85 becomes \bar{SD} . Do not use P85 for GPIO. If the \bar{SD} feature is not needed, then P85/ \bar{SD} must always be driven high. When \bar{SD} is driven low, INV0s (three phase output control bit) is cleared, pins U(P80), $\bar{U}(P81)$, V(P72), $\bar{V}(P73)$, W(P74), $\bar{W}(P75)$ go back to GPIO mode and are controlled by their corresponding Port Direction and Data registers. In addition, if bit IVPOR1 is set to 1 when \bar{SD} is driven low, pins P80, P81, P72, P73, P74, P75 tri-state regardless of what function (three phase, GPIO, or UART) is assigned to them.

Figure 1.14.7. Block diagram for three-phase PWM output mode

Triangular wave modulation

To generate a PWM waveform of triangular wave modulation, set “0” in the modulation mode select bit (bit 6 at 0348₁₆). Also, set “1” in the timers A4-1, A1-1, A2-1 control bit (bit 1 at 0349₁₆). In this mode, each of timers A4, A1, and A2 has two timer registers, and alternately reloads the timer register’s content to the counter every time timer B2 counter’s content becomes 0000₁₆. If “0” is set to the effective interrupt output specification bit (bit 1 at 0348₁₆), the frequency of interrupt requests that occur every time the timer B2 counter’s value becomes 0000₁₆ can be set by use of the timer B2 counter (034D₁₆) for setting the frequency of interrupt occurrences. The frequency of occurrences is given by (setting; setting • 0).

Setting “1” in the effective interrupt output specification bit (bit 1 at 0348₁₆) provides the means to choose which value of the timer A1 reload control signal to use, “0” or “1”, to cause timer B2’s interrupt request to occur. To make this selection, use the effective interrupt output polarity selection bit (bit 0 at 0348₁₆).

An example of U phase waveform is shown in Figure 1.14.8, and the description of waveform output workings is given below. Set “1” in DU0 (bit 0 at 034A₁₆). And set “0” in DUB0 (bit 1 at 034A₁₆). In addition, set “0” in DU1 (bit 0 at 034B₁₆) and set “1” in DUB1 (bit 1 at 034B₁₆). Also, set “0” in the effective interrupt output specification bit (bit 1 at 0348₁₆) to set a value in the timer B2 interrupt occurrence frequency set counter. By this setting, a timer B2 interrupt occurs when the timer B2 counter’s content becomes 0000₁₆ as many as (setting) times. Furthermore, set “1” in the effective interrupt output specification bit (bit 1 at 0348₁₆), set “0” in the effective interrupt output polarity select bit (bit 0 at 0348₁₆) and set “1” in the interrupt occurrence frequency set counter (034D₁₆). These settings cause a timer B2 interrupt to occur every other interval when the U phase output goes to “H”.

When the timer B2 counter’s content becomes 0000₁₆, timer A4 starts outputting one-shot pulses. In this instance, the content of DU1 (bit 0 at 034B₁₆) and that of DU0 (bit 0 at 034A₁₆) are set in the three-phase output shift register (U phase), the content of DUB1 (bit 1 at 034B₁₆) and that of DUB0 (bit 1 at 034A₁₆) are set in the three-phase output shift register (U phase). After triangular wave modulation mode is selected, however, no setting is made in the shift register even though the timer B2 counter’s content becomes 0000₁₆.

The value of DU0 and that of DUB0 are output to the U terminal (P80) and to the U terminal (P81) respectively. When the timer A4 counter counts the value written to timer A4 (038F₁₆, 038E₁₆) and when timer A4 finishes outputting one-shot pulses, the three-phase shift register’s content is shifted one position, and the value of DU1 and that of DUB1 are output to the U phase output signal and to U phase output signal respectively. At this time, one-shot pulses are output from the timer for setting dead time used for setting the time over which the “L” level of the U phase waveform does not lap over the “L” level of the U phase waveform, which has the opposite phase of the former. The U phase waveform output that started from the “H” level keeps its level until the timer for setting dead time finishes outputting one-shot pulses even though the three-phase output shift register’s content changes from “1” to “0” by the effect of the one-shot pulses. When the timer for setting dead time finishes outputting one-shot pulses, “0” already shifted in the three-phase shift register goes effective, and the U phase waveform changes to the “L” level. When the timer B2 counter’s content becomes 0000₁₆, the timer A4 counter starts counting the value written to timer A4-1 (0347₁₆, 0346₁₆), and starts outputting one-shot pulses. When timer A4 finishes outputting one-shot pulses, the three-phase shift register’s content is shifted one position, but if the three-phase output shift register’s content changes from “0” to “1” as a result of the shift, the output level changes from “L” to “H” without waiting for the timer for setting dead time to finish outputting one-shot pulses. A U phase waveform is generated by these workings repeatedly. With the exception that the three-phase output shift register on the U phase side is used, the workings in generating a U phase

waveform, which has the opposite phase of the U phase waveform, are the same as in generating a U phase waveform. In this way, a waveform can be picked up from the applicable terminal in a manner in which the "L" level of the U phase waveform doesn't lap over that of the U phase waveform, which has the opposite phase of the U phase waveform. The width of the "L" level too can be adjusted by varying the values of timer B2, timer A4, and timer A4-1. In dealing with the V and W phases, and V and W phases, the latter are of opposite phase of the former, have the corresponding timers work similarly to dealing with the U and U phases to generate an intended waveform.

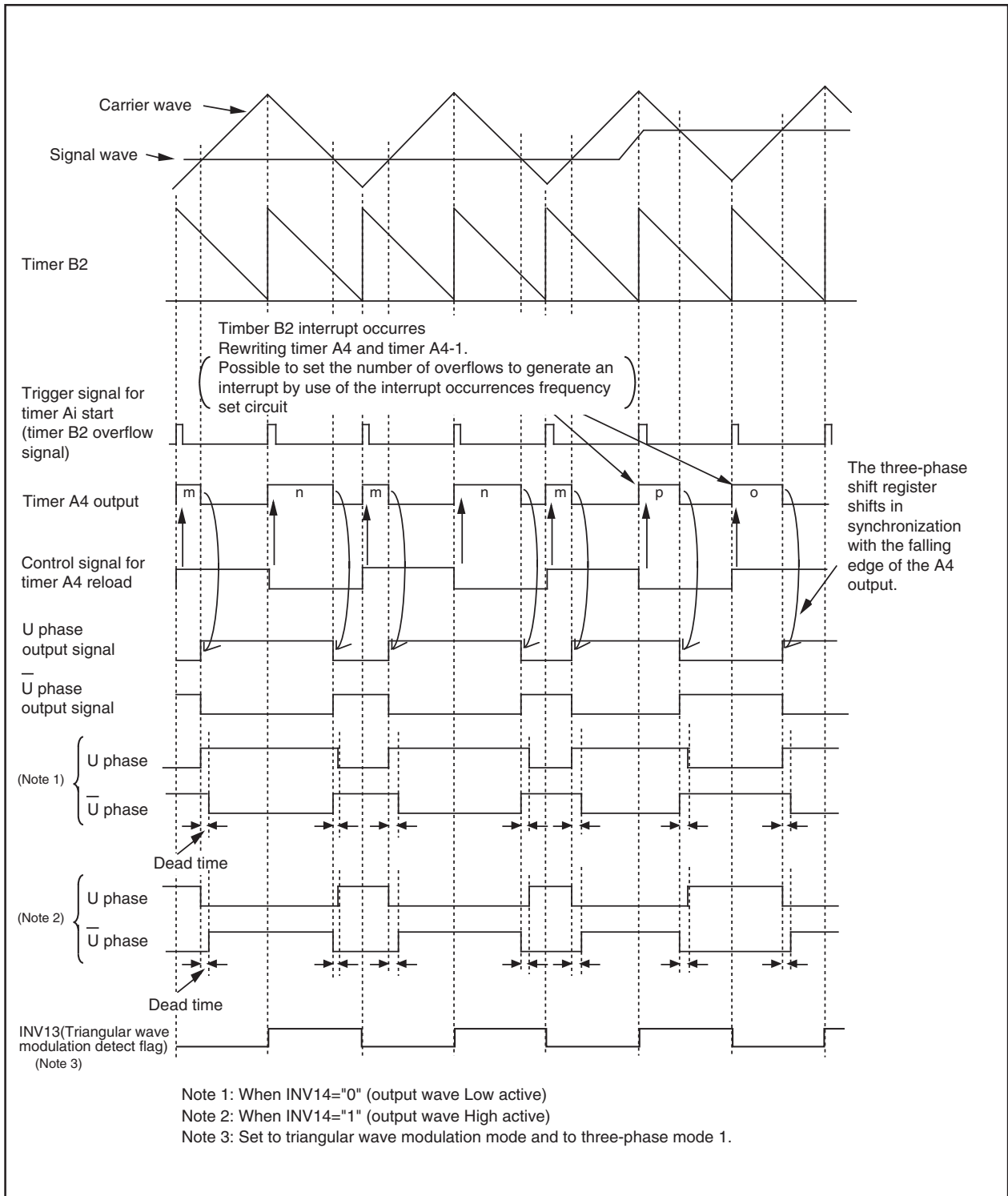

Figure 1.14.8. Timing chart of operation (1)

Assigning certain values to DU0 (bit 0 at 034A16) and DUB0 (bit 1 at 034A16), and to DU1 (bit 0 at 034B16) and DUB1 (bit 1 at 034B16) allows the user to output the waveforms as shown in Figure 1.14.9, that is, to output the U phase alone, to fix U phase to "H", to fix the U phase to "H," or to output the U phase alone.

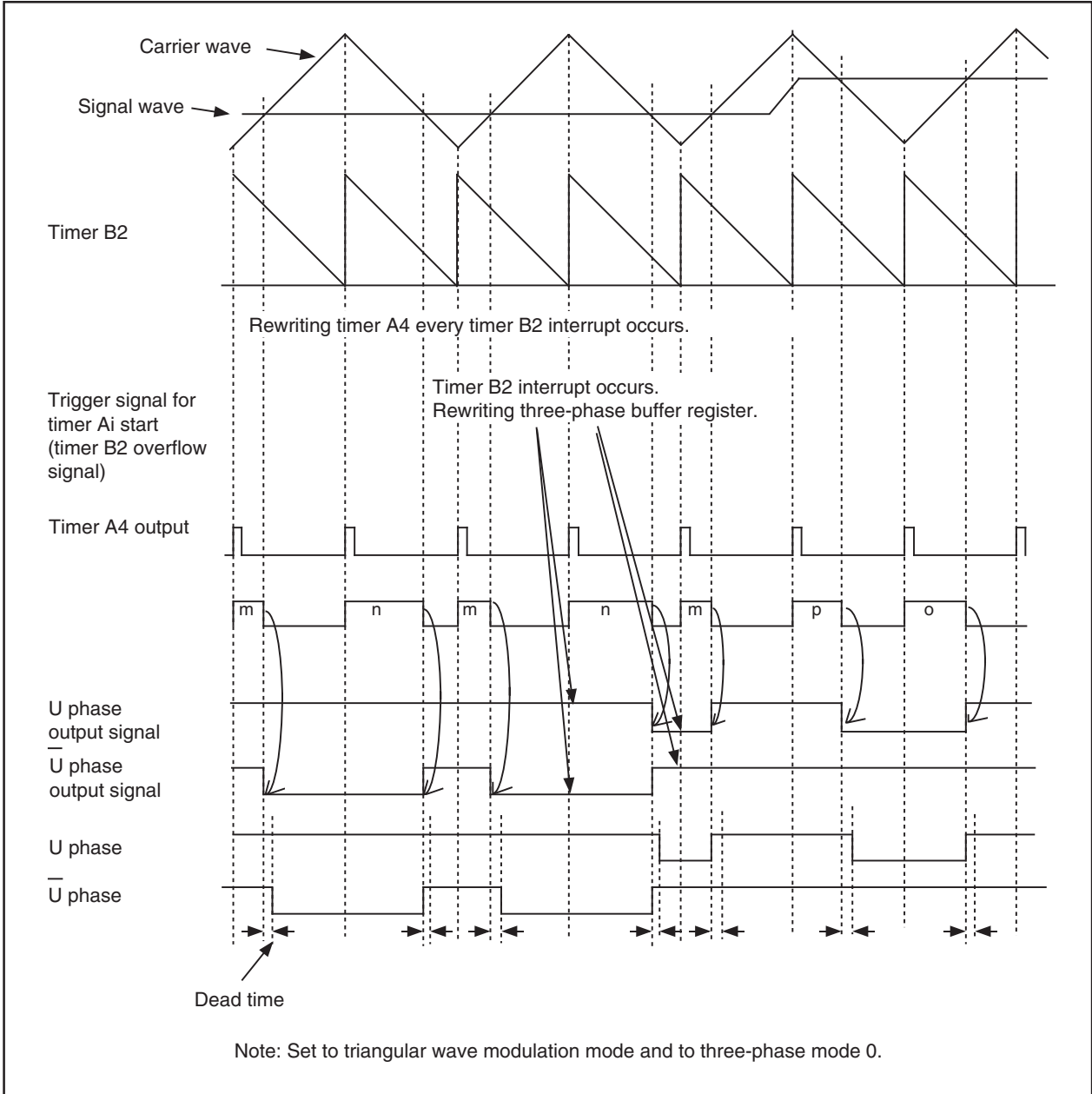

Figure 1.14.9. Timing chart of operation (2)

Figures 1.14.1 to 1.14.5 show registers related to timers for three-phase motor control.

Sawtooth modulation

To generate a PWM waveform of sawtooth wave modulation, set “1” in the modulation mode select bit (bit 6 at 0348₁₆). Also, set “0” in the timers A4-1, A1-1, and A2-1 control bit (bit 1 at 0349₁₆). In this mode, the timer registers of timers A4, A1, and A2 comprise conventional timers A4, A1, and A2 alone, and reload the corresponding timer register’s content to the counter every time the timer B2 counter’s content becomes 0000₁₆. The effective interrupt output specification bit (bit 1 at 0348₁₆) and the effective interrupt output polarity select bit (bit 0 at 0348₁₆) go nullified.

An example of U phase waveform is shown in Figure 1.14.10, and the description of waveform output workings is given below. Set “1” in DU0 (bit 0 at 034A₁₆), and set “0” in DUB0 (bit 1 at 034A₁₆). In addition, set “0” in DU1 (bit 0 at 034A₁₆) and set “1” in DUB1 (bit 1 at 034A₁₆).

When the timer B2 counter’s content becomes 0000₁₆, timer B2 generates an interrupt, and timer A4 starts outputting one-shot pulses at the same time. In this instance, the contents of the three-phase buffer registers DU1 and DU0 are set in the three-phase output shift register (U phase), and the contents of DUB1 and DUB0 are set in the three-phase output shift register (U phase). After this, the three-phase buffer register’s content is set in the three-phase shift register every time the timer B2 counter’s content becomes 0000₁₆.

The value of DU0 and that of DUB0 are output to the U terminal (P80) and to the U terminal (P81) respectively. When the timer A4 counter counts the value written to timer A4 (038F₁₆, 038E₁₆) and when timer A4 finishes outputting one-shot pulses, the three-phase output shift register’s content is shifted one position, and the value of DU1 and that of DUB1 are output to the U phase output signal and to the U output signal respectively. At this time, one-shot pulses are output from the timer for setting dead time used for setting the time over which the “L” level of the U phase waveform doesn’t lap over the “L” level of the U phase waveform, which has the opposite phase of the former. The U phase waveform output that started from the “H” level keeps its level until the timer for setting dead time finishes outputting one-shot pulses even though the three-phase output shift register’s content changes from “1” to “0” by the effect of the one-shot pulses. When the timer for setting dead time finishes outputting one-shot pulses, 0 already shifted in the three-phase shift register goes effective, and the U phase waveform changes to the “L” level. When the timer B2 counter’s content becomes 0000₁₆, the contents of the three-phase buffer registers DU1 and DU0 are set in the three-phase output shift register (U phase), and the contents of DUB1 and DUB0 are set in the three-phase output shift register (U phase) again.

A U phase waveform is generated by these workings repeatedly. With the exception that the three-phase output shift register on the U phase side is used, the workings in generating a U phase waveform, which has the opposite phase of the U phase waveform, are the same as in generating a U phase waveform. In this way, a waveform can be picked up from the applicable terminal in a manner in which the “L” level of the U phase waveform doesn’t lap over that of the U phase waveform, which has the opposite phase of the U phase waveform. The width of the “L” level too can be adjusted by varying the values of timer B2 and timer A4. In dealing with the V and W phases, and V and W phases, the latter are of opposite phase of the former, have the corresponding timers work similarly to dealing with the U and U phases to generate an intended waveform.

Setting “1” both in DUB0 and in DUB1 provides a means to output the U phase alone and to fix the U phase output to “H” as shown in Figure 1.14.11.

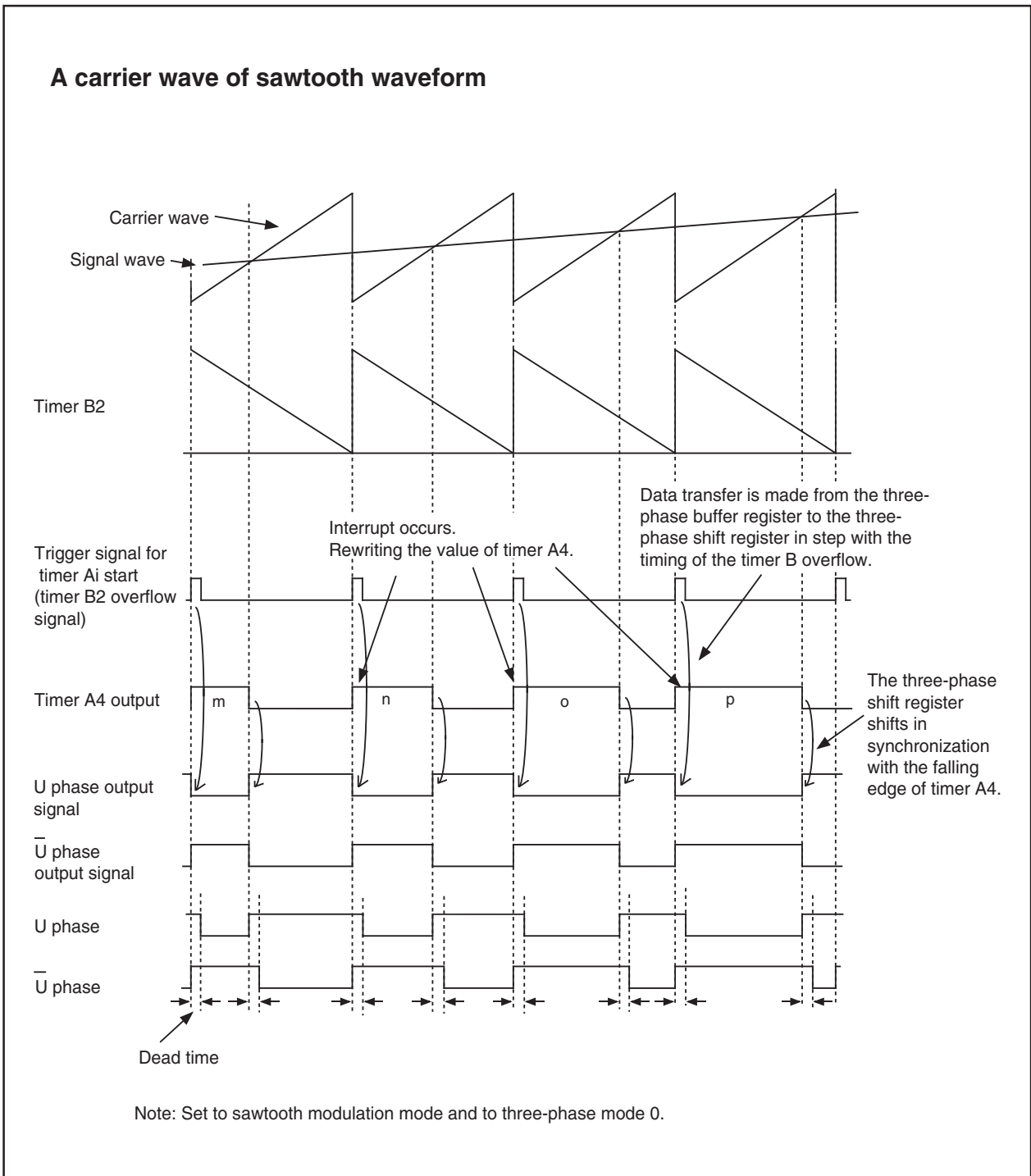

Figure 1.14.10. Timing chart of operation (3)

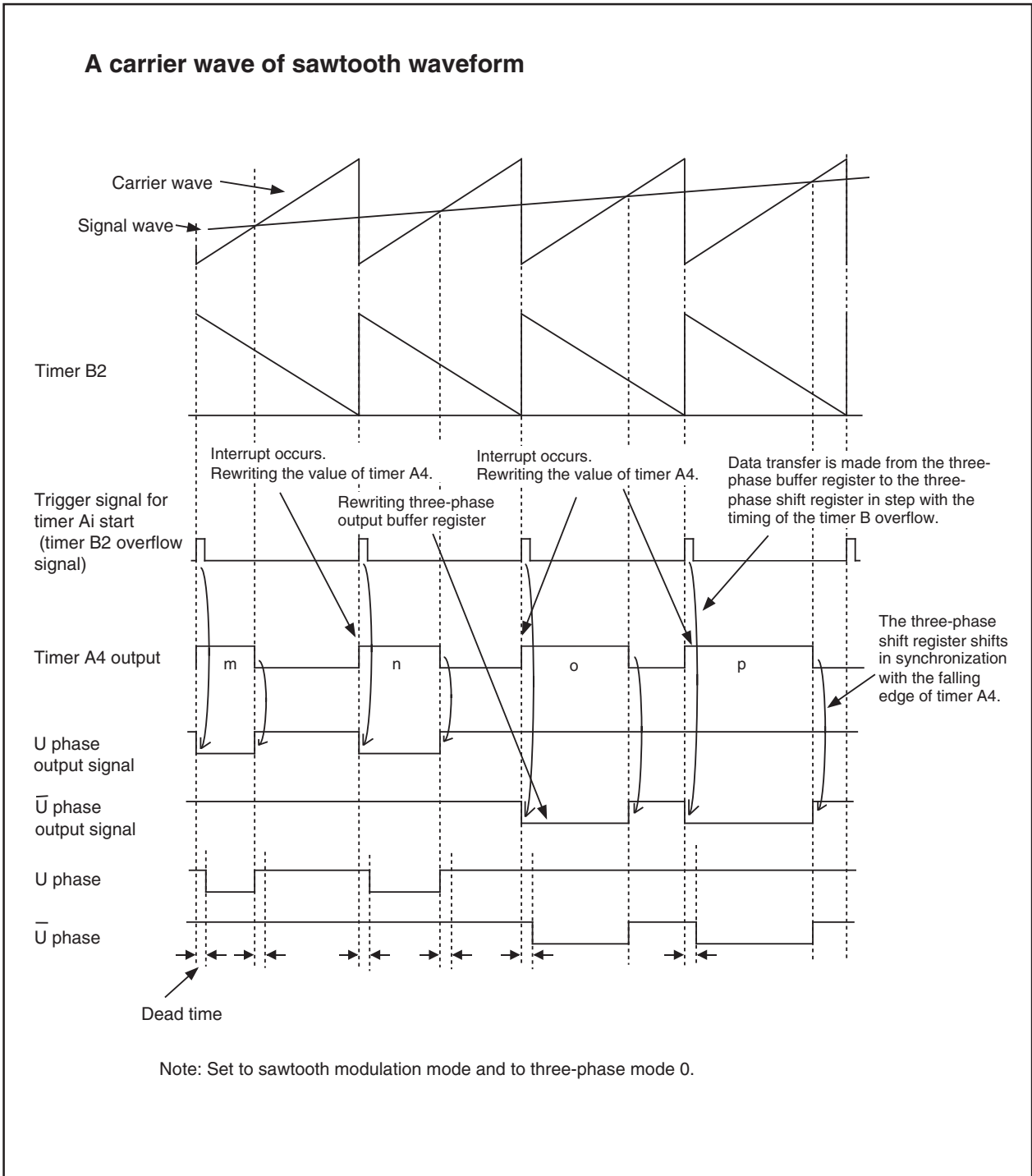

Figure 1.14.11. Timing chart of operation (4)

Serial I/O

Serial I/O is configured as three channels: UART0, UART1, and UART2.

UARTi (i = 0 to 2)

UART0, UART1 and UART2 each have an exclusive timer to generate a transfer clock, so they operate independently of each other.

Figure 1.15.1 shows the block diagram of UART0, UART1 and UART2. Figures 1.15.2 and 1.15.3 show the block diagram of the transmit/receive unit.

UARTi (i = 0 to 2) has two operation modes: a clock synchronous serial I/O mode and a clock asynchronous serial I/O mode (UART mode). The contents of the serial I/O mode select bits (bits 0 to 2 at addresses 03A0₁₆, 03A8₁₆ and 0378₁₆) determine whether UARTi is used as a clock synchronous serial I/O or as a UART. Although a few functions are different, UART0, UART1 and UART2 have almost the same functions. UART2, in particular, is used for the SIM (Subscriber Identity Module) interface with some extra settings added in clock-asynchronous serial I/O mode.

Table 1.15.1 shows the comparison of functions of UART0 through UART2, and Figures 1.15.4 to 1.15.10 show the registers related to UARTi.

Table 1.15.1. Comparison of functions of UART0 through UART2

Function	UART0	UART1	UART2
CLK polarity selection	Supported (Note 1)	Supported (Note 1)	Supported (Note 1)
LSB first / MSB first selection	Supported (Note 1)	Supported (Note 1)	Supported (Note 2)
Continuous receive mode selection	Supported (Note 1)	Supported (Note 1)	Supported (Note 1)
Transfer clock output from multiple pins selection	Not Supported	Supported (Note 1)	Not Supported
Serial data logic switch	Not Supported	Not Supported	Supported (Note 3)
TxD, RxD I/O polarity switch	Not Supported	Not Supported	Supported
TxD, RxD port output format	CMOS output/Nch OD	CMOS output/Nch OD	N-channel open-drain output
Parity error signal output	Not Supported	Not Supported	Supported (Note 3)
Bus collision detection	Not Supported	Not Supported	Supported

Note 1: Only when in clock synchronous serial I/O mode.

Note 2: Only when in clock synchronous serial I/O mode and 8-bit UART mode.

Note 3: Used for SIM interface.

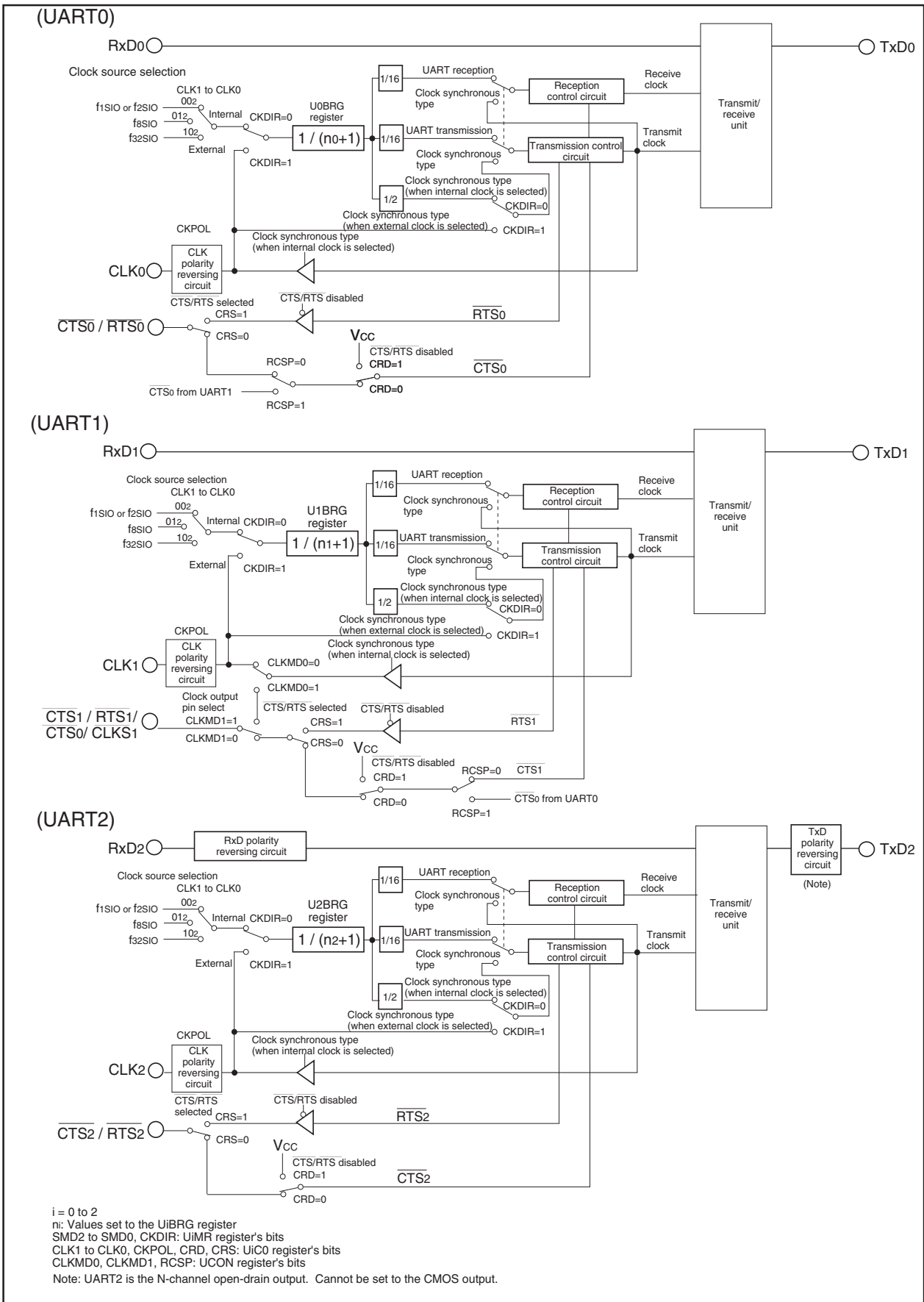

Figure 1.15.1. Block diagram of UARTi (i = 0 to 2)

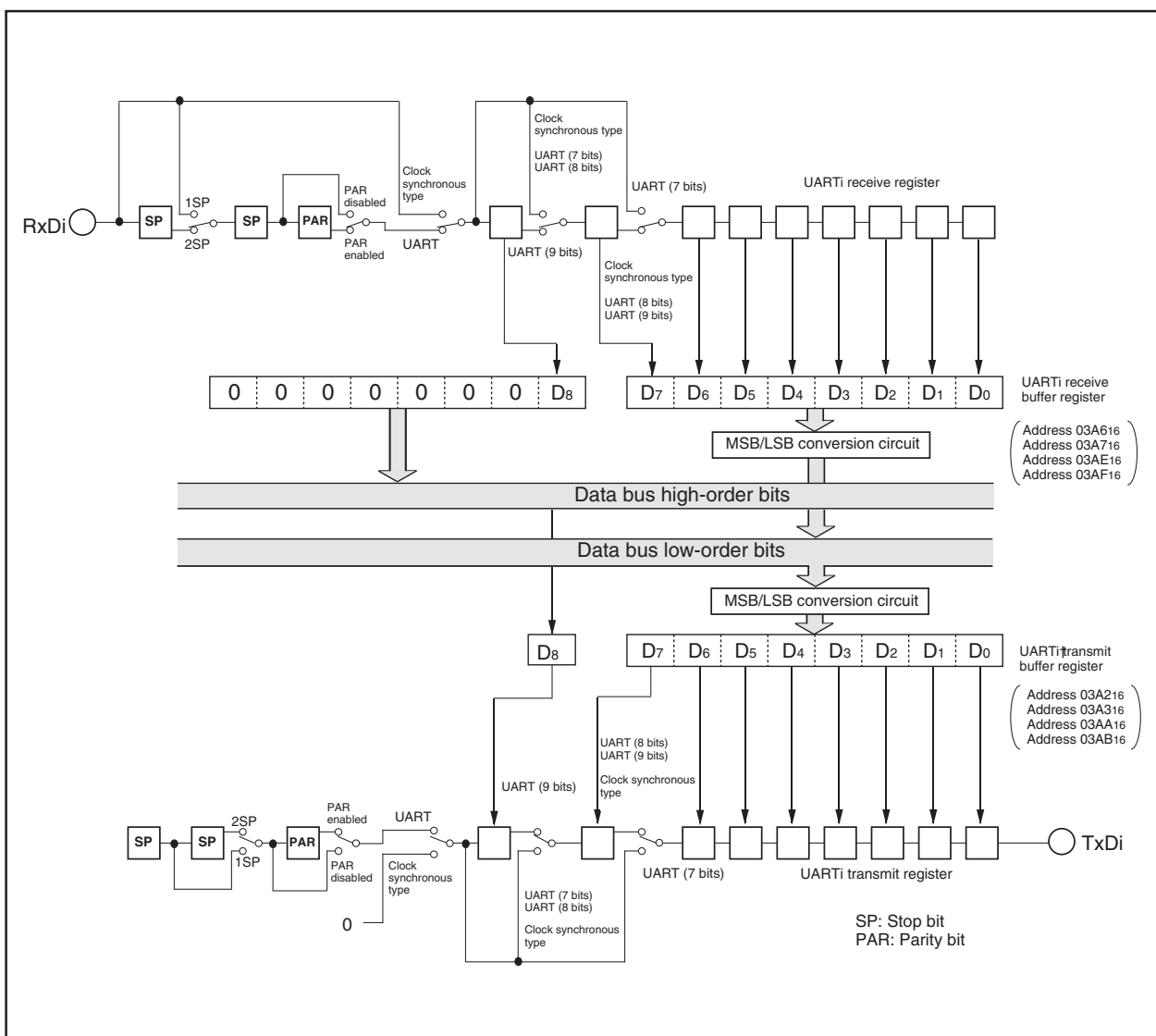

Figure 1.15.2. Block diagram of UARTi (i = 0, 1) transmit/receive unit

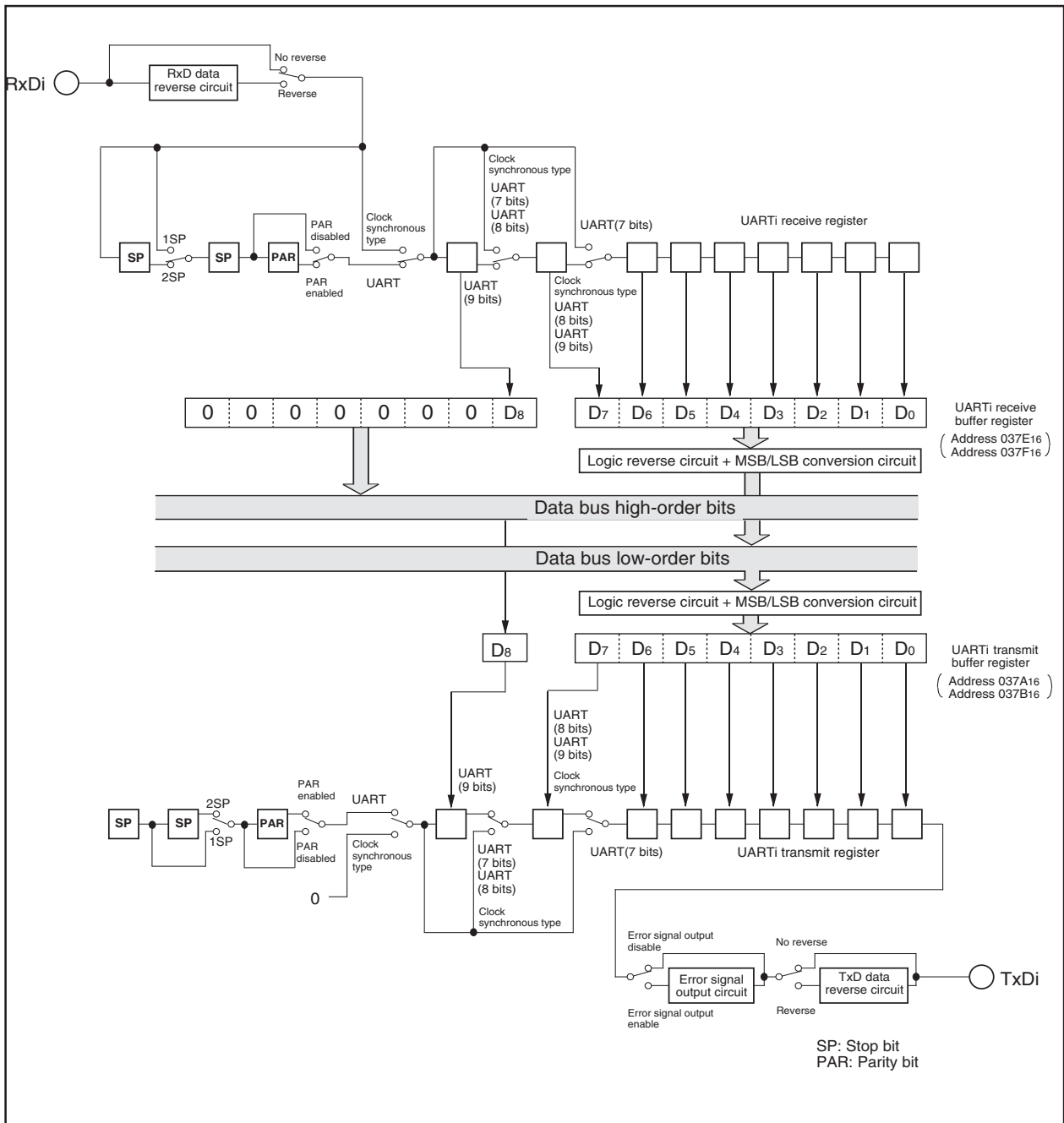

Figure 1.15.3. Block diagram of UART2 transmit/receive unit

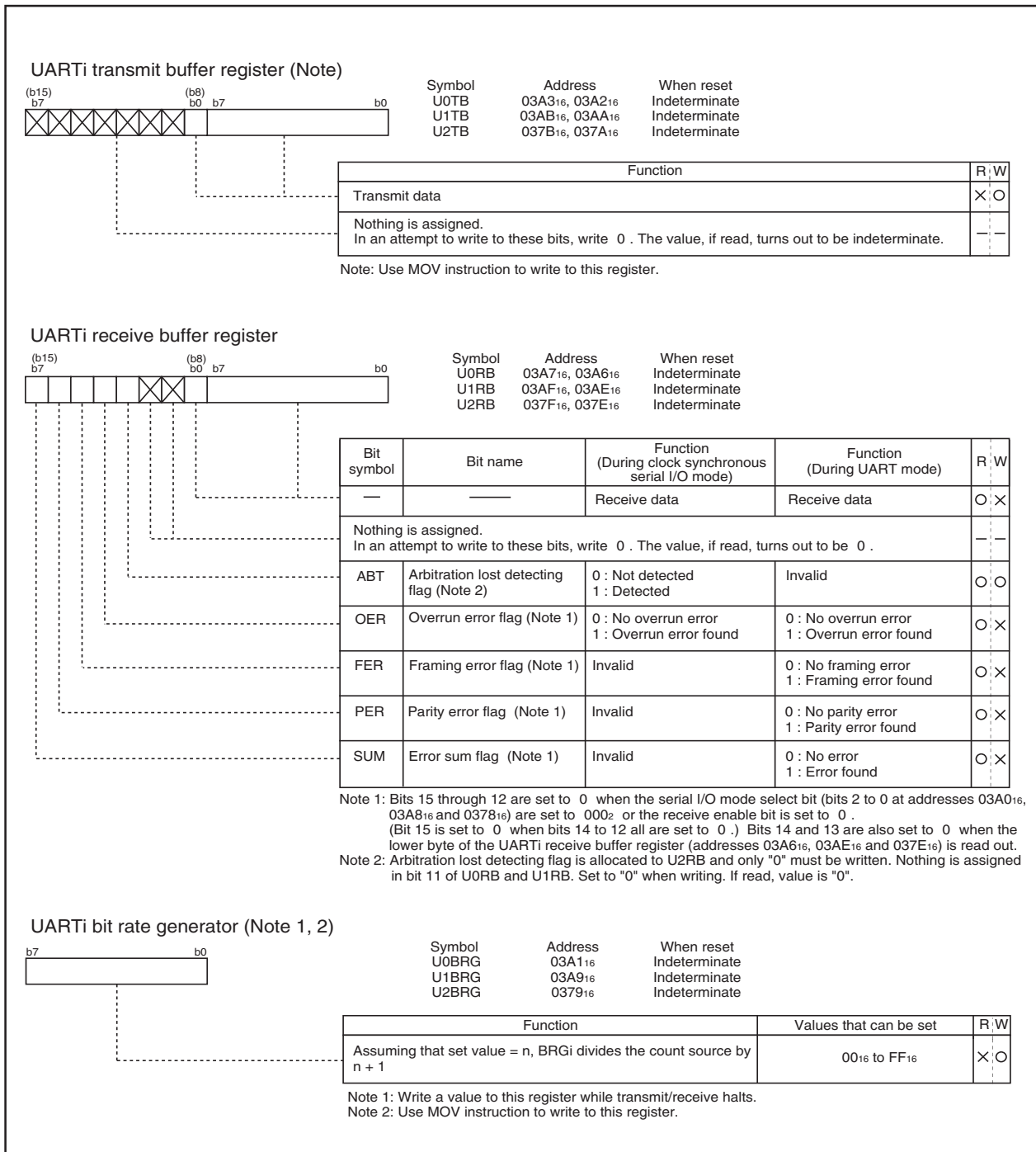

Figure 1.15.4. Serial I/O-related registers (1)

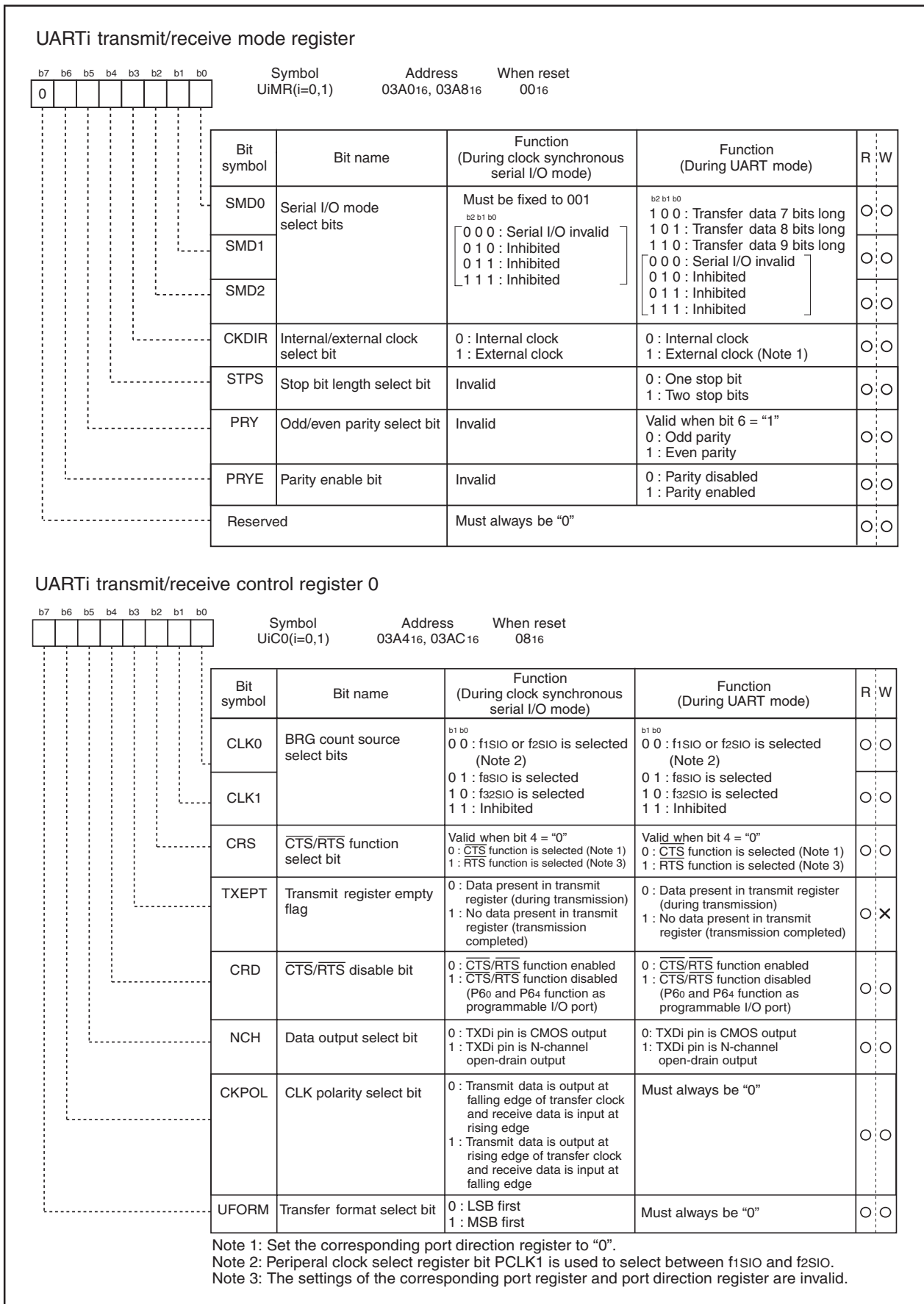

Figure 1.15.5. Serial I/O-related registers (2)

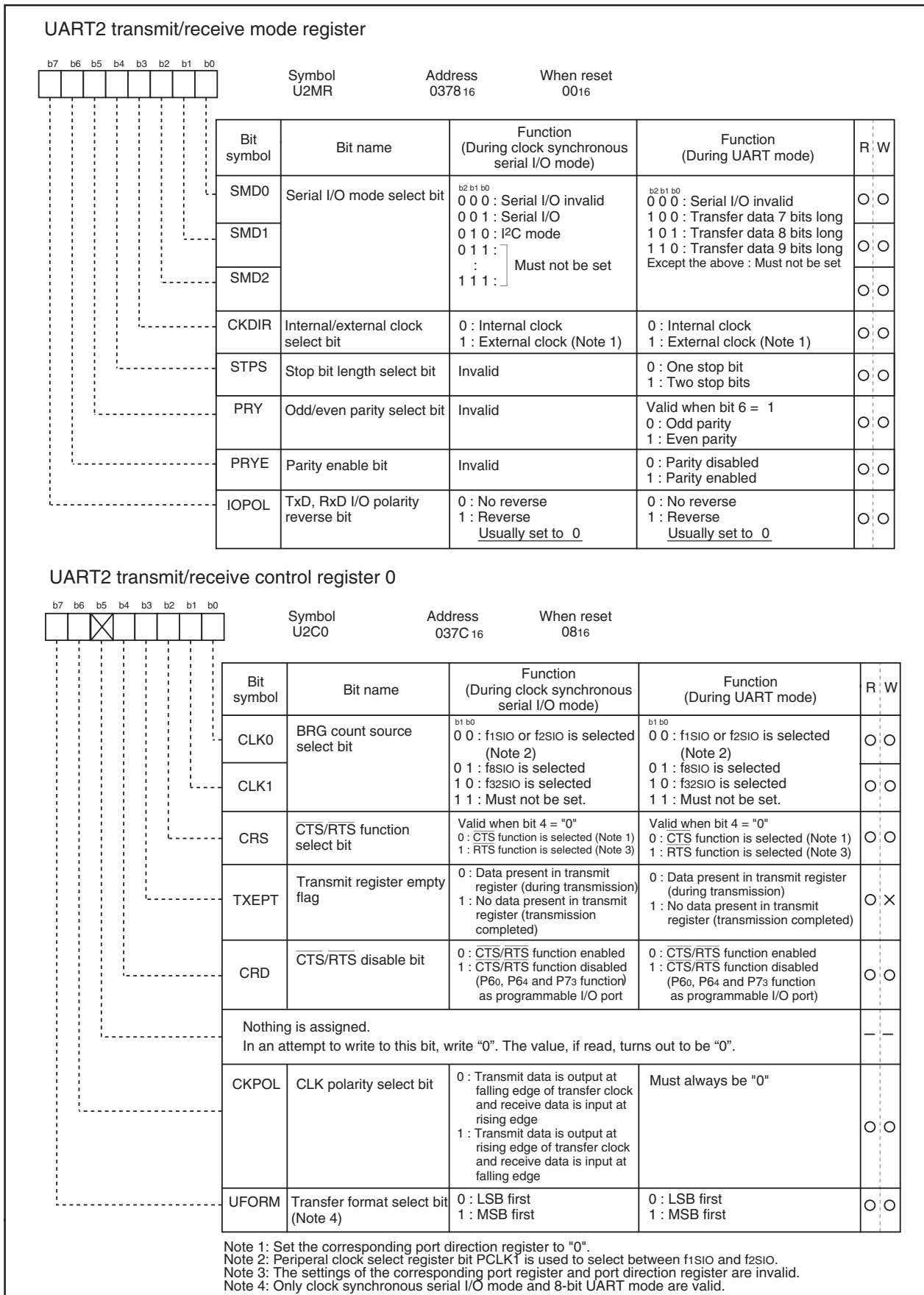

Figure 1.15.6. Serial I/O-related registers (3)

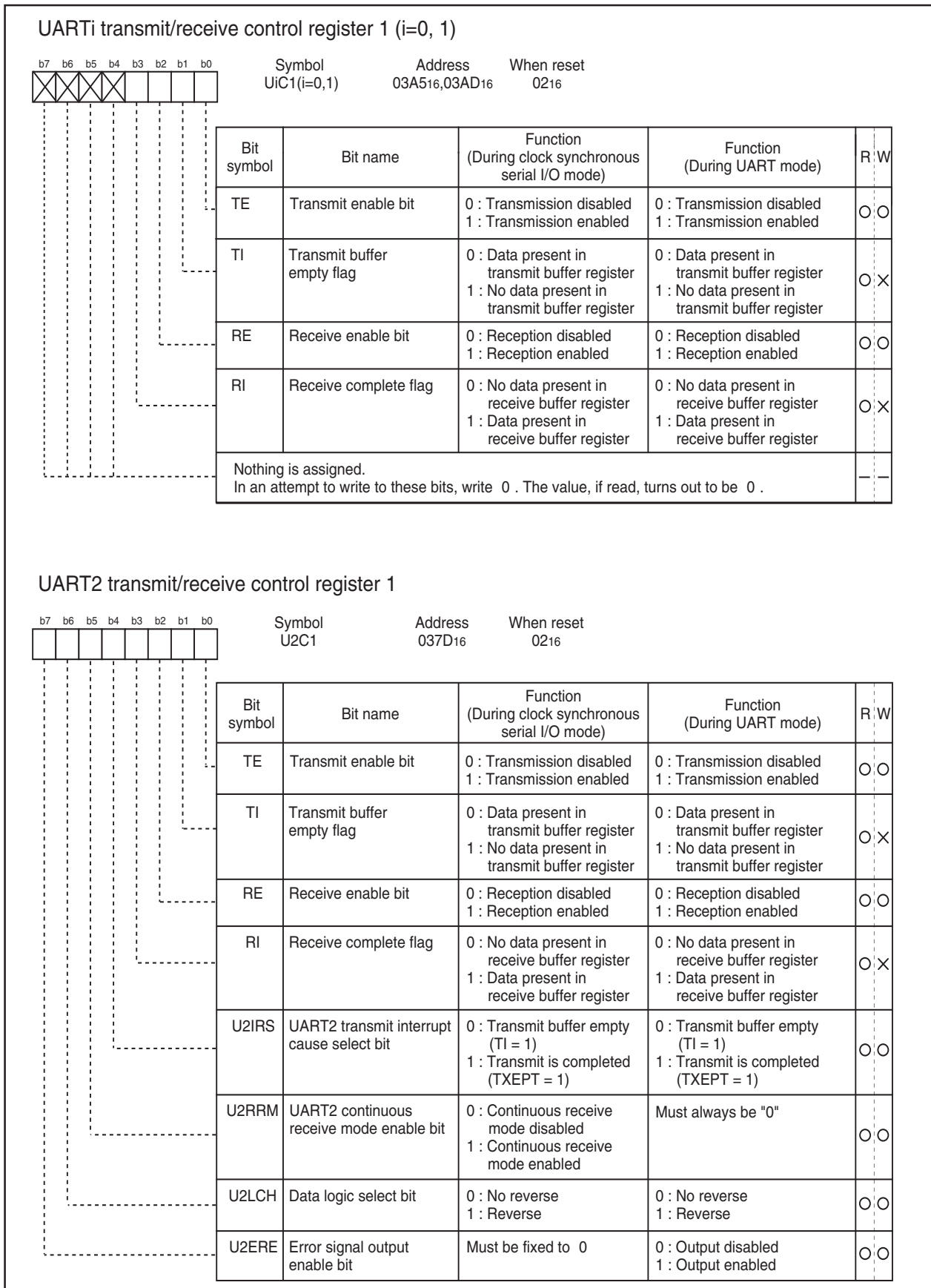

Figure 1.15.7. Serial I/O-related registers (4)

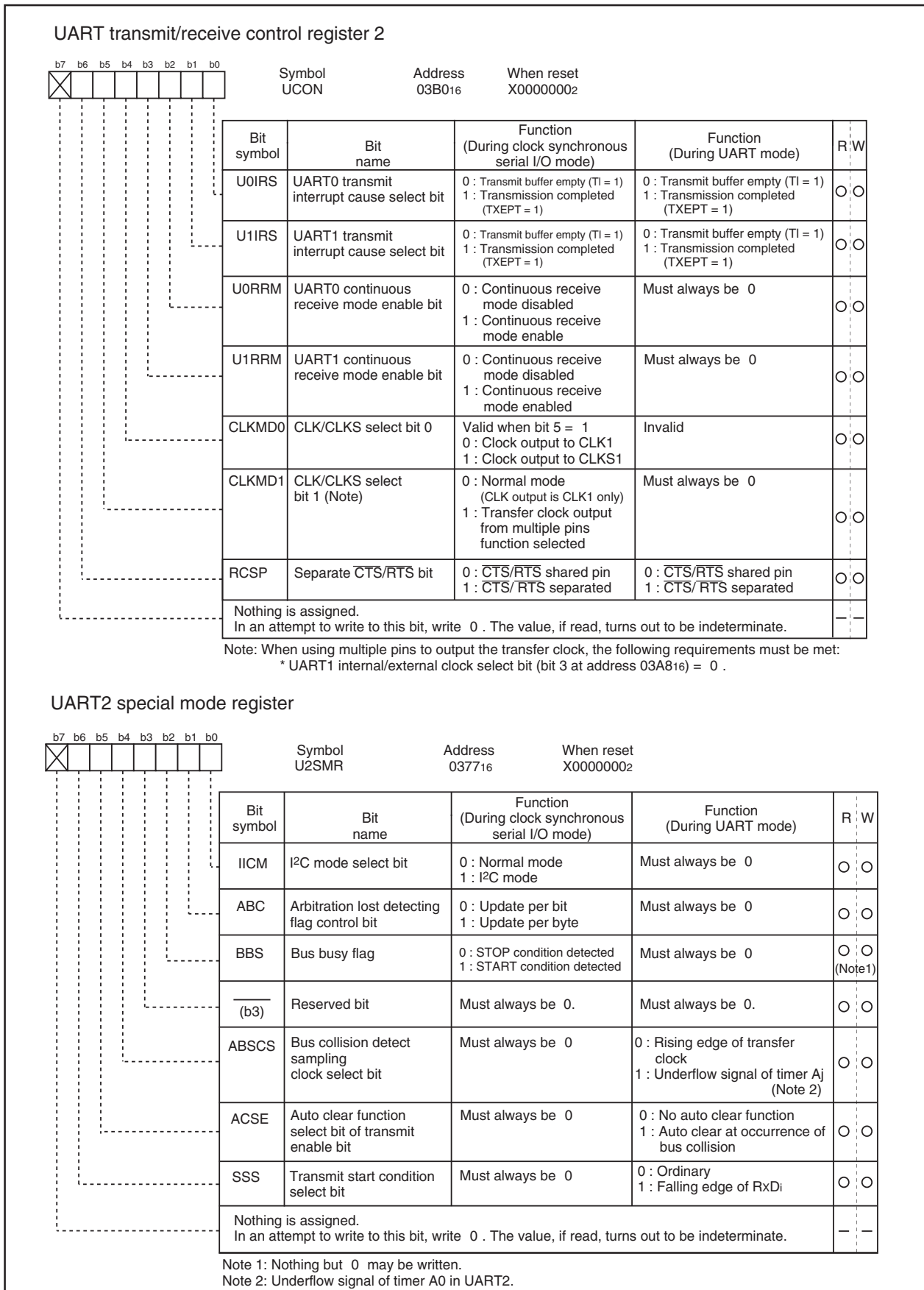

Figure 1.15.8. Serial I/O-related registers (5)

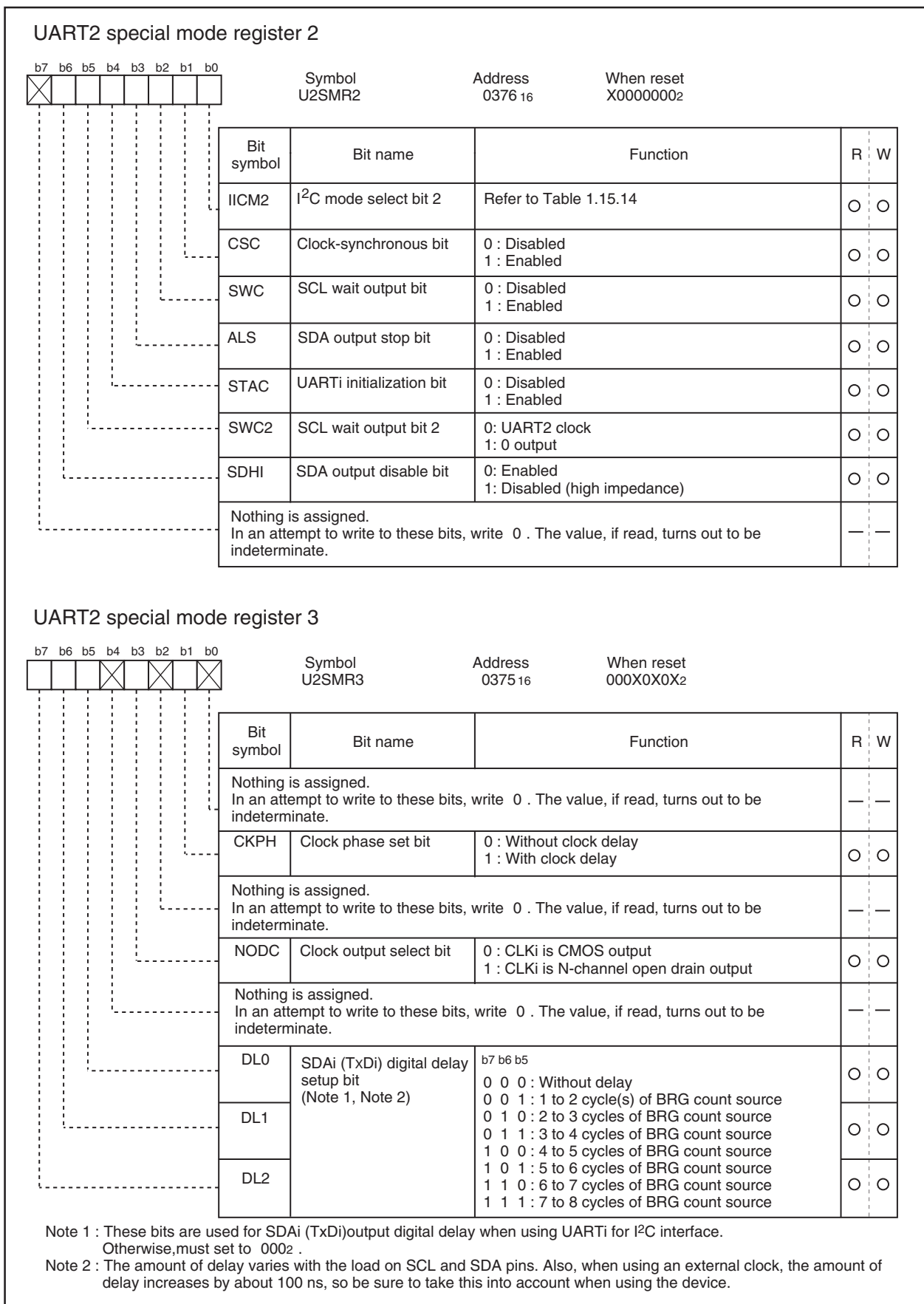

Figure 1.15.9. Serial I/O-related registers (6)

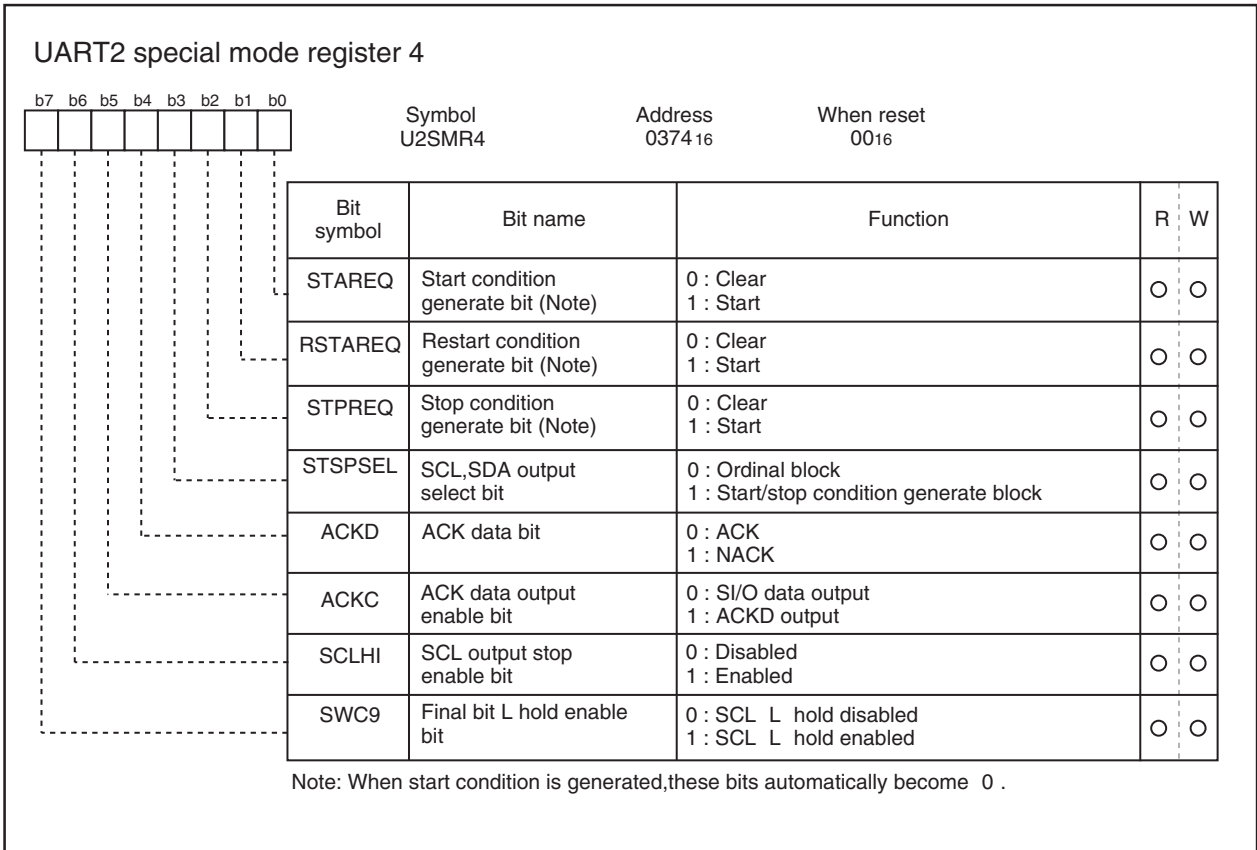

Figure 1.15.10. Serial I/O-related registers (7)

Clock Synchronous Serial I/O Mode

The clock synchronous serial I/O mode uses a transfer clock to transmit and receive data. Tables 1.15.2 and 1.15.3 list the specifications of the clock synchronous serial I/O mode. Figure 1.15.11 shows the UART_i transmit/receive mode register.

Table 1.15.2. Specifications of clock synchronous serial I/O mode (1)

Item	Specification
Transfer data format	<ul style="list-style-type: none"> Transfer data length: 8 bits
Transfer clock 0378 ₁₆	<ul style="list-style-type: none"> When internal clock is selected (bit 3 at addresses 03A0₁₆, 03A8₁₆, 0378₁₆ = "0") : $f_i / 2(n+1)$ (Note 1) $f_i = f_{1SIO}, f_{2SIO}, f_{8SIO}, f_{32SIO}$ <ul style="list-style-type: none"> When external clock is selected (bit 3 at addresses 03A0₁₆, 03A8₁₆, = "1") : Input from CLK_i pin
Transmission/reception control	<ul style="list-style-type: none"> CTS function, RTS function, CTS and RTS function disabled: selectable
Transmission start condition	<ul style="list-style-type: none"> To start transmission, the following requirements must be met: <ul style="list-style-type: none"> Transmit enable bit (bit 0 at addresses 03A5₁₆, 03AD₁₆, 037D₁₆) = "1" Transmit buffer empty flag (bit 1 at addresses 03A5₁₆, 03AD₁₆, 037D₁₆) = "0" When CTS function selected, CTS input level = "L" Furthermore, if external clock is selected, the following requirements must also be met: <ul style="list-style-type: none"> CLK_i polarity select bit (bit 6 at addresses 03A4₁₆, 03AC₁₆, 037C₁₆) = "0": CLK_i input level = "H" CLK_i polarity select bit (bit 6 at addresses 03A4₁₆, 03AC₁₆, 037C₁₆) = "1": CLK_i input level = "L"
Reception start condition	<ul style="list-style-type: none"> To start reception, the following requirements must be met: <ul style="list-style-type: none"> Receive enable bit (bit 2 at addresses 03A5₁₆, 03AD₁₆, 037D₁₆) = "1" Transmit enable bit (bit 0 at addresses 03A5₁₆, 03AD₁₆, 037D₁₆) = "1" Transmit buffer empty flag (bit 1 at addresses 03A5₁₆, 03AD₁₆, 037D₁₆) = "0" Furthermore, if external clock is selected, the following requirements must also be met: <ul style="list-style-type: none"> CLK_i polarity select bit (bit 6 at addresses 03A4₁₆, 03AC₁₆, 037C₁₆) = "0": CLK_i input level = "H" CLK_i polarity select bit (bit 6 at addresses 03A4₁₆, 03AC₁₆, 037C₁₆) = "1": CLK_i input level = "L"
Interrupt request generation timing UART _i	<ul style="list-style-type: none"> When transmitting <ul style="list-style-type: none"> Transmit interrupt cause select bit (bits 0, 1 at address 03B0₁₆, bit 4 at address 037D₁₆) = "0": Interrupts requested when data transfer from transfer buffer register to UART_i transmit register is completed Transmit interrupt cause select bit (bits 0, 1 at address 03B0₁₆, bit 4 at address 037D₁₆) = "1": Interrupts requested when data transmission from UART_i transfer register is completed When receiving <ul style="list-style-type: none"> Interrupts requested when data transfer from UART_i receive register to UART_i receive buffer register is completed
Error detection	<ul style="list-style-type: none"> Overrun error (Note 2) Generated 7 clock periods after the device started receiving the next data before reading out the contents of the UART_i receive buffer register.

Note 1: "n" denotes the value 00₁₆ to FF₁₆ that is set in the UART bit rate generator.

Note 2: If an overrun error occurs, the UART_i receive buffer will have the next data written in. In addition, the UART_i receive interrupt request bit does not change.

Table 1.15.3. Specifications of clock synchronous serial I/O mode (2)

Item	Specification
Select function	<ul style="list-style-type: none"><li data-bbox="496 342 1406 454">• CLK polarity selection Whether transmit data output/input timing is at the rising edge or falling edge of the transfer clock can be selected<li data-bbox="496 461 1406 528">• LSB first/MSB first selection Whether transmission/reception begins with bit 0 or bit 7 can be selected<li data-bbox="496 539 1406 651">• Continuous receive mode selection Reception is enabled automatically after the receive buffer register is read<li data-bbox="496 663 1406 808">• Switching serial data logic (UART2) Whether to invert data (1's complement) when writing to the transmission buffer register or reading the reception buffer register can be selected.<li data-bbox="496 819 1406 931">• TxD, RxD I/O polarity reverse (UART2) This function inverts the TxD port output and RxD port input. All I/O data level is reversed.<li data-bbox="496 943 1406 1043">• Transfer clock output from multiple pins selection (UART1) UART1 transfer clock can be chosen by software to be output from one of the two pins set

Table 1.15.4. Registers used in clock synchronous serial I/O mode and the register values set

Register	Bit	Function
UiTB(Note3)	0 to 7	Set transmission data
UiRB(Note3)	0 to 7	Reception data can be read
	OER	Overflow error flag
UiBRG	0 to 7	Set a transfer rate
UiMR(Note3)	SMD2 to SMD0	Set to "0012"
	CKDIR	Select the internal clock or external clock
	IOPOL	Set to "0"
UiC0	CLK1 to CLK0	Select the count source for the UiBRG register
	CRS	Select CTS or RTS to use
	TXEPT	Transmit register empty flag
	CRD	Enable or disable the CTS or RTS function
	NCH	Select TxDi pin output mode (Note 2)
	CKPOL	Select the transfer clock polarity
	UFORM	Select the LSB first or MSB first
UiC1	TE	Set this bit to "1" to enable transmission/reception
	TI	Transmit buffer empty flag
	RE	Set this bit to "1" to enable reception
	RI	Reception complete flag
	U2IRS (Note 1)	Select the source of UART2 transmit interrupt
	U2RRM (Note 1)	Set this bit to "1" to use continuous receive mode
	UiLCH	Set this bit to "1" to use inverted data logic
	UiERE	Set to "0"
UiSMR	0 to 7	Set to "0"
UiSMR2	0 to 7	Set to "0"
UiSMR3	0 to 2	Set to "0"
	NODC	Select clock output mode
	4 to 7	Set to "0"
UiSMR4	0 to 7	Set to "0"
UCON	U0IRS, U1IRS	Select the source of UART0/UART1 transmit interrupt
	U0RRM, U1RRM	Set this bit to "1" to use continuous receive mode
	CLKMD0	Select the transfer clock output pin when CLKMD1 = 1
	CLKMD1	Set this bit to "1" to output UART1 transfer clock from two pins
	RCSP	Set this bit to "1" to accept as input the UART0 CTS0 signal from the P64 pin
	7	Set to "0"

Note 1: Set the U0C1 and U1C1 register bit 4 and bit 5 to "0". The U0IRS, U1IRS, U0RRM and U1RRM bits are in the UCON register.

Note 2: TxD2 pin is N channel open-drain output. Set the U2C0 register's NCH bit to "0".

Note 3: Not all register bits are described above. Set those bits to "0" when writing to the registers in clock synchronous serial I/O mode.

i=0 to 2

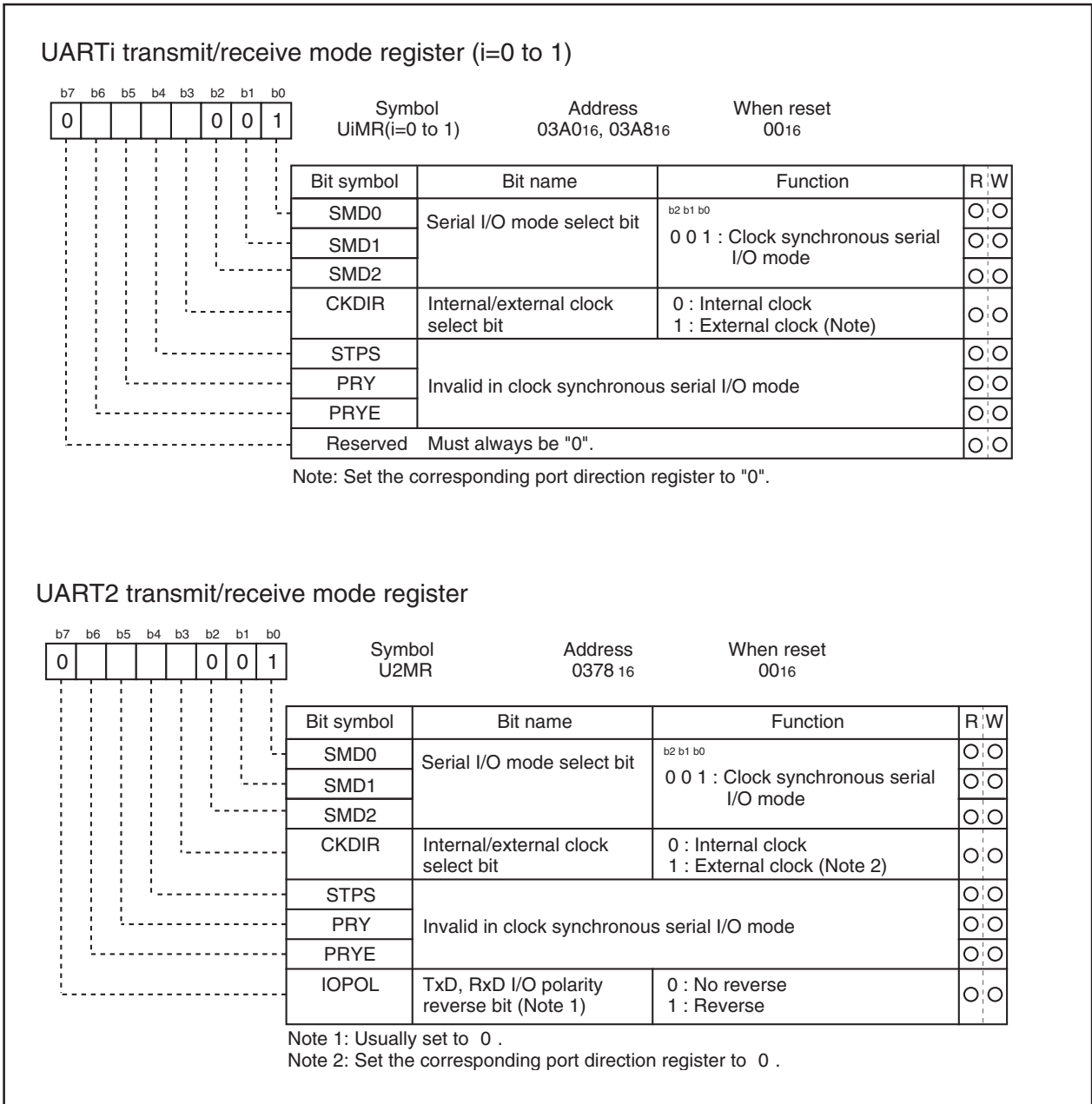

Figure 1.15.11. UART_i transmit/receive mode register in clock synchronous serial I/O mode

Table 1.15.5 lists the functions of the input/output pins during clock synchronous serial I/O mode. This table shows the pin functions when the transfer clock output from multiple pins function is not selected. Note that for a period from when the UARTi operation mode is selected to when transfer starts, the TxDi pin outputs an “H”. (If the N-channel open-drain is selected, this pin is in floating state.)

Table 1.15.5. Input/output pin functions in clock synchronous serial I/O mode
(when transfer clock output from multiple pins is not selected)

Pin name	Function	Method of selection
TxDi (P63, P67, P70)	Serial data output	(Outputs dummy data when performing reception only)
RxDi (P62, P66, P71)	Serial data input	Port P62, P66 and P71 direction register (bits 2 and 6 at address 03EE16, bit 1 at address 03EF16) = 0 (Can be used as an input port when performing transmission only)
CLKi (P61, P65, P72)	Transfer clock output	Internal/external clock select bit (bit 3 at address 03A016, 03A816, 037816) = 0
	Transfer clock input	Internal/external clock select bit (bit 3 at address 03A016, 03A816, 037816) = 1 Port P61, P65 and P72 direction register (bits 1 and 5 at address 03EE16, bit 2 at address 03EF16) = 0
CTS _i /RTS _i (P60, P64, P73)	CTS input	CTS/RTS disable bit (bit 4 at address 03A416, 03AC16, 037C16) = 0 CTS/RTS function select bit (bit 2 at address 03A416, 03AC16, 037C16) = 0 Port P60, P64 and P73 direction register (bits 0 and 4 at address 03EE16, bit 3 at address 03EF16) = 0
	RTS output	CTS/RTS disable bit (bit 4 at address 03A416, 03AC16, 037C16) = 0 CTS/RTS function select bit (bit 2 at address 03A416, 03AC16, 037C16) = 1
	Programmable I/O port	CTS/RTS disable bit (bit 4 at address 03A416, 03AC16, 037C16) = 1

Table 1.15.6. P64 pin function in clock synchronous serial I/O mode

Pin function	Bit set value					
	U1C0 register		UCON register			PD6 register
	CRD	CRS	RCSP	CLKMD1	CLKMD0	PD6_4
P64	1	—	0	0	—	Input: 0, Output: 1
CTS ₁	0	0	0	0	—	0
RTS ₁	0	1	0	0	—	—
CTS ₀ (Note1)	0	0	1	0	0	—
CLKS ₁	—	—	—	1(Note 2)	1	—

Note 1: In addition to this, set the U0C0 register's CRD bit to “0” (CTS₀/RTS₀ enabled) and the U0C0 register's CRS bit to “1” (RTS₀ selected).

Note 2: When the CLKMD1 bit = 1 and the CLKMD0 bit = 0, the following logic levels are output:

- High if the U1C0 register's CLKPOL bit = 0
- Low if the U1C0 register's CLKPOL bit = 1

• Example of transmit timing (when internal clock is selected)

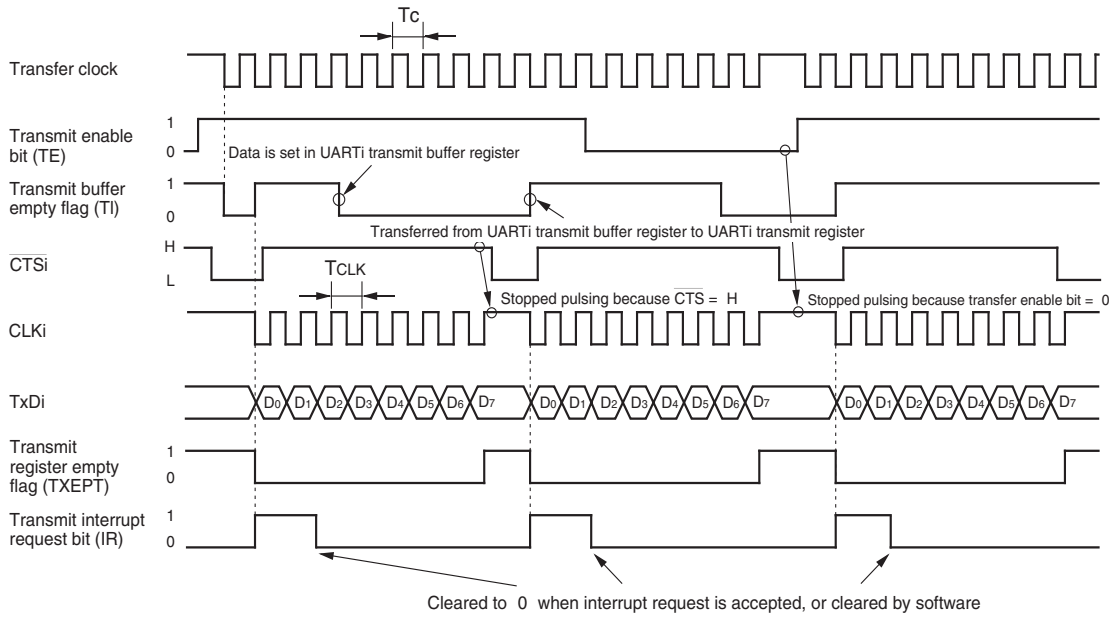

Shown in () are bit symbols.

The above timing applies to the following settings:

- * Internal clock is selected.
- * CTS function is selected
- * CLK polarity select bit = 0 .
- * Transmit interrupt cause select bit = 0 .

$$T_c = T_{CLK} = 2(n + 1) / f_i$$

f_i : frequency of BRGi count source (f_1, f_8, f_{32})
 n : value set to BRGi

• Example of receive timing (when external clock is selected)

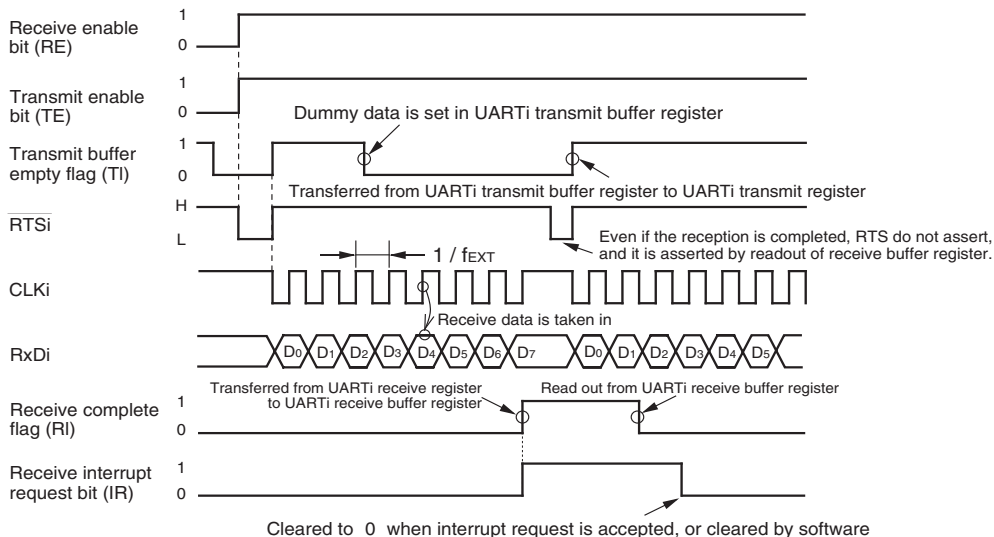

Shown in () are bit symbols.

The above timing applies to the following settings:

- * External clock is selected
- * RTS function is selected
- * CLK polarity select bit = 0 .

f_{EXT} : frequency of external clock

Meet the following conditions are met when the CLK

- input before data reception = H
- * Transmit enable bit → 1
- * Receive enable bit → 1
- * Dummy data write to UARTi transmit buffer register

Figure 1.15.12. Typical transmit/receive timings in clock synchronous serial I/O mode

(a) Polarity select function

As shown in Figure 1.15.13, the CLK polarity select bit (bit 6 at addresses 03A4₁₆, 03AC₁₆, 037C₁₆) allows selection of the polarity of the transfer clock.

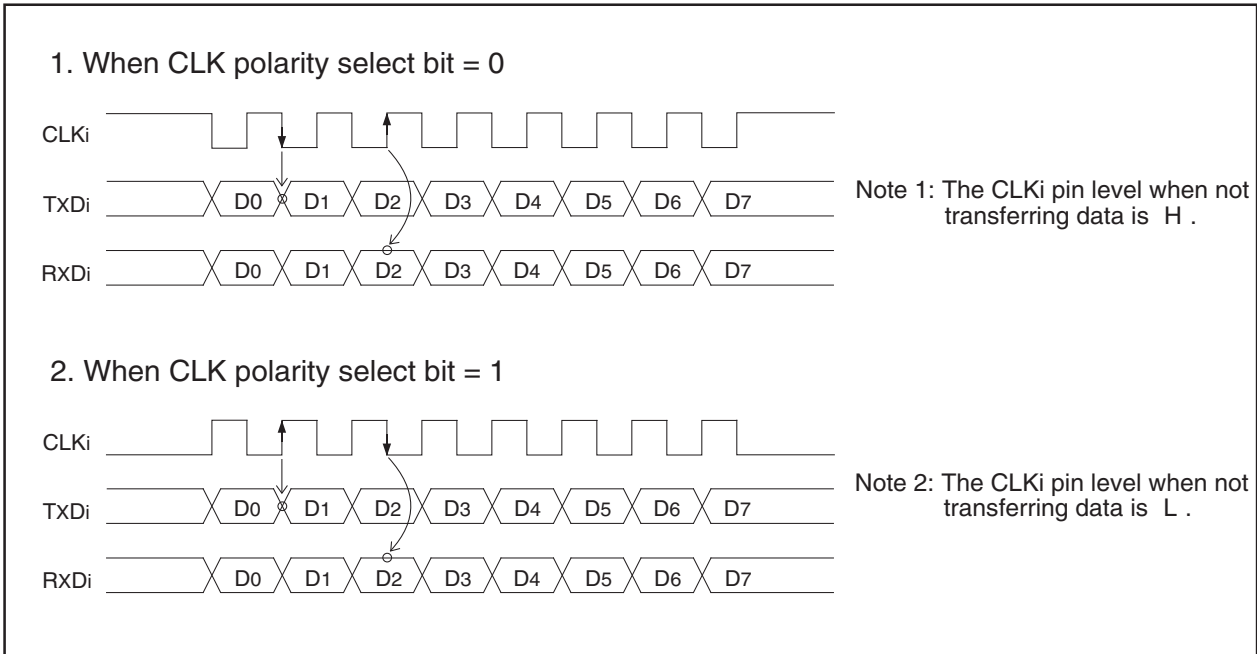

Figure 1.15.13. Polarity of transfer clock

(b) LSB first/MSB first select function

As shown in Figure 1.15.14, when the transfer format select bit (bit 7 at addresses 03A4₁₆, 03AC₁₆, 037C₁₆) = "0", the transfer format is "LSB first"; when the bit = "1", the transfer format is "MSB first".

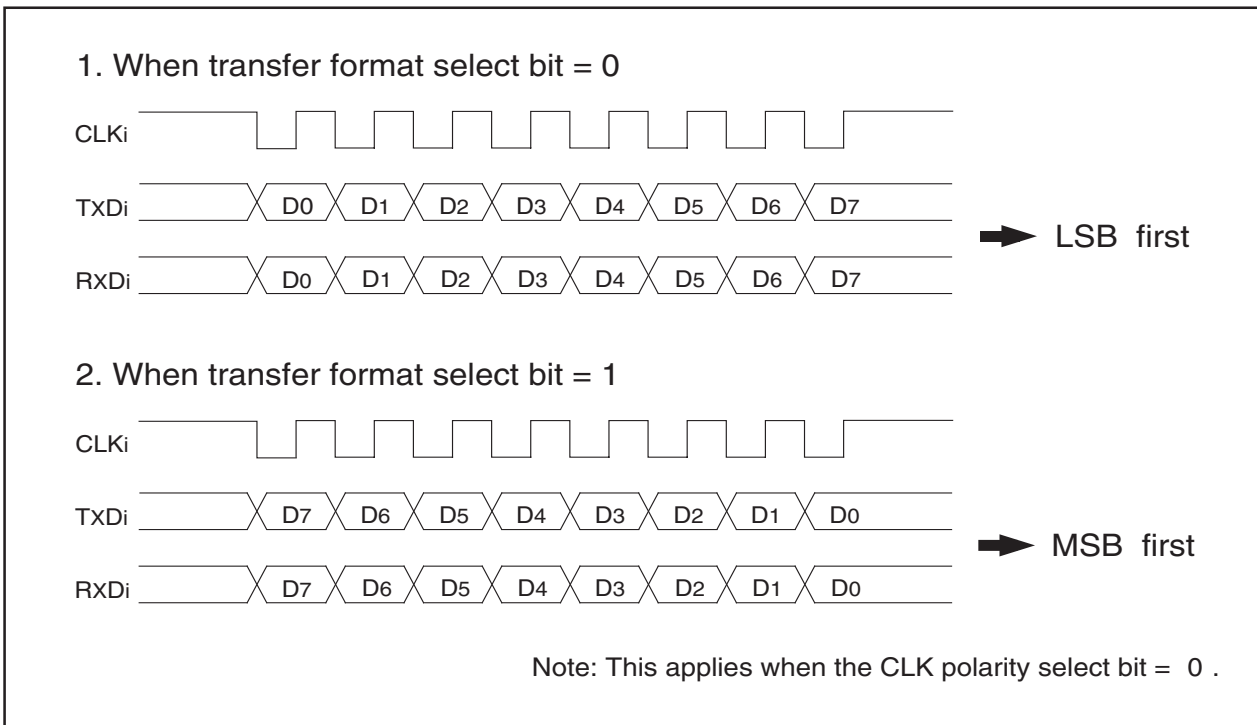

Figure 1.15.14. Transfer format

(c) Transfer clock output from multiple pins function (UART1)

This function allows the setting two transfer clock output pins and choosing one of the two to output a clock by using the CLK and CLKS select bit (bits 4 and 5 at address 03B016). (See Figure 1.15.15.) The multiple pins function is valid only when the internal clock is selected for UART1.

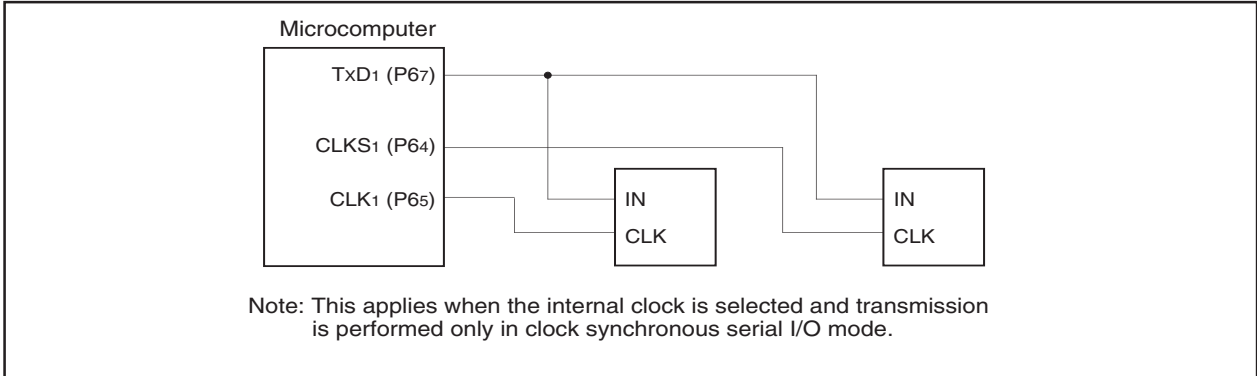

Figure 1.15.15. The transfer clock output from the multiple pins function usage

(d) Continuous receive mode

If the continuous receive mode enable bit (bits 2 and 3 at address 03B016, bit 5 at address 037D16) is set to “1”, the unit is placed in continuous receive mode. In this mode, when the receive buffer register is read out, the SIO simultaneously goes to a receive enable state without having to write dummy data to the transmit buffer register back again.

(e) Serial data logic switch function (UART2)

When the data logic select bit (bit6 at address 037D16) = “1”, and writing to transmit buffer register or reading from receive buffer register, data is reversed. Figure 1.15.16 shows the example of serial data logic switch timing.

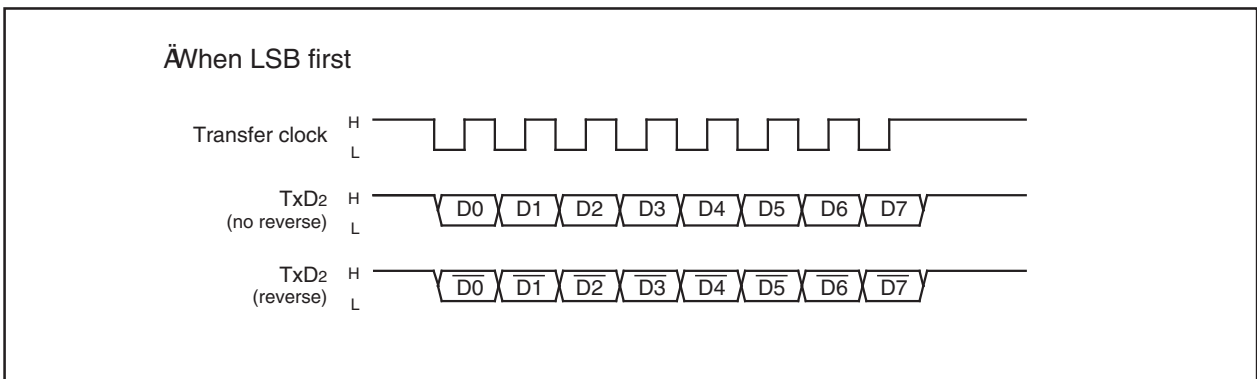

Figure 1.15.16. Serial data logic switch timing

(f) $\overline{\text{CTS}}/\overline{\text{RTS}}$ separate function (UART0)

This function separates $\overline{\text{CTS}}_0/\overline{\text{RTS}}_0$, outputs $\overline{\text{RTS}}_0$ from the P60 pin, and accepts as input the $\overline{\text{CTS}}_0$ from the P64 pin. To use this function, set the register bits as shown below.

- U0C0 register's CRD bit = 0 (enables UART0 $\overline{\text{CTS}}/\overline{\text{RTS}}$)
- U0C0 register's CRS bit = 1 (outputs UART0 $\overline{\text{RTS}}$)
- U1C0 register's CRD bit = 0 (enables UART1 $\overline{\text{CTS}}/\overline{\text{RTS}}$)
- U1C0 register's CRS bit = 0 (inputs UART1 $\overline{\text{CTS}}$)
- UCON register's RCSP bit = 1 (inputs $\overline{\text{CTS}}_0$ from the P64 pin)
- UCON register's CLKMD1 bit = 0 (CLKS1 not used)

Note that when using the $\overline{\text{CTS}}/\overline{\text{RTS}}$ separate function, UART1 $\overline{\text{CTS}}/\overline{\text{RTS}}$ separate function cannot be used.

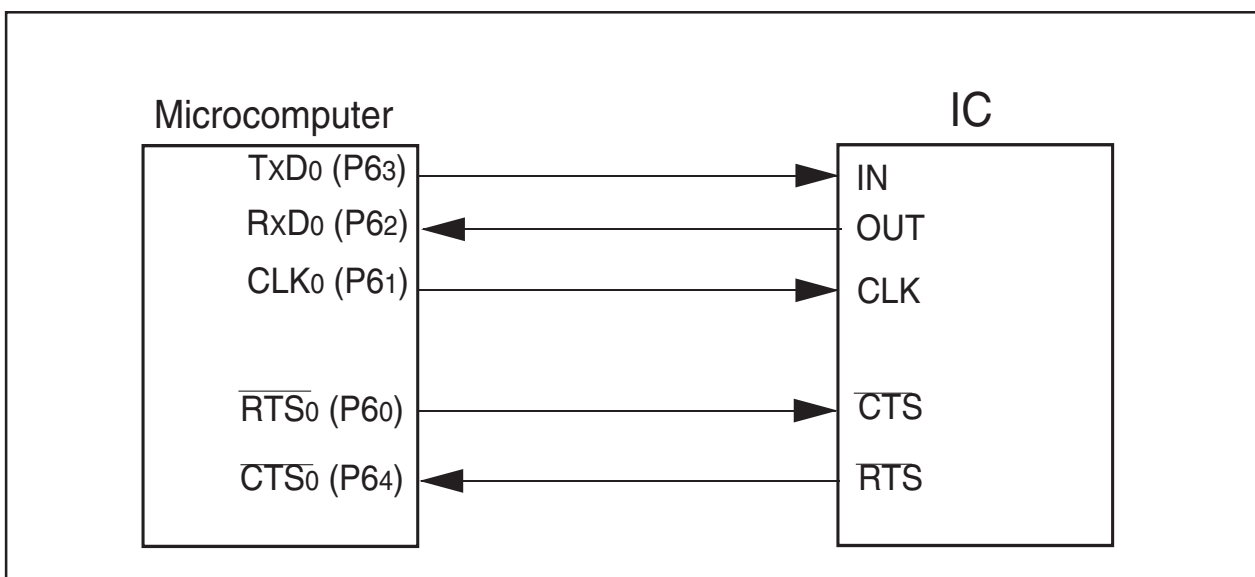

Figure 1.15.17. $\overline{\text{CTS}}/\overline{\text{RTS}}$ separate function usage

Clock Asynchronous Serial I/O (UART) Mode

The UART mode allows transmitting and receiving data after setting the desired transfer rate and transfer data format. Tables 1.15.7 and 1.15.8 list the specifications of the UART mode. Figure 1.15.18 shows the UART_i transmit/receive mode register.

Table 1.15.7. Specifications of UART Mode (1)

Item	Specification
Transfer data format	<ul style="list-style-type: none"> • Character bit (transfer data): 7 bits, 8 bits, or 9 bits as selected • Start bit: 1 bit • Parity bit: Odd, even, or nothing as selected • Stop bit: 1 bit or 2 bits as selected
Transfer clock	<ul style="list-style-type: none"> • When internal clock is selected (bit 3 at addresses 03A0₁₆, 03A8₁₆, 0378₁₆ = "0") : $f_i/16(n+1)$ (Note 1) $f_i = f_{1SIO}, f_{2SIO}, f_{8SIO}, f_{32SIO}$ • When external clock is selected (bit 3 at addresses 03A0₁₆, 03A8₁₆, 0378₁₆ = "1") : $f_{EXT}/16(n+1)$ (Note 1) (Note 2)
Transmission/reception control	<ul style="list-style-type: none"> • CTS function, RTS function, CTS and RTS function disabled: selectable
Transmission start condition	<ul style="list-style-type: none"> • To start transmission, the following requirements must be met: <ul style="list-style-type: none"> - Transmit enable bit (bit 0 at addresses 03A5₁₆, 03AD₁₆, 037D₁₆) = "1" - Transmit buffer empty flag (bit 1 at addresses 03A5₁₆, 03AD₁₆, 037D₁₆) = "0" - When CTS function selected, CTS input level = "L"
Reception start condition	<ul style="list-style-type: none"> • To start reception, the following requirements must be met: <ul style="list-style-type: none"> - Receive enable bit (bit 2 at addresses 03A5₁₆, 03AD₁₆, 037D₁₆) = "1" - Start bit detection
Interrupt request generation timing	<ul style="list-style-type: none"> • When transmitting <ul style="list-style-type: none"> - Transmit interrupt cause select bits (bits 0,1 at address 03B0₁₆, bit4 at address 037D₁₆) = "0": Interrupts requested when data transfer from UART_i transfer buffer register to UART_i transmit register is completed - Transmit interrupt cause select bits (bits 0, 1 at address 03B0₁₆, bit4 at address 037D₁₆) = "1": Interrupts requested when data transmission from UART_i transfer register is completed • When receiving <ul style="list-style-type: none"> - Interrupts requested when data transfer from UART_i receive register to UART_i receive buffer register is completed
Error detection	<ul style="list-style-type: none"> • Overrun error (Note 3) Generated 6.5, 7, or 8.5 clock periods after the device started receiving the next data before reading out the contents of the UART_i receive buffer register. • Framing error This error occurs when the number of stop bits set is not detected • Parity error This error occurs when if parity is enabled, the number of 1's in parity and character bits does not match the number of 1's set • Error sum flag This flag is set (= 1) when any of the overrun, framing, and parity errors is encountered

Note 1: 'n' denotes the value 00₁₆ to FF₁₆ that is set to the UART_i bit rate generator.

Note 2: f_{EXT} is input from the CLK_i pin.

Note 3: If an overrun error occurs, the UART_i receive buffer will have the next data written in. Note also that the UART_i receive interrupt request bit does not change.

Table 1.15.8. Specifications of UART Mode (2)

Item	Specification
Select function	<ul style="list-style-type: none"><li data-bbox="491 349 1426 461">• Serial data logic switch (UART2) This function is reversing logic value of transferring data. Start bit, parity bit and stop bit are not reversed.<li data-bbox="491 465 1426 577">• TXD, RXD I/O polarity switch (UART2) This function is reversing TXD port output and RXD port input. All I/O data level is reversed.

Table 1.15.9 Registers used in UART mode and the register values set

Register	Bit	Function
UiTB	0 to 8	Set transmission data (Note 1)
UiRB	0 to 8	Reception data can be read (Note 1)
	OER, FER, PER, SUM	Error flag
UiBRG	---	Set a transfer rate
UiMR	SMD2 to SMD0	Set these bits to '100 ₂ ' when transfer data is 7 bits long Set these bits to '101 ₂ ' when transfer data is 8 bits long Set these bits to '110 ₂ ' when transfer data is 9 bits long
	CKDIR	Select the internal clock or external clock
	STPS	Select the stop bit
	PRY, PRYE	Select whether parity is included and whether odd or even
	IOPOL	Select the TxD/RxD input/output polarity
UiC0	CLK0, CLK1	Select the count source for the UiBRG register
	CRS	Select CTS or RTS to use
	TXEPT	Transmit register empty flag
	CRD	Enable or disable the CTS or RTS function
	NCH	Select TxDi pin output mode (Note 2)
	CKPOL	Set to "0"
	UFORM	LSB first or MSB first can be selected when transfer data is 8 bits long. Set this bit to "0" when transfer data is 7 or 9 bits long.
UiC1	TE	Set this bit to "1" to enable transmission
	TI	Transmit buffer empty flag
	RE	Set this bit to "1" to enable reception
	RI	Reception complete flag
	U2IRS (Note 2)	Select the source of UART2 transmit interrupt
	U2RRM (Note 2)	Set to "0"
	UiLCH	Set this bit to "1" to use inverted data logic
	UiERE	Set to "0"
UiSMR	0 to 7	Set to "0"
UiSMR2	0 to 7	Set to "0"
UiSMR3	0 to 7	Set to "0"
UiSMR4	0 to 7	Set to "0"
UCON	U0IRS, U1IRS	Select the source of UART0/UART1 transmit interrupt
	U0RRM, U1RRM	Set to "0"
	CLKMD0	Invalid because CLKMD1 = 0
	CLKMD1	Set to "0"
	RCSP	Set this bit to "1" to accept as input the UART0 CTS ₀ signal from the P64 pin
	7	Set to "0"

Note 1: The bits used for transmit/receive data are as follows: Bit 0 to bit 6 when transfer data is 7 bits long; bit 0 to bit 7 when transfer data is 8 bits long; bit 0 to bit 8 when transfer data is 9 bits long.

Note 2: Set the U0C1 and U1C1 registers bit 4 to bit 5 to "0". The U0IRS, U1IRS, U0RRM and U1RRM bits are included in the UCON register.

Note 3: TxD₂ pin is N channel open-drain output. Set the U2C0 register's NCH bit to "0".

i=0 to 2

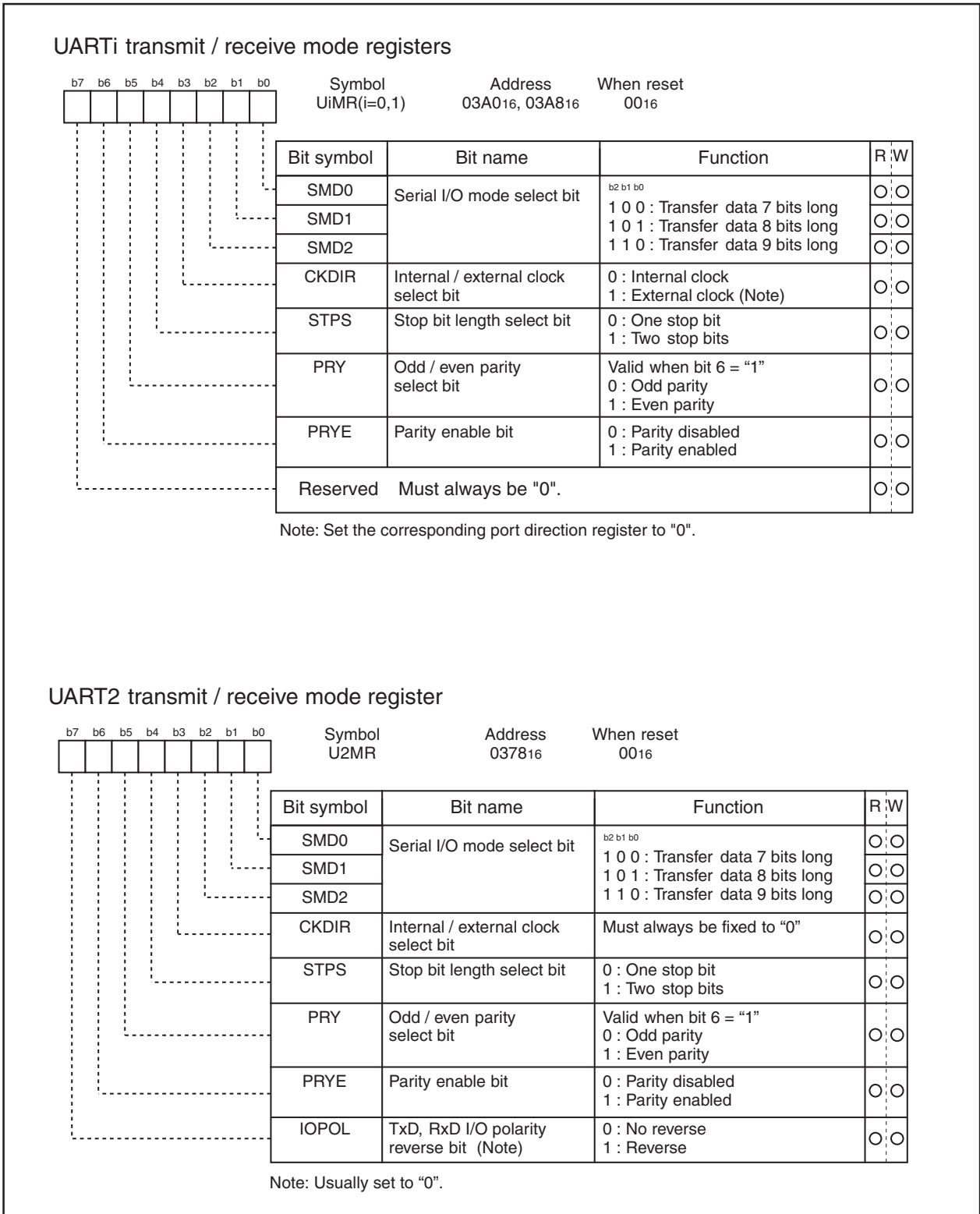

Figure 1.15.18. UARTi transmit/receive mode register in UART mode

Table 1.15.10 lists the functions of the input/output pins during UART mode. Note that for a period from when the UARTi operation mode is selected to when transfer starts, the TxDi pin outputs an “H”. (If the N-channel open-drain is selected, this pin is in floating state.)

Table 1.15.10. Input/output pin functions in UART mode

Pin name	Function	Method of selection
TxDi (P63, P67, P70)	Serial data output	
RxDi (P62, P66, P71)	Serial data input	Port P62, P66 and P71 direction register (bits 2 and 6 of address 03EE16, bit 1 of address 03EF16) = 0 (Can be used as an input port when performing transmission only)
CLKi (P61, P65, P72)	Programmable I/O port	Internal/external clock select bit (bit 3 of address 03A016, 03A816, 037816) = 0
	Transfer clock input	Internal/external clock select bit (bit 3 at address 03A016, 03A816, 037816) = 1 Port P61, P65 and P72 direction register (bits 1 and 5 of address 03EE16) = 0 (Do not use external for UART2)
CTS _i /RTS _i (P60, P64, P73)	CTS input	CTS/RTS disable bit (bit 4 of address 03A416, 03AC16, 037C16) = 0 CTS/RTS function select bit (bit 2 of address 03A416, 03AC16, 037C16) = 0 Port P60, P64 and P73 direction register (bits 0 and 4 of address 03EE16, bit 3 at address 03EF16) = 0
	RTS output	CTS/RTS disable bit (bit 4 of address 03A416, 03AC16, 037C16) = 0 CTS/RTS function select bit (bit 2 of address 03A416, 03AC16, 037C16) = 1
	Programmable I/O port	CTS/RTS disable bit (bit 4 of address 03A416, 03AC16, 037C16) = 1

Table 1.15.11. P64 pin function in UART mode

Pin function	Bit set value				
	U1C0 register		UCON register		PD6 register
	CRD	CRS	RCSP	CLKMD1	PD6_4
P64	1	—	0	0	Input: 0, Output: 1
CTS ₁	0	0	0	0	0
RTS ₁	0	1	0	0	—
CTS ₀ (Note)	0	0	1	0	0

Note: In addition to this, set the U0C0 register's CRD bit to “0” (CTS₀/RTS₀ enabled) and the U0C0 register's CRS bit to “1” (RTS₀ selected).

• Example of transmit timing when transfer data is 8 bits long (parity enabled, one stop bit)

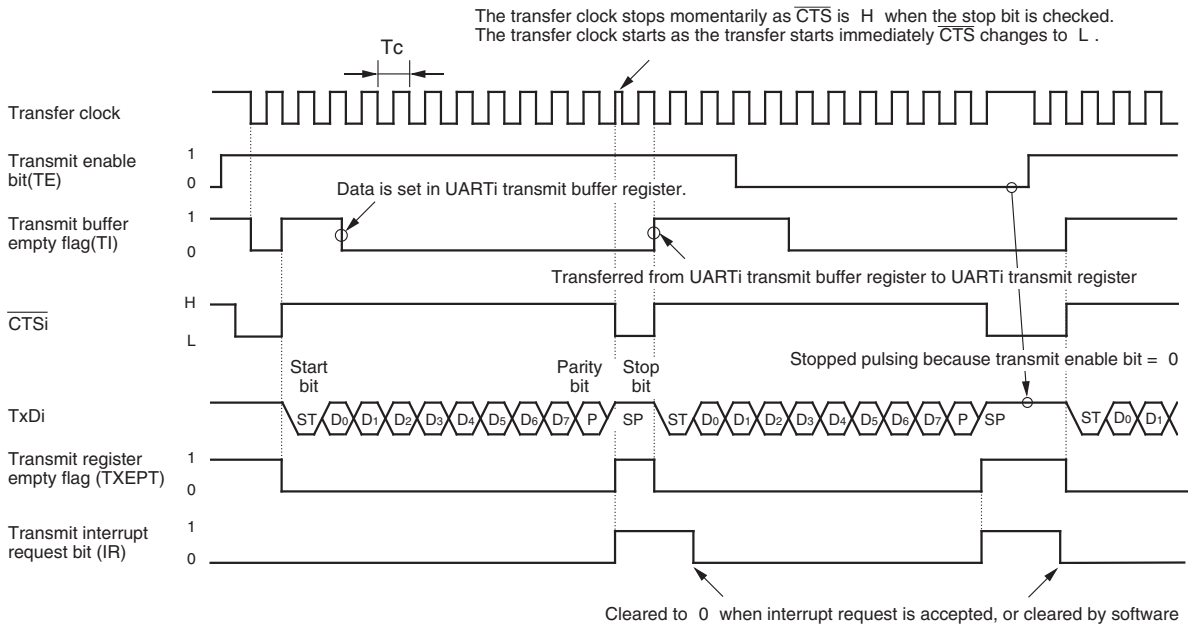

Shown in () are bit symbols.

The above timing applies to the following settings :

- * Parity is enabled.
- * One stop bit.
- * CTS function is selected.
- * Transmit interrupt cause select bit = 1 .

$$T_c = 16(n + 1) / f_i \text{ or } 16(n + 1) / f_{EXT}$$

f_i : frequency of BRGi count source (f1SIO, f2SIO, f8SIO, f32SIO)
 f_{EXT} : frequency of BRGi count source (external clock)
 n : value set to BRGi

• Example of transmit timing when transfer data is 9 bits long (parity disabled, two stop bits)

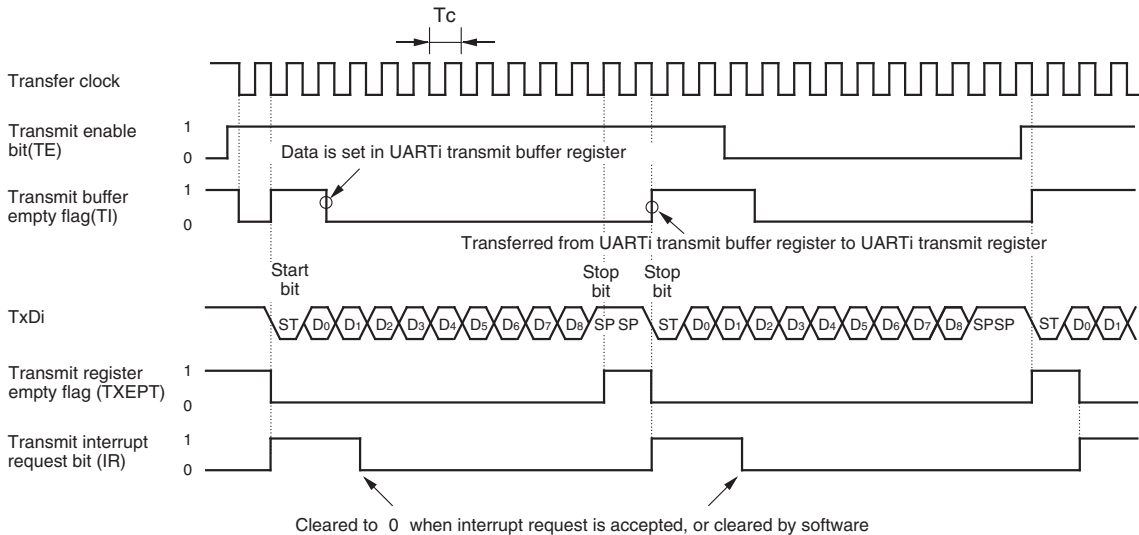

Shown in () are bit symbols.

The above timing applies to the following settings :

- * Parity is disabled
- * Two stop bits
- * CTS function is disabled
- * Transmit interrupt cause select bit = 0 .

$$T_c = 16(n + 1) / f_i \text{ or } 16(n + 1) / f_{EXT}$$

f_i : frequency of BRGi count source (f1SIO, f2SIO, f8SIO, f32SIO)
 f_{EXT} : frequency of BRGi count source (external clock)
 n : value set to BRGi

Figure 1.15.19. Typical transmit timing in UART mode (UART0, UART1)

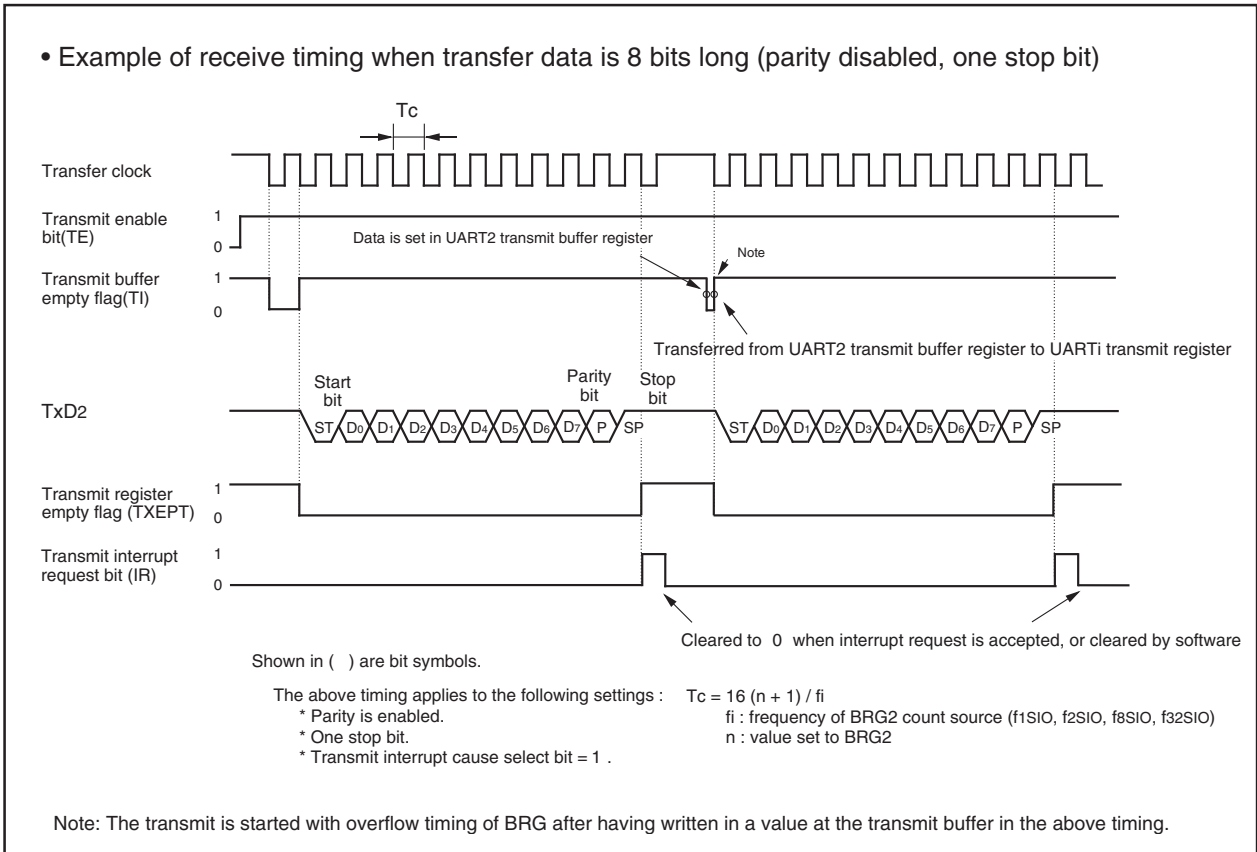

Figure 1.15.20. Typical transmit timing in UART mode (UART2)

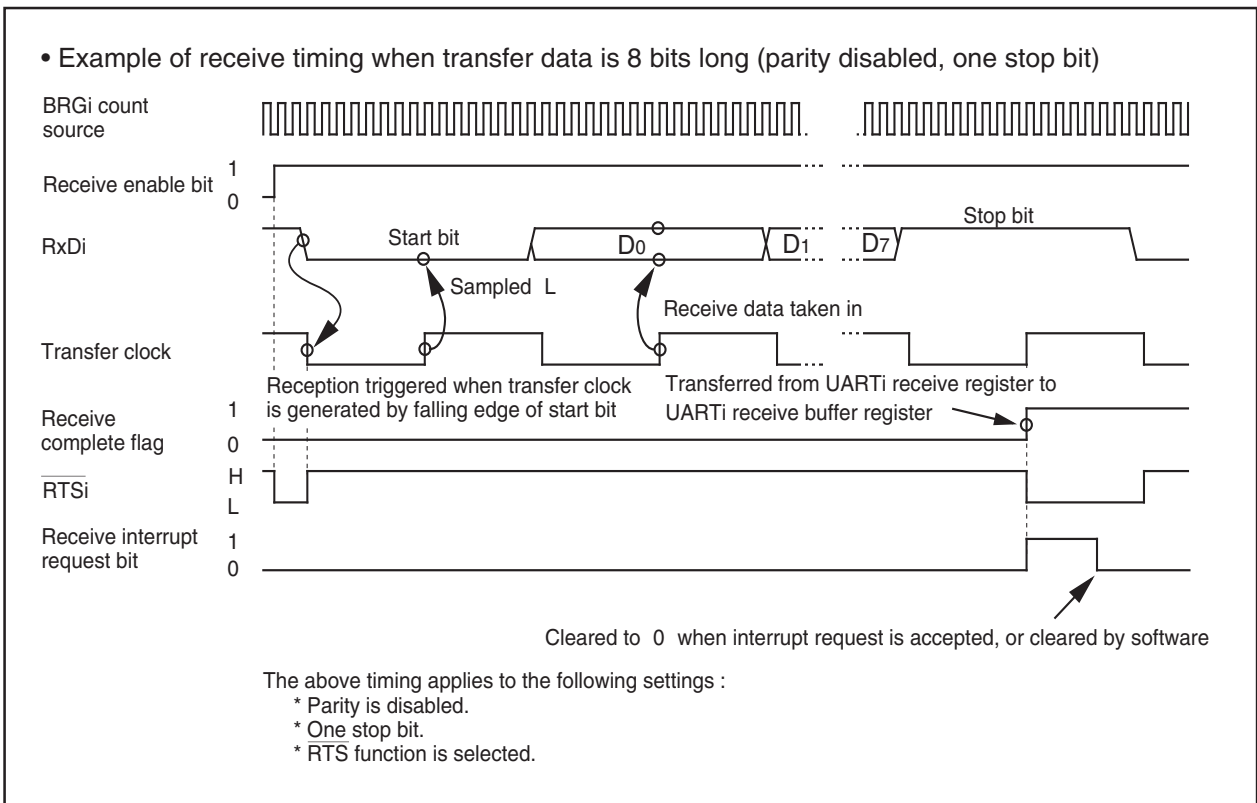

Figure 1.15.21. Typical receive timing in UART mode

(a) Function for switching serial data logic (UART2)

When the data logic select bit (bit 6 of address 037D16) is assigned 1, data is inverted in writing to the transmission buffer register or reading the reception buffer register. Figure 1.15.22 shows the example of timing for switching serial data logic.

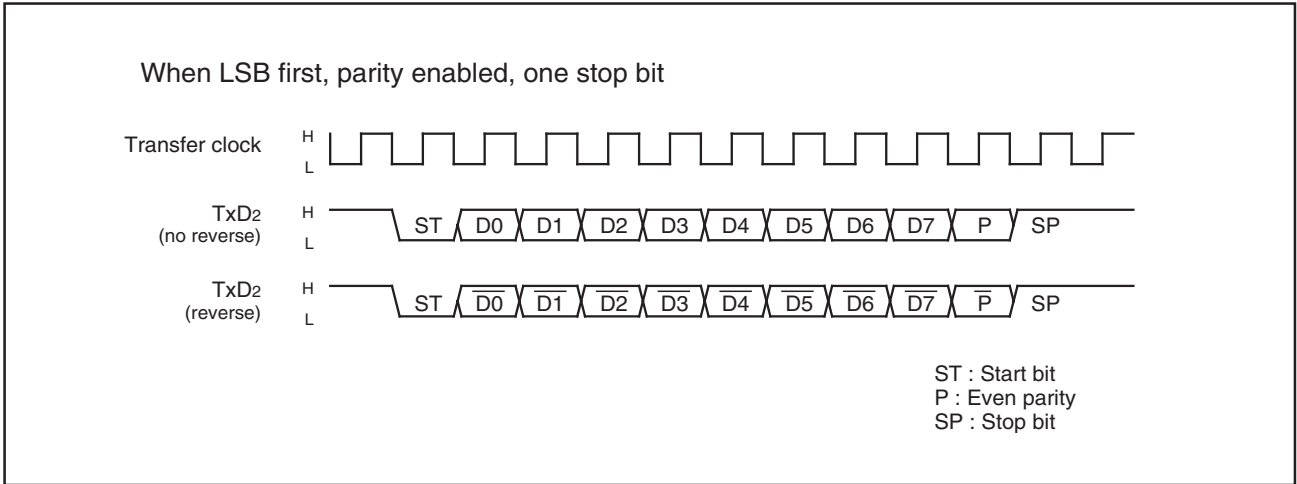

Figure 1.15.22. Timing for switching serial data logic (UART2)

(b) TxD, RxD I/O polarity reverse function (UART2)

This function reverses/inverts TxD pin output and RxD pin input. The level of any data to be input or output (including the start bit, stop bit(s), and parity bit) is reversed. Set this function to “0” (not reversed/inverted) for normal use.

(c) Bus collision detection function (UART2)

This function samples the output level of the TxD pin and the input level of the RxD pin at the rising edge of the transfer clock; if their values are different, then an interrupt request occurs. Figure 1.15.23 shows the example of detection timing of a bus collision (in UART mode).

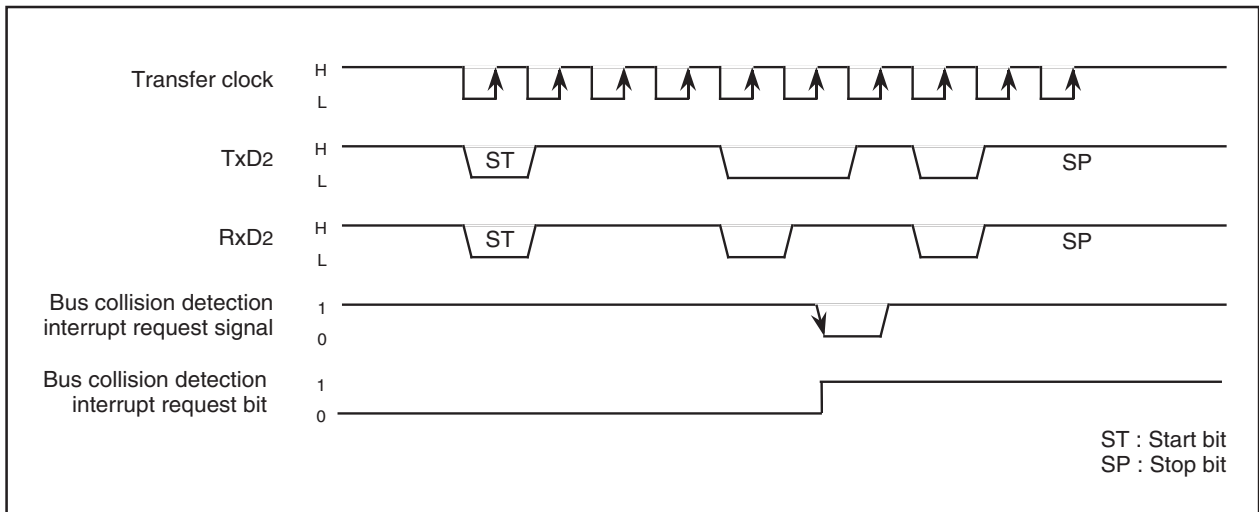

Figure 1.15.23. Detection timing of a bus collision (in UART mode)

Clock-Asynchronous Serial I/O Mode (used for SIM interface)

The SIM (Subscriber Identity Module) interface is used for connecting the microcomputer with a memory card or the like; adding some extra settings in UART2 clock-asynchronous serial I/O mode allows the user to use this function. Table 1.15.12 shows the specifications of clock-asynchronous serial I/O mode (used for SIM interface).

Table 1.15.12. Specifications of clock-asynchronous serial I/O mode (used for SIM interface)

Item	Specification
Transfer data format	<ul style="list-style-type: none"> • Transfer data 8-bit UART mode (bit 2, bit1, bit 0 of address 0378₁₆ = "1012") • One stop bit (bit 4 of address 0378₁₆ = "0") • With the direct format chosen <ul style="list-style-type: none"> - Set parity to "even" (bit 5, bit 6 of address 0378₁₆ = "112") - Set data logic to "direct" (bit 6 of address 037D₁₆ = "0") - Set transfer format to LSB (bit 7 of address 037C₁₆ = "0") • With the inverse format chosen <ul style="list-style-type: none"> - Set parity to "odd" (bit 5, bit 6 of address 0378₁₆ = "012") - Set data logic to "inverse" (bit 6 of address 037D₁₆ = "1") - Set transfer format to MSB (bit 7 of address 037C₁₆ = "1")
Transfer clock	<ul style="list-style-type: none"> • With the internal clock chosen (bit 3 of address 0378₁₆ = "0") : $f_i / 16 (n + 1)$ (Note 1) : $f_i = f_{1SIO}, f_{2SIO}, f_{8SIO}, f_{32SIO}$ (Do not set external clock)
Transmission/reception control Other settings	<ul style="list-style-type: none"> • Disable the CTS and RTS function (bit 4 of address 037C₁₆ = "1") • UART2 does not support sleep mode function. • Set transmission interrupt factor to "transmission completed" (bit 4 of address 037D₁₆ = "1")
Transmission start condition	<ul style="list-style-type: none"> • To start transmission, the following requirements must be met: <ul style="list-style-type: none"> - Transmit enable bit (bit 0 of address 037D₁₆) = "1" - Transmit buffer empty flag (bit 1 of address 037D₁₆) = "0"
Reception start condition	<ul style="list-style-type: none"> • To start reception, the following requirements must be met: <ul style="list-style-type: none"> - Reception enable bit (bit 2 of address 037D₁₆) = "1" - Detection of a start bit
Interrupt request generation timing	<ul style="list-style-type: none"> • When transmitting <ul style="list-style-type: none"> - When data transmission from the UART2 transmit register is completed (bit 4 of address 037D₁₆ = "1") • When receiving <ul style="list-style-type: none"> - When data transfer from the UART2 receive register to the UART2 receive buffer register is completed
Error detection	<ul style="list-style-type: none"> • Overrun error (see the specifications of clock-asynchronous serial I/O) (Note 2) • Framing error (see the specifications of clock-asynchronous serial I/O) • Parity error (see the specifications of clock-asynchronous serial I/O) <ul style="list-style-type: none"> - On the reception side, an "L" level is output from the TXD2 pin by use of the parity error signal output function (bit 7 of address 037D₁₆ = "1") when a parity error is detected - On the transmission side, a parity error is detected by the level of input to the RXD2 pin when a transmission interrupt occurs • The error sum flag (see the specifications of clock-asynchronous serial I/O)

Note 1: 'n' denotes the value 00₁₆ to FF₁₆ that is set to the UART2 bit rate generator.

Note 2: If an overrun error occurs, the UART2 receive buffer will have the next data written in. In addition, the UART2 receive interrupt request bit does not change.

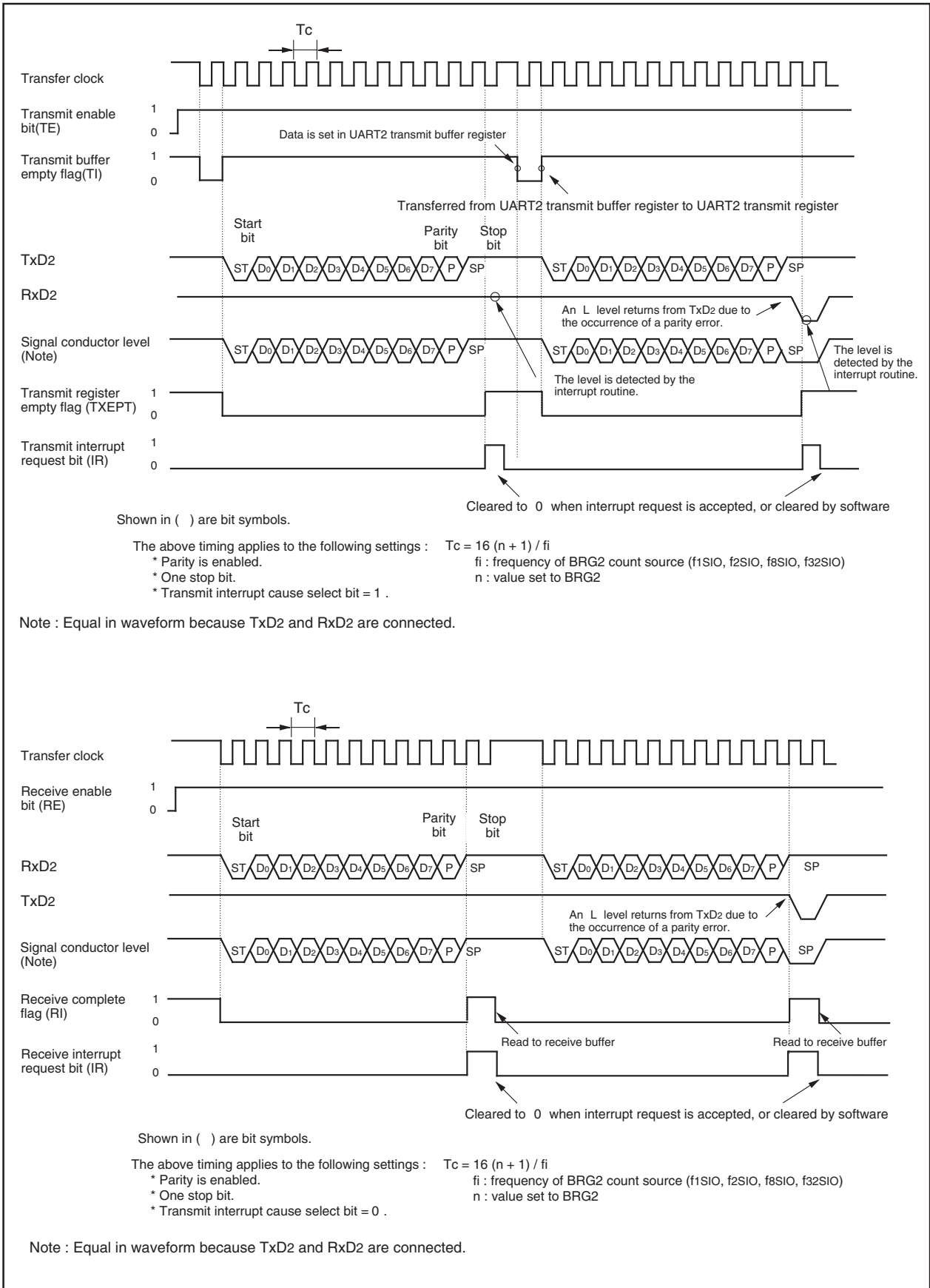

Figure 1.15.24. Typical transmit/receive timing in UART mode (used for SIM interface)

(a) Function to output a parity error signal

During reception, with the error signal output enable bit (bit 7 of address 037D16) assigned "1", you can output an "L" level from the TxD2 pin when a parity error is detected. And during transmission, comparing with the case in which the error signal output enable bit (bit 7 of address 037D16) is assigned "0", the transmission completion interrupt occurs in the half cycle later of the transfer clock. Therefore parity error signals can be detected by a transmission completion interrupt program. Figure 1.15.25 shows the output timing of the parity error signal.

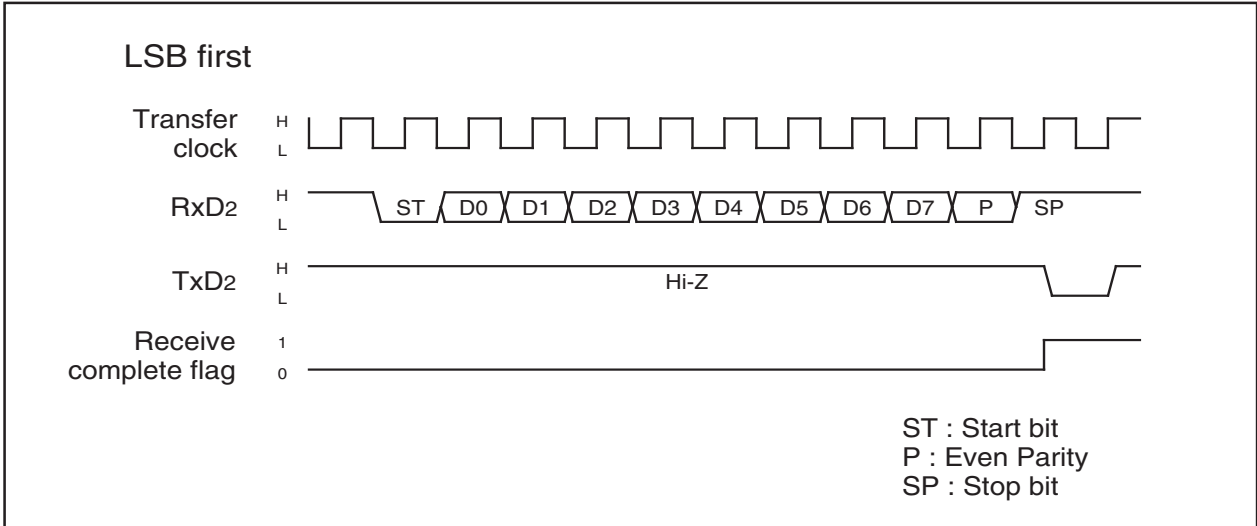

Figure 1.15.25. Output timing of the parity error signal

(b) Direct format/inverse format

Connecting the SIM card allows you to switch between direct format and inverse format. If you choose the direct format, D0 data is output from TxD2. If you choose the inverse format, D7 data is inverted and output from TxD2.

Figure 1.15.26 shows the SIM interface format.

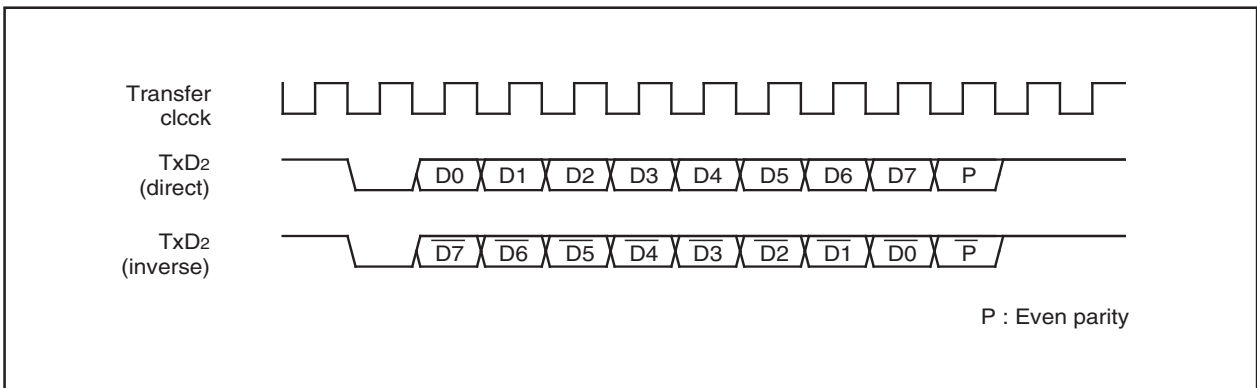

Figure 1.15.26. SIM interface format

Figure 1.15.27 shows the example of connecting the SIM interface. Connect TXD2 and RXD2 and apply pull-up.

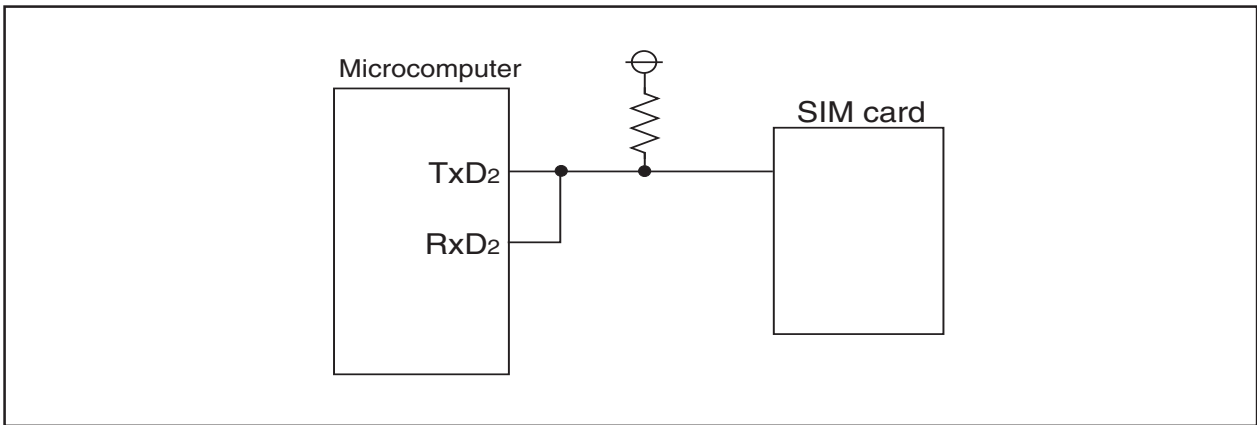

Figure 1.15.27. Connecting the SIM interface

UART2 Special Mode Register

The UART2 special mode register (address 037716) is used to control UART2 in various ways.

Bit 0 of the UART2 special mode register are used as the I²C mode select bit.

Setting “1” in the I²C mode select bit (bit 0) goes the circuit to achieve the I²C bus (simplified I²C bus) interface effective.

Table 1.15.13 shows the relation between the I²C mode select bit and respective control workings.

Since this function uses clock-synchronous serial I/O mode, set this bit to “0” in UART mode.

Table 1.15.13. Features in I²C mode

	Function	Normal mode	I ² C mode (Note 1)
1	Factor of interrupt number 10 (Note 2, 4)	Bus collision detection	Start condition detection or stop condition detection
2	Factor of interrupt number 15 (Note 2)	UART2 transmission	No acknowledgment detection (NACK)
3	Factor of interrupt number 16 (Note 2)	UART2 reception	Acknowledgment detection (ACK)
4	UART2 transmission output delay	Not delayed	Delayed
5	P ₇₀ at the time when UART2 is in use	TxD2 (output)	SDA (input/output) (Note 3)
6	P ₇₁ at the time when UART2 is in use	RxD2 (input)	SCL (input/output)
7	P ₇₂ at the time when UART2 is in use	CLK2	P ₇₂
8	DMA1 factor at the time when 1101 is assigned to the DMA request factor selection bits	UART2 reception	Acknowledgment detection (ACK)
9	Noise filter width	15ns	200ns
10	Reading P ₇₁	Reading the terminal when 0 is assigned to the direction register	Reading the terminal regardless of the value of the direction register
11	Initial value of UART2 output	H level (when 0 is assigned to the CLK polarity select bit)	The value set in latch P ₇₀ when the port is selected (Note 3)

Note 1: Make the settings given below when I²C mode is in use.

Set 0 1 0 in bits 2, 1, 0 of the UART2 transmission/reception mode register.

Disable the RTS/CTS function. Choose the MSB First function.

Note 2: Follow the steps given below to switch from a factor to another.

1. Disable the interrupt of the corresponding number.
2. Switch from a factor to another.
3. Reset the interrupt request flag of the corresponding number.
4. Set an interrupt level of the corresponding number.

Note 3: Set an initial value of SDA transmission output when serial I/O is invalid.

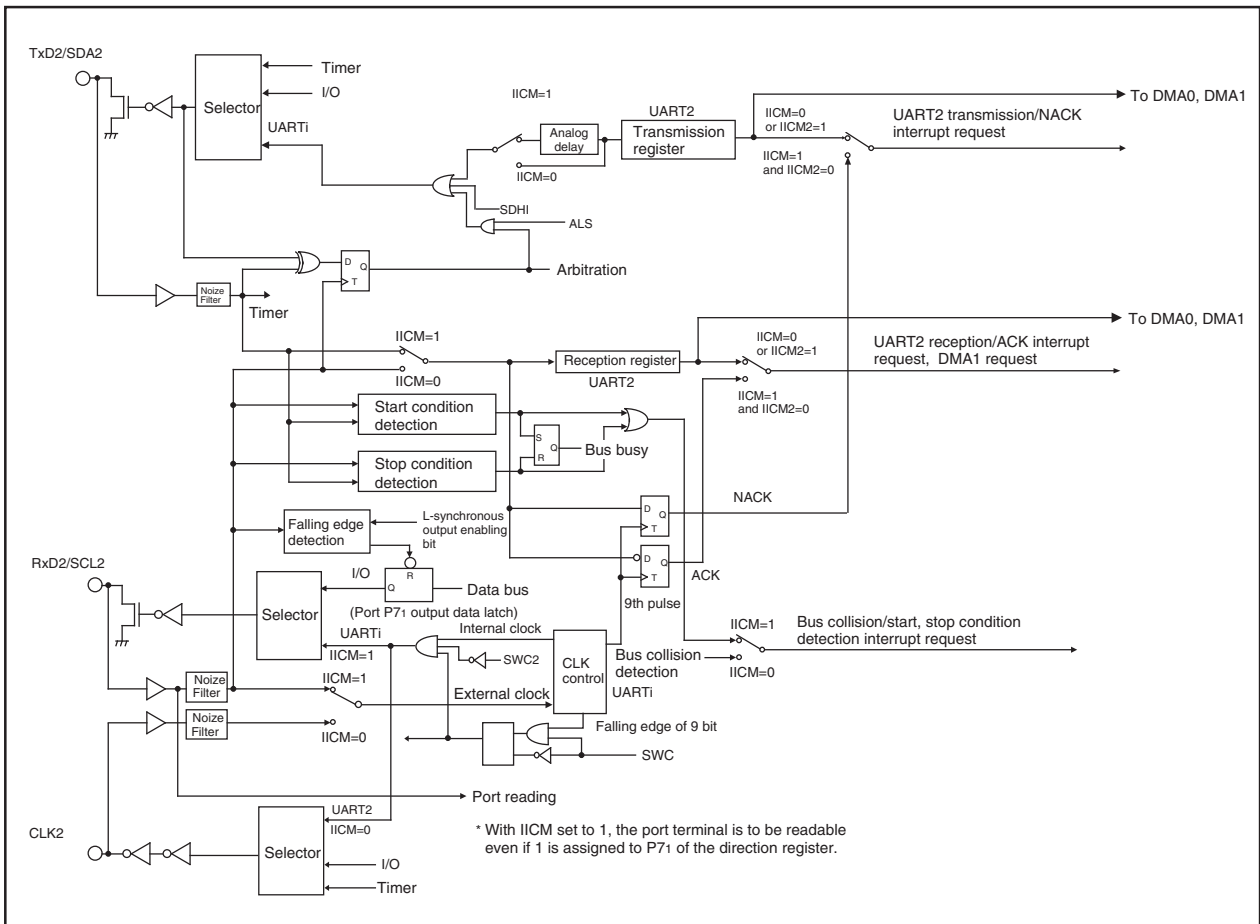

Figure 1.15.28. Functional block diagram for I²C mode

Figure 1.15.28 shows the functional block diagram for I²C mode.

Setting “1” in the I2C mode select bit (IICM) causes ports to work as data transmission-reception terminal SDA_i, clock input-output terminal SCL_i, and port respectively. A delay circuit is added to the SDA2 transmission output, so the SDA2 output changes after SCL2 fully goes to “L”.

An attempt to read Port (SCL2) results in getting the terminal’s level regardless of the content of the port direction register. The initial value of SDA2 transmission output in this mode goes to the value set in port. The interrupt factors of the bus collision detection interrupt, UART2 transmission interrupt, and of UART2 reception interrupt turn to the start/stop condition detection interrupt, acknowledgment non-detection interrupt, and acknowledgment detection interrupt respectively.

The start condition detection interrupt refers to the interrupt that occurs when the falling edge of the SDA2 terminal is detected with the SCL2 terminal staying “H”. The stop condition detection interrupt refers to the interrupt that occurs when the rising edge of the SDA2 terminal is detected with the SCL2 terminal staying “H”. The bus busy flag (bit 2 of the UART2 special mode register) is set to “1” by the start condition detection, and set to “0” by the stop condition detection.

The acknowledgment non-detection interrupt refers to the interrupt that occurs when the SDA2 terminal level is detected still staying “H” at the rising edge of the 9th transmission clock. The acknowledgment detection interrupt refers to the interrupt that occurs when SDA2 terminal’s level is detected already went to “L” at the 9th transmission clock. Also, assigning (UART2 reception) to the DMA1 request factor select bits provides the means to start up the DMA transfer by the effect of acknowledgment detection.

Bit 1 of the UART2 special mode register is used as the arbitration lost detecting flag control bit. Arbitration means the act of detecting the nonconformity between transmission data and SDA2 terminal data at the timing of the SCL2 rising edge. This detecting flag is located at bit 11 of the UART2 reception buffer register, and “1” is set in this flag when nonconformity is detected. Use the arbitration lost detecting flag control bit to choose which way to use to update the flag, bit by bit or byte by byte. When setting this bit to “1” and updated the flag byte by byte if nonconformity is detected, the arbitration lost detecting flag is set to “1” at the falling edge of the 9th transmission clock.

If update the flag byte by byte, must judge and clear (“0”) the arbitration lost detecting flag after completing the first byte acknowledge detect and before starting the next one byte transmission.

Bit 3 of the UART2 special mode register is used as SCL2- and L-synchronous output enable bit. Setting this bit to “1” goes the port data register to “0” in synchronization with the SCL2 terminal level going to “L”.

Some other functions added are explained here. Figure 1.15.29 shows their workings.

Bit 4 of the UART2 special mode register is used as the bus collision detect sampling clock select bit. The bus collision detect interrupt occurs when the RxD2 level and TxD2 level do not match, but the nonconformity is detected in synchronization with the rising edge of the transfer clock signal if the bit is set to "0". If this bit is set to "1", the nonconformity is detected at the timing of the overflow of timer Aj rather than at the rising edge of the transfer clock.

Bit 5 of the UART2 special mode register is used as the auto clear function select bit of transmit enable bit. Setting this bit to "1" automatically resets the transmit enable bit to "0" when "1" is set in the bus collision detect interrupt request bit (nonconformity).

Bit 6 of the UART2 special mode register is used as the transmit start condition select bit. Setting this bit to "1" starts the TxD transmission in synchronization with the falling edge of the RxD terminal.

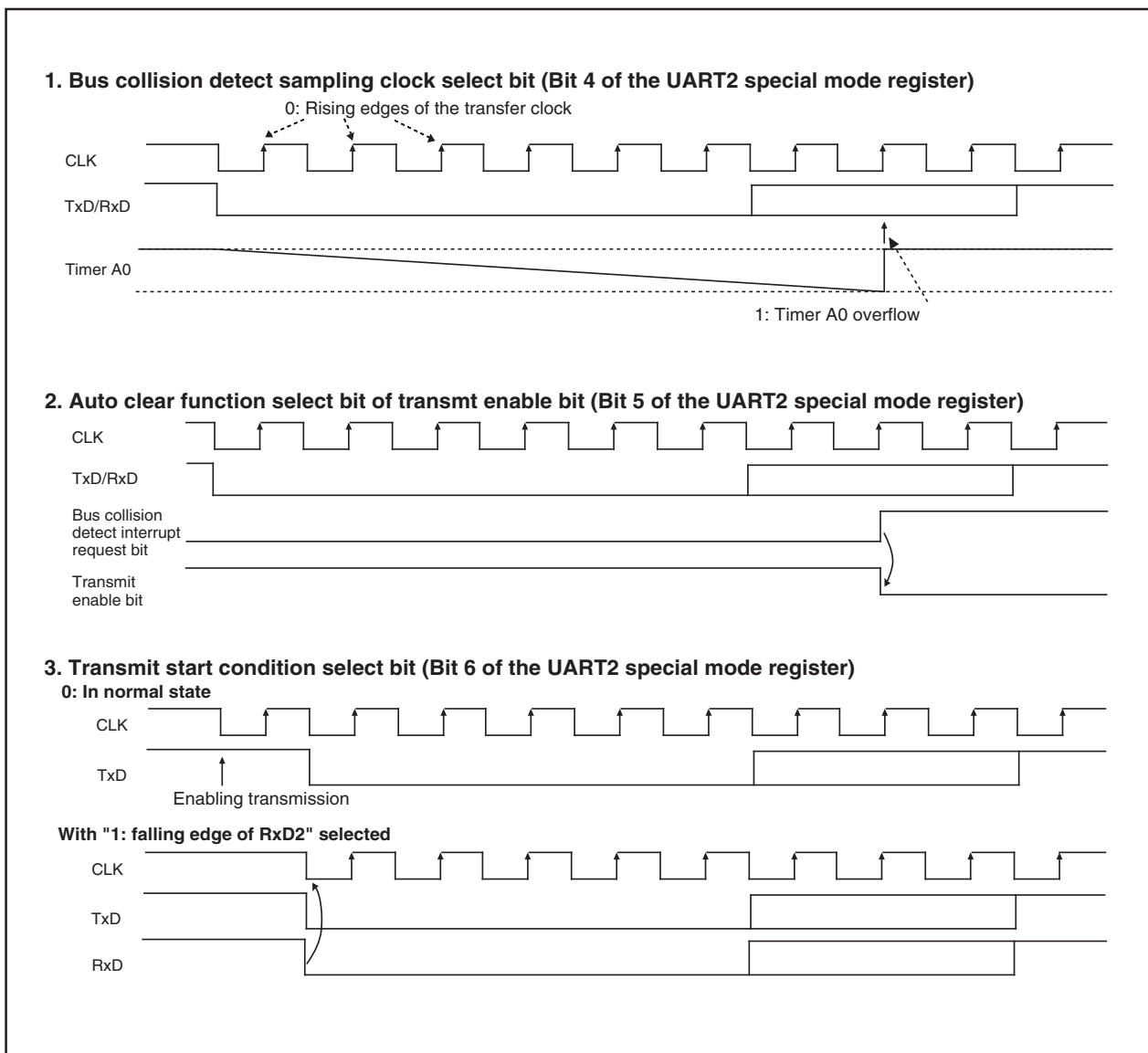

Figure 1.15.29. Some other functions added

UART2 Special Mode Register 2

UART_i special mode register 2 (address 037616) is used to further control UART2 in I²C mode.

Bit 0 of the UART2 special mode register 2 (address 037616) is used as the I²C mode select bit 2. Table 1.15.14 shows the types of control to be changed by I²C mode select bit 2 when the I²C mode select bit is set to "1". Table 1.15.15 shows the timing characteristics of detecting the start condition and the stop condition.

Table 1.15.14. Functions changed by I²C mode select bit 2

	Function	IICM2 = 0	IICM2 = 1
1	Factor of interrupt number 15	No acknowledgment detection (NACK)	UART2 transmission (the rising edge of the final bit of the clock)
2	Factor of interrupt number 16	Acknowledgment detection (ACK)	UART2 reception (the falling edge of the final bit of the clock)
3	DMA1 factor at the time when 1101 is assigned to the DMA request factor selection bits.	Acknowledgment detection (ACK)	UART2 reception (the falling edge of the final bit of the clock)
4	Timing for transferring data from the UART2 reception shift register to the reception buffer.	The rising edge of the final bit of the reception clock	The falling edge of the final bit of the reception clock
5	Timing for generating a UART2 reception/ACK interrupt request	The rising edge of the final bit of the reception clock	The falling edge of the final bit of the reception clock

Table 1.15.15. Timing characteristics of detecting the start condition and the stop condition (Note 1)

3 to 6 cycles < duration for setting-up (Note)
3 to 6 cycles < duration for holding (Note)

Note: Cycles is in terms of the input oscillation frequency $f(X_{IN})$ of the main clock.

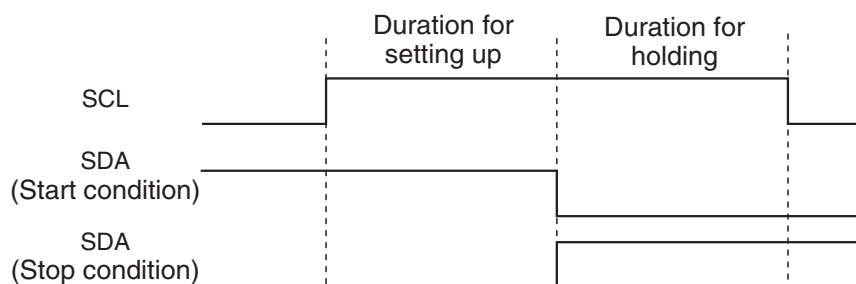

Bit 3 of the UART_i special mode register 2 are used as the SDA_i output stop bit. Setting this bit to “1” causes an arbitration loss to occur, and the SDA_i pin turns to high-impedance state at the instant when the arbitration lost detecting flag is set to “1”.

Bit 1 of the UART2 special mode register 2 are used as the clock synchronization bit. With this bit set to “1” at the time when the internal SCL2 is set to “H”, the internal SCL2 turns to “L” if the falling edge is found in the SCL2 pin; and the baud rate generator reloads the set value, and start counting within the “L” interval.

When the internal SCL2 changes from “L” to “H” with the SCL2 pin set to “L”, stops counting the baud rate generator, and starts counting it again when the SCL2 pin turns to “H”. Due to this function, the UART2 transmission-reception clock becomes the logical product of the signal flowing through the internal SCL2 and that flowing through the SCL2 pin. This function operates over the period from the moment earlier by a half cycle than falling edge of the UART2 first clock to the rising edge of the ninth bit. To use this function, choose the internal clock for the transfer clock.

Bit 2 of the UART2 special mode register 2 are used as the SCL2 wait output bit. Setting this bit to “1” causes the SCL2 pin to be fixed to “L” at the falling edge of the ninth bit of the clock. Setting this bit to “0” frees the output fixed to “L”.

Bit 4 of the UART2 special mode register 2 are used as the UART2 initialization bit. Setting this bit to “1”, and when the start condition is detected, the microcomputer operates as follows.

(1) The transmission shift register is initialized, and the content of the transmission register is transferred to the transmission shift register. This starts transmission by dealing with the clock entered next as the first bit. The UART2 output value, however, doesn't change until the first bit data is output after the entrance of the clock, and remains unchanged from the value at the moment when the microcomputer detected the start condition.

(2) The reception shift register is initialized, and the microcomputer starts reception by dealing with the clock entered next as the first bit.

(3) The SCL2 wait output bit turns to “1”. This turns the SCL2 pin to “L” at the falling edge of the ninth bit of the clock.

Starting to transmit/receive signals to/from UART2 using this function doesn't change the value of the transmission buffer empty flag. To use this function, choose the external clock for the transfer clock.

Bit 5 of the UART2 special mode register 2 are used as the SCL2 pin wait output bit 2. Setting this bit to “1” with the serial I/O specified allows the user to forcibly output an “1” from the SCL2 pin even if UART2 is in operation. Setting this bit to “0” frees the “L” output from the SCL2 pin, and the UART2 clock is input/output.

Bit 6 of the UART2 special mode register 2 are used as the SDA2 output disable bit. Setting this bit to “1” forces the SDA2 pin to turn to the high-impedance state. Refrain from changing the value of this bit at the rising edge of the UART2 transfer clock. There can be instances in which arbitration lost detecting flag is turned on.

UART2 Special Mode Register 3

Bit 1 of UART2 special mode register 3 (address 037516) are used to clock phase set bit. Figure 1.15.9 shows UART2 special mode register 3.

When both the IIC mode select bit (bit 0 of UART2 special mode select register) and the IIC mode select bit 2 (bit 0 of U2SMR2 register) are "1", functions changed by these bits are shown in table 1.15.16 and figure 1.15.30.

Bits 5 to 7 of UART2 special mode register 3 are SDA digital delay setting bits. By setting these bits, it is possible to turn the SDA delay OFF or set the BRG count source delay to 2 to 8 cycles.

Table 1.15.16. Functions changed by clock phase set bits

Function	CKPH = 0, IICM = 1, IICM2 = 1	CKPH = 1, IICM = 1, IICM2 = 1
SCL initial and last value	Initial value = H, last value = L	Initial value = L, last value = L
Transfer interrupt factor	Rising edge of 9th bit	Falling edge of 10th bit
Data transfer times from UART receive shift register to receive buffer register	Falling edge of 9th bit	Two times :falling edge of 9th bit and rising edge of 9th bit

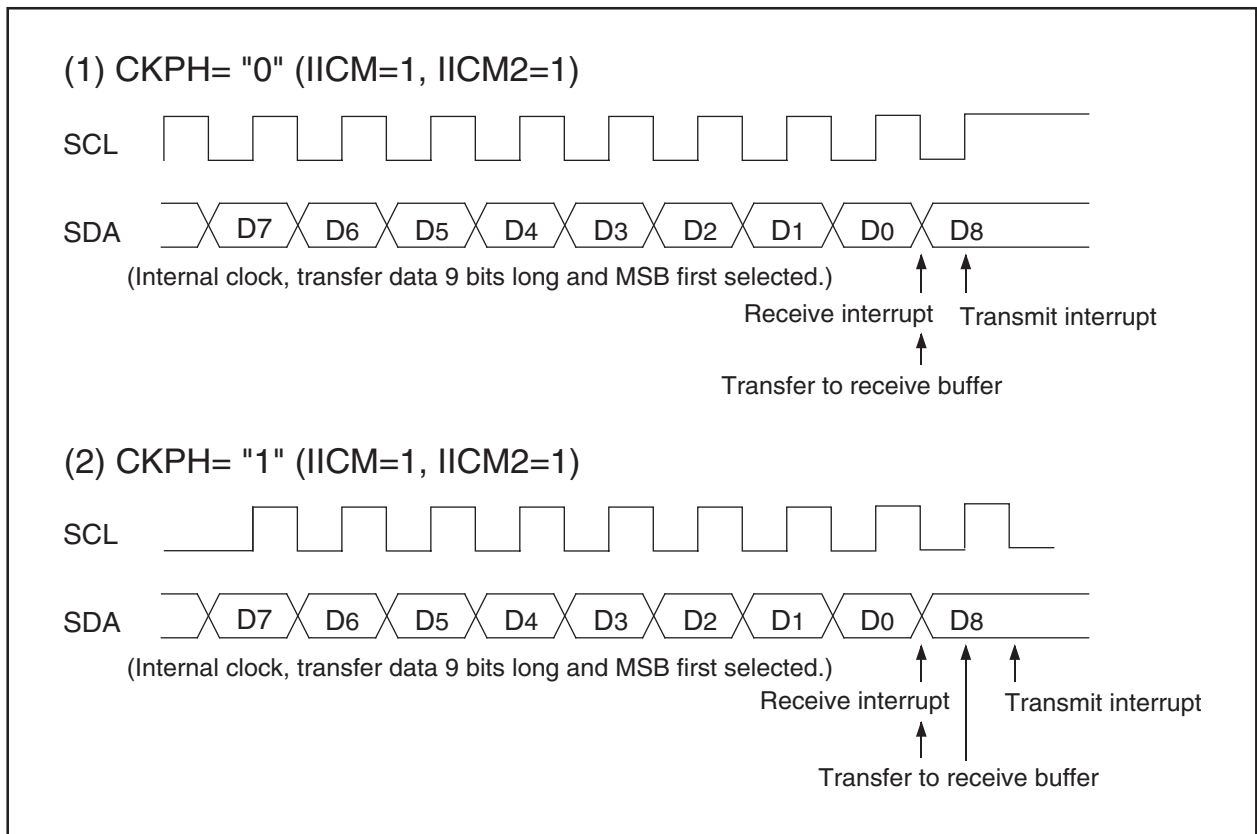

Figure 1.15.30. Functions changed by clock phase set bits

UART2 Special Mode Register 4

Bit 0 of UART2 special mode register 4 (address 037416) are used to start condition generate bit. When the SCL, SDA output select bit (bit 3 of U2SMR4 register) is "1" and this bit is "1", then the start condition is generated.

Bit 1 of UART2 special mode register 4 are used to restart condition generate bit.

When the SCL, SDA output select bit (bit 3 of U2SMR4 register) is "1" and this bit is "1", then the restart condition is generated.

Bit 2 of UART2 special mode register 4 are used to stop condition generate bit.

When the SCL, SDA output select bit (bit 3 of U2SMR4 register) is "1" and this bit is "1", then the stop condition is generated.

Bit 3 of UART2 special mode register 4 are used to SCL, SDA output select bit.

Functions changed by these bits are shown in table 1.15.17 and figure 1.15.31.

Bit 4 of UART2 special mode register 4 are used to ACK data bit.

When the SCL, SDA output select bit (bit 3 of U2SMR4 register) is "0" and the ACK data output enable bit (bit 5 of U2SMR4 register) is "1", then the content of ACK data bit is output to SDA pin.

Bit 5 of UART2 special mode register 4 are used to ACK data output enable bit.

When the SCL, SDA output select bit (bit 3 of U2SMR4 register) is "0" and this bit is "1", then the content of ACK data bit is output to SDA pin.

Bit 6 of UART2 special mode register 4 are used to SCL output stop bit.

When this bit is "1", SCL output is stopped at stop condition detection. (Hi-impedance status).

Bit 7 of UART2 special mode register 4 are used to SCL wait output bit.

When this bit is "1", SCL output is fixed to "L" at falling edge of 10th bit of clock. When this bit is "0", SCL output fixed to "L" is released.

Table 1.15.17. Functions changed by SCL, SDA output select bit

Function	STSPSEL = 0	STSPSEL = 1
SCL, SDA output	Output of SI/O control circuit	Output of start/stop condition control circuit
Start/stop condition interrupt factor	Start/stop condition detection	Completion of start/stop condition generation

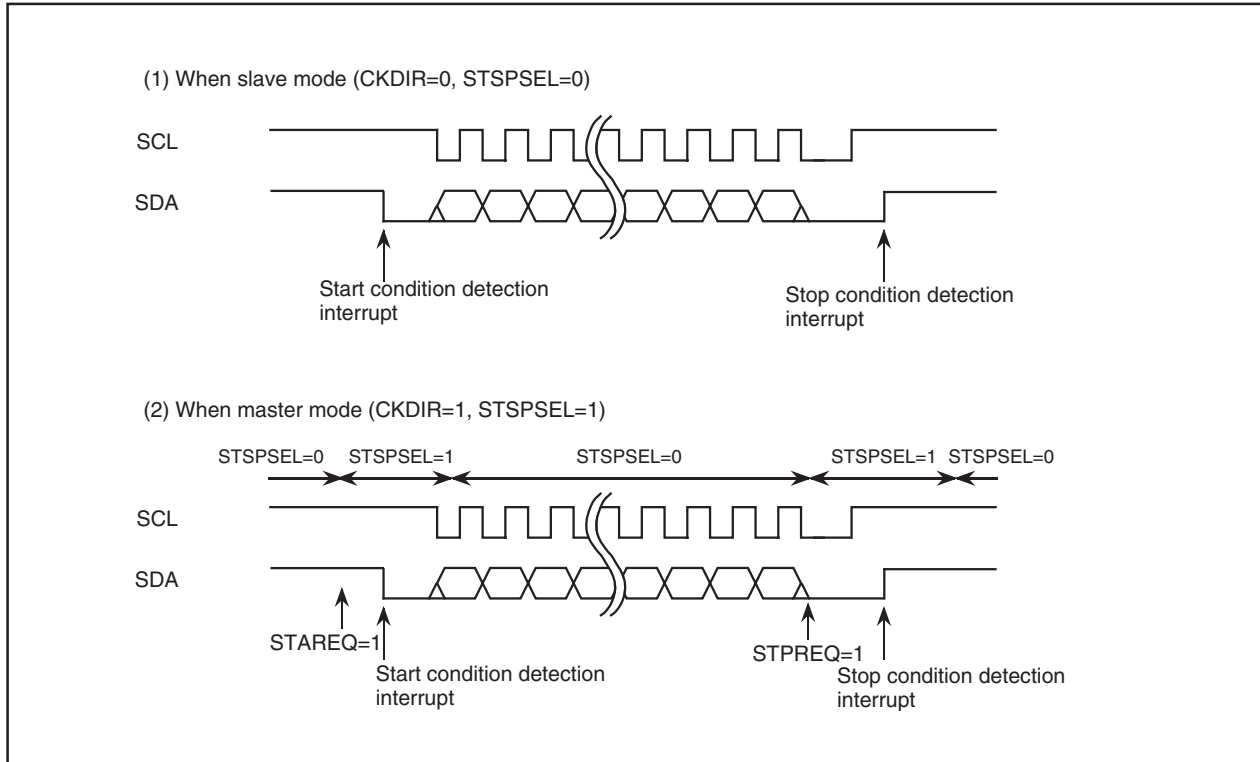

Figure 1.15.31 Functions changed by SCL, SDA output select bit

Serial Interface Special Function

UARTi can control communications on the serial bus (Figure 1.15.32). The master outputting the transfer clock transfers data to the slave inputting the transfer clock. In this case, in order to prevent a data collision on the bus, the master floats the output pin of other slaves/masters using the SSi input pins.

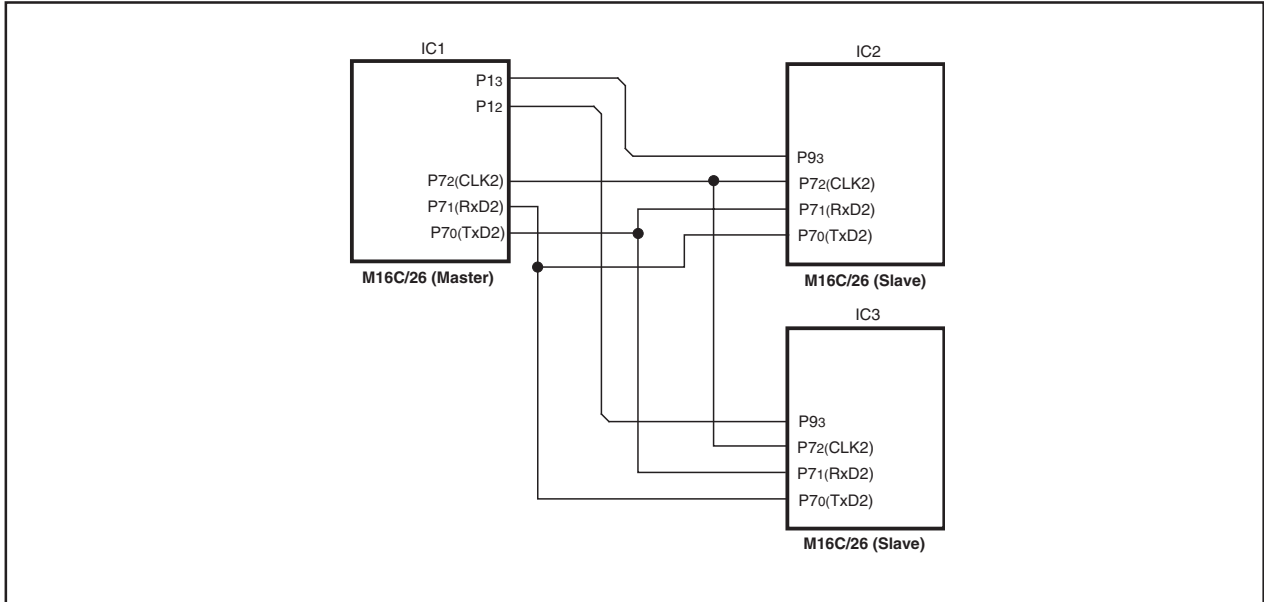

Figure 1.15.32. Programmable serial bus communication control example

• Clock Phase Setting

With bit 1 of UART2 special mode register 3 (addresses 036D₁₆, 0371₁₆ and 0375₁₆) and bit 6 of UART2 transmission-reception control register 0 (addresses 03A4₁₆, 02AC₁₆ and 037C₁₆), four combinations of transfer clock phase and polarity can be selected.

Bit 6 of UART2 transmission-reception control register 0 sets transfer clock polarity, whereas bit 1 of U2SMR3 register sets transfer clock phase.

Transfer clock phase and polarity must be the same between the master and slave involved in the transfer.

(a) Master (Internal Clock)

Figure 1.15.33 shows the transmission and reception timing.

(b) Slave (External Clock)

- Figure 1.15.34 shows the timing when bit 1 of address 0375₁₆)="0"
- Figure 1.15.35 shows the timing when bit 1 of address 0375₁₆)="1"

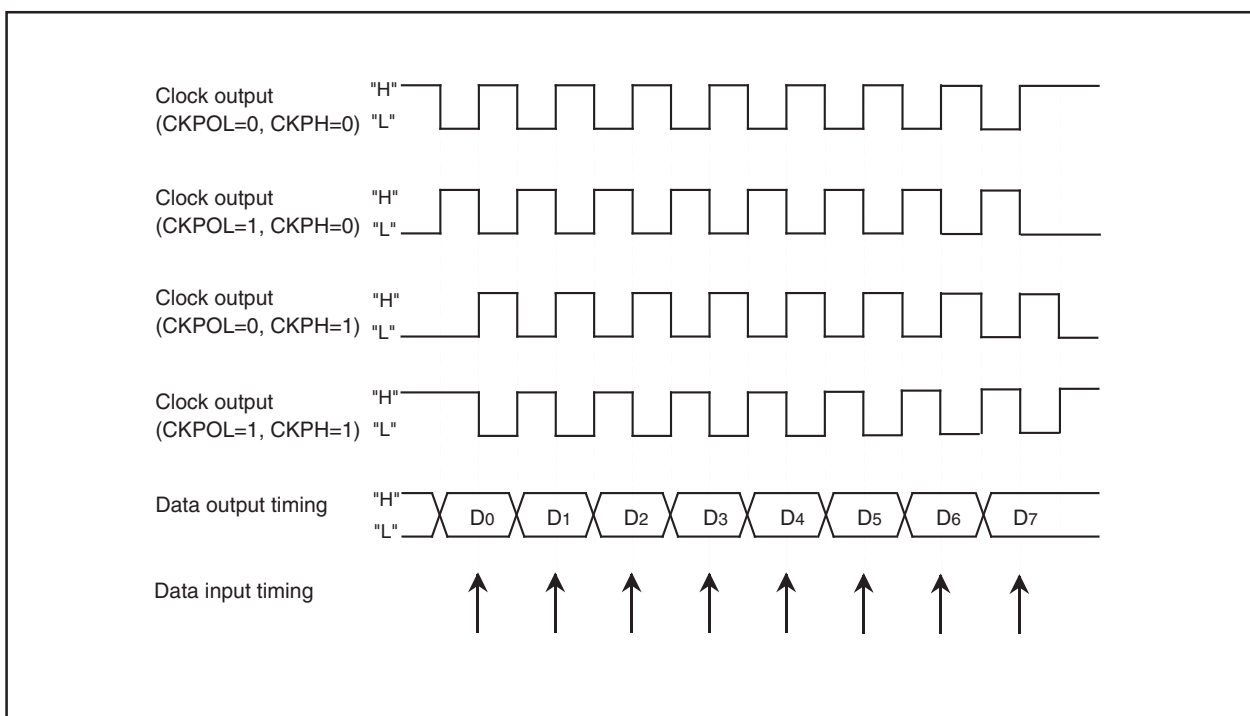

Figure 1.15.33. The transmission and reception timing in master mode (internal clock)

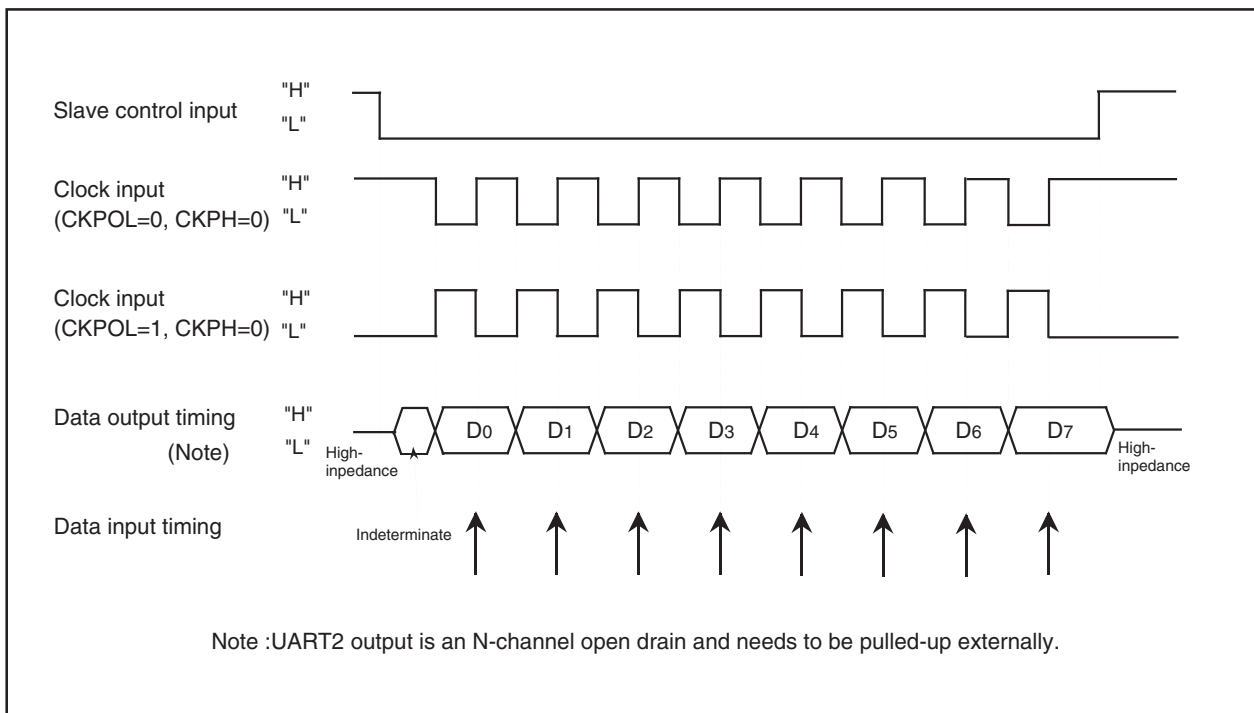

Figure 1.15.34. The transmission and reception timing (CKPH=0) in slave mode (external clock)

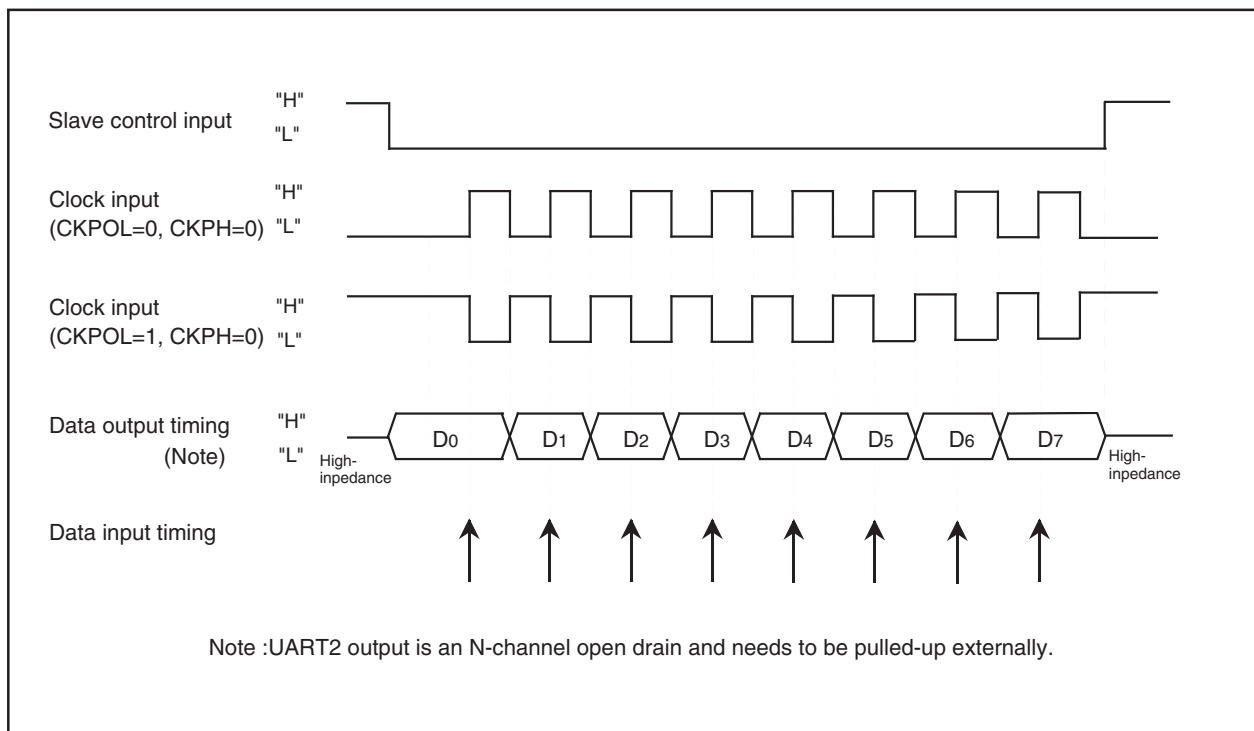

Figure 1.15.35. The transmission and reception timing (CKPH=1) in slave mode (external clock)

A-D Converter

The A-D converter consists of one 10-bit successive approximation A-D converter circuit with a capacitive coupling amplifier. Pins P100 to P107 also function as the analog signal input pins AN0 to AN7. The direction registers of these pins for A-D conversion must therefore be set to input. The Vref connect bit (bit 5 at address 03D716) can be used to isolate the resistance ladder of the A-D converter from the reference voltage input pin (VREF) when the A-D converter is not used. Doing so stops any current flowing into the resistance ladder from VREF, reducing the power dissipation. When using the A-D converter, start A-D conversion only after setting bit 5 of 03D716 to connect VREF.

The result of A-D conversion is stored in the A-D registers of the selected pins. When set to 10-bit precision, the low 8 bits are stored in the even addresses and the high 2 bits in the odd addresses. When set to 8-bit precision, the low 8 bits are stored in the even addresses. Table 1.16.1 shows the performance of the A-D converter. Figure 1.16.1 shows the block diagram of the A-D converter, and Figures 1.16.2 and 1.16.3 show the A-D converter-related registers.

Table 1.16.1. Performance of A-D converter

Item	Performance
Method of A-D conversion	Successive approximation (capacitive coupling amplifier)
Analog input voltage (Note 1)	0V to AVCC (VCC)
Operating clock fAD (Note 2)	fAD, fAD/2, fAD/3, fAD/4, fAD/6, or fAD/12 where fAD=f(XIN)
Resolution	8-bit or 10-bit (selectable)
Integral nonlinearity error	When AVCC = VREF = 5V <ul style="list-style-type: none"> • With 8-bit resolution: ±2LSB • With 10-bit resolution: ±3LSB When AVCC = VREF = 3.3V <ul style="list-style-type: none"> • With 8-bit resolution: ±2LSB • With 10-bit resolution: ±5LSB
Operating modes	One-shot mode, repeat mode, single sweep mode, repeat sweep mode 0, and repeat sweep mode 1
Analog input pins A-D conversion start condition	8pins (AN0 to AN7) <ul style="list-style-type: none"> • Software trigger A-D conversion starts when the A-D conversion start flag changes to "1" • External trigger (can be retrigged) A-D conversion starts when the A-D conversion start flag is "1" and the ADTRG/P15 input (shared with INT3) changes from "H" to "L"
Conversion speed per pin	<ul style="list-style-type: none"> • Without sample and hold function 8-bit resolution: 49 fAD cycles, 10-bit resolution: 59 fAD cycles • With sample and hold function 8-bit resolution: 28 fAD cycles, 10-bit resolution: 33 fAD cycles

Note 1: Does not depend on use of sample and hold function.

Note 2: Divide the fAD if f(XIN) exceeds 10MHz, and make φAD frequency equal to or less than 10MHz.

Without sample and hold function, set the φAD frequency to 250kHz min.

With the sample and hold function, set the φAD frequency to 1MHz min.

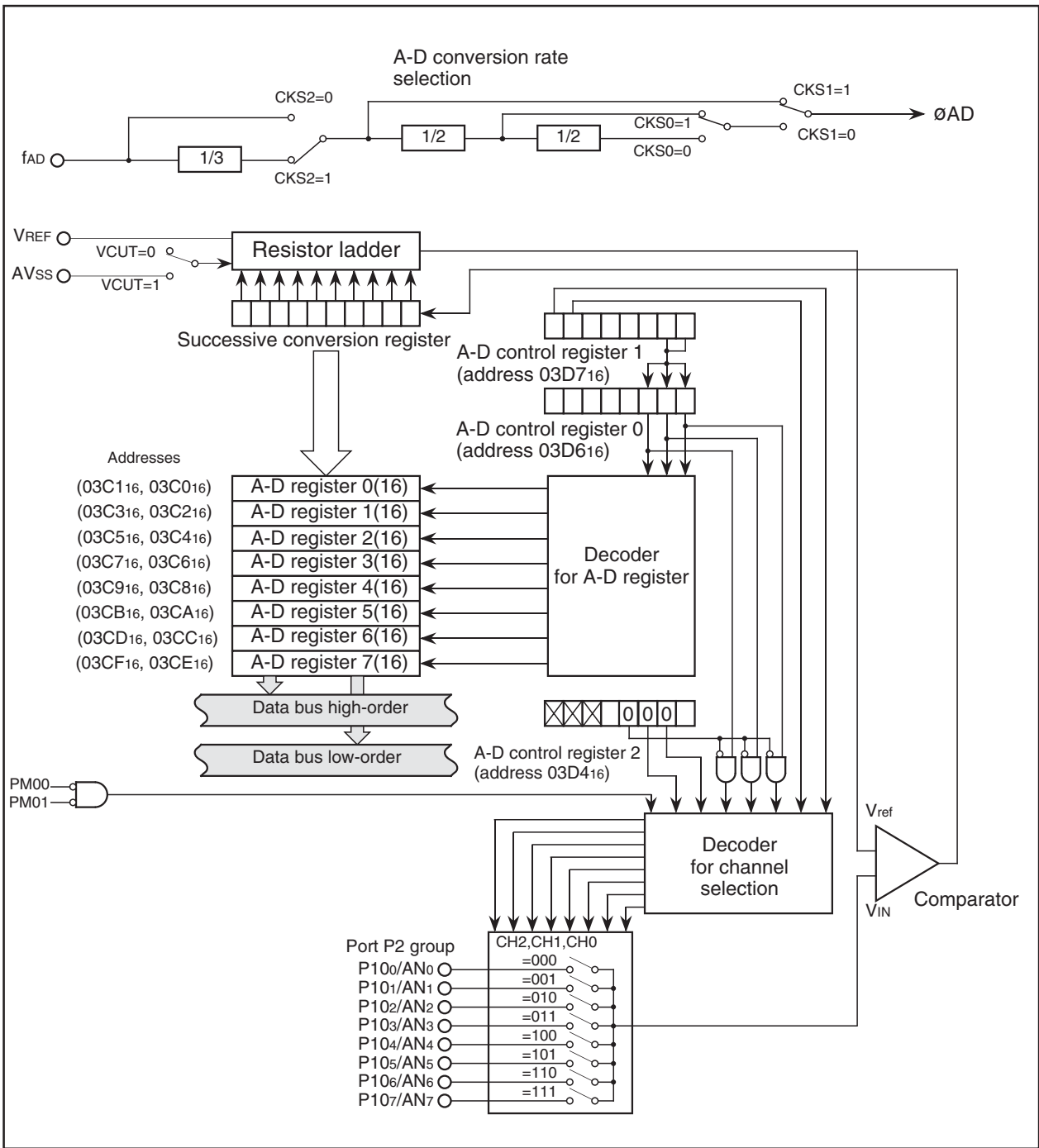

Figure 1.16.1. Block diagram of A-D converter

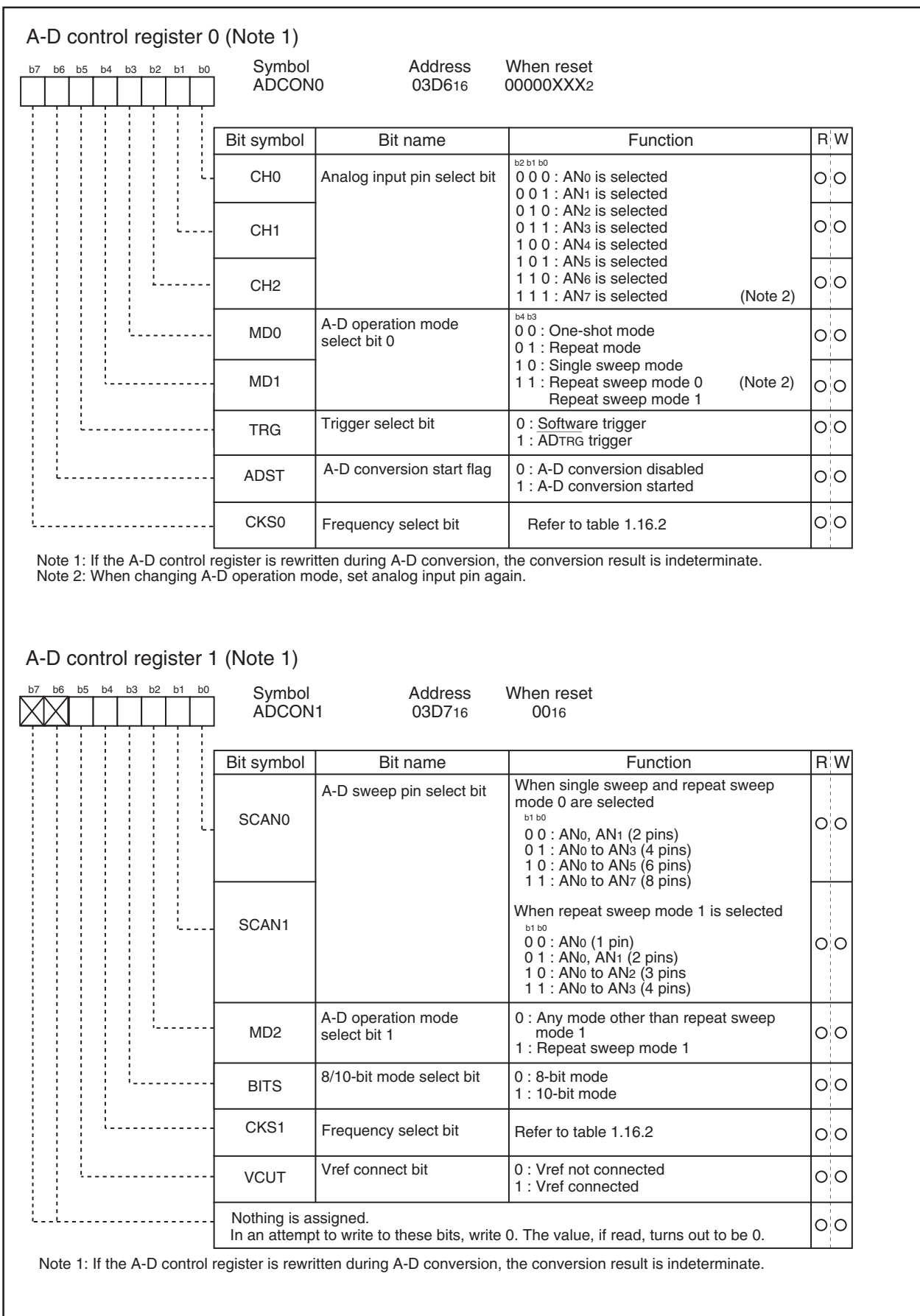

Figure 1.16.2. A-D converter control registers (1)

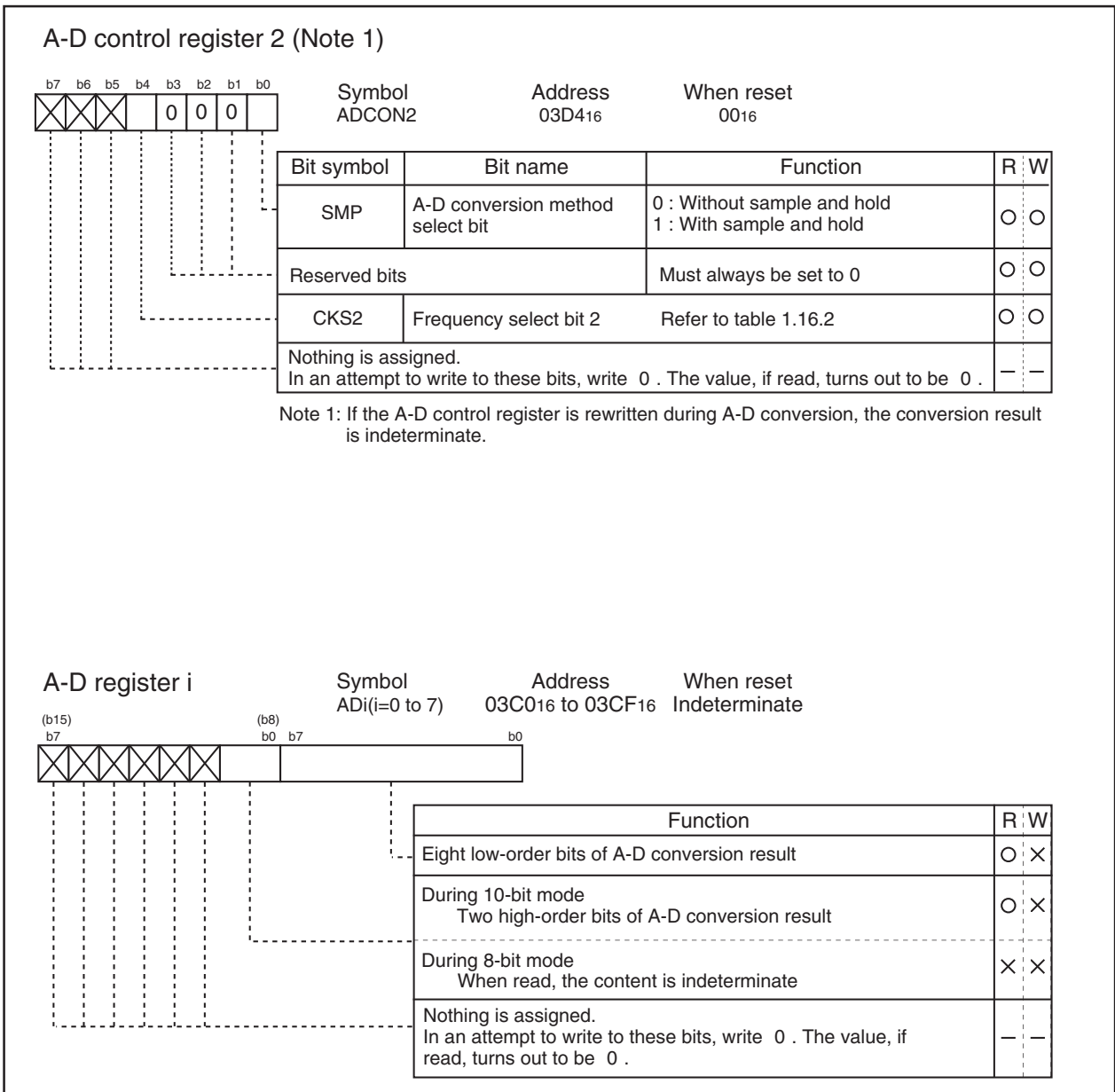

Figure 1.16.3. A-D converter control registers (2)

Table 1.16.2. Operation clock ϕ_{AD}

CKS0	CKS1	CKS2	ϕ_{AD}
0	0	0	$f_{AD}/4$
0	0	1	$f_{AD}/12$
0	1	0	f_{AD}
0	1	1	$f_{AD}/3$
1	0	0	$f_{AD}/2$
1	0	1	$f_{AD}/6$
1	1	0	f_{AD}
1	1	1	$f_{AD}/3$

Note: Divide the f_{AD} if $f(X_{IN})$ exceeds 10MHz, and make ϕ_{AD} frequency equal to or less than 10MHz.

(1) One-shot mode

In one-shot mode, the pin selected using the analog input pin select bits, is used for one-shot A-D conversion. Table 1.16.3 shows the specifications of one-shot mode. Figure 1.16.4 shows the settings of the A-D control registers in one-shot mode.

Table 1.16.3. One-shot mode specifications

Item	Specification
Function	The pin selected by the analog input pin select bits is used for one A-D conversion
Start condition	Writing "1" to the A-D conversion start flag
Stop condition	<ul style="list-style-type: none"> End of A-D conversion (A-D conversion start flag changes to "0" - except when external trigger is selected) Writing "0" to the A-D conversion start flag
Interrupt request generation timing	End of A-D conversion
Input pin	Select one from AN ₀ to AN ₇
Reading of A-D result	Read A-D register that corresponds to selected analog input pin

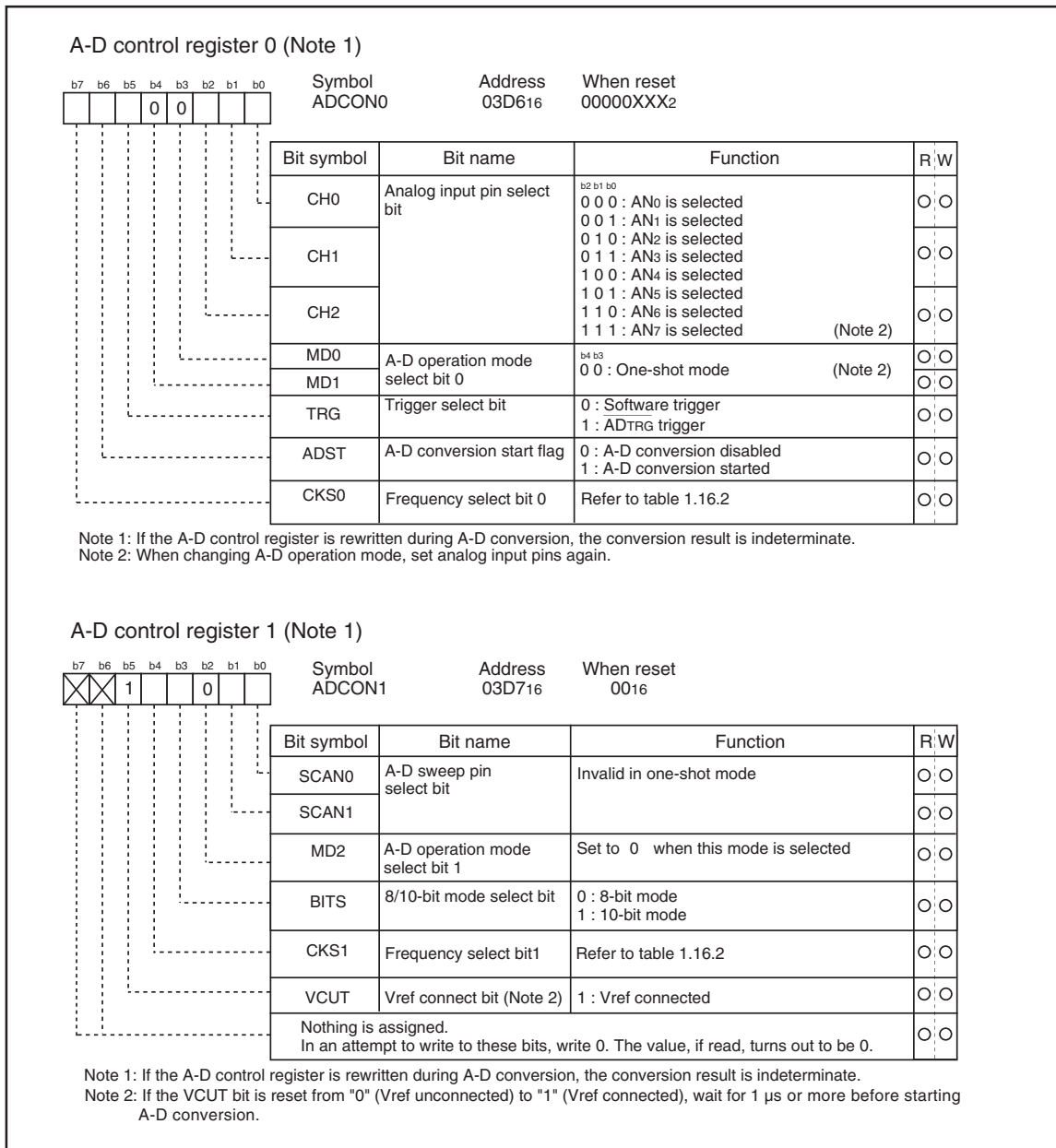

Figure 1.16.4. A-D conversion control registers in one-shot mode

(2) Repeat mode

In repeat mode, the pin selected using the analog input pin select bits, is used for one-shot A-D conversion. Table 1.16.4 shows the specifications of repeat mode. Figure 1.16.5 shows the settings of the A-D control registers in repeat-shot mode.

Table 1.16.4. Repeat mode specifications

Item	Specification
Function	The pin selected by the analog input pin select bits is used for one A-D conversion
Start condition	Writing "1" to the A-D conversion start flag
Stop condition	Writing "0" to the A-D conversion start flag
Interrupt request generation timing	None generated
Input pin	Select one from AN ₀ to AN ₇
Reading of A-D result	Read A-D register that corresponds to selected analog input pin (at any time)

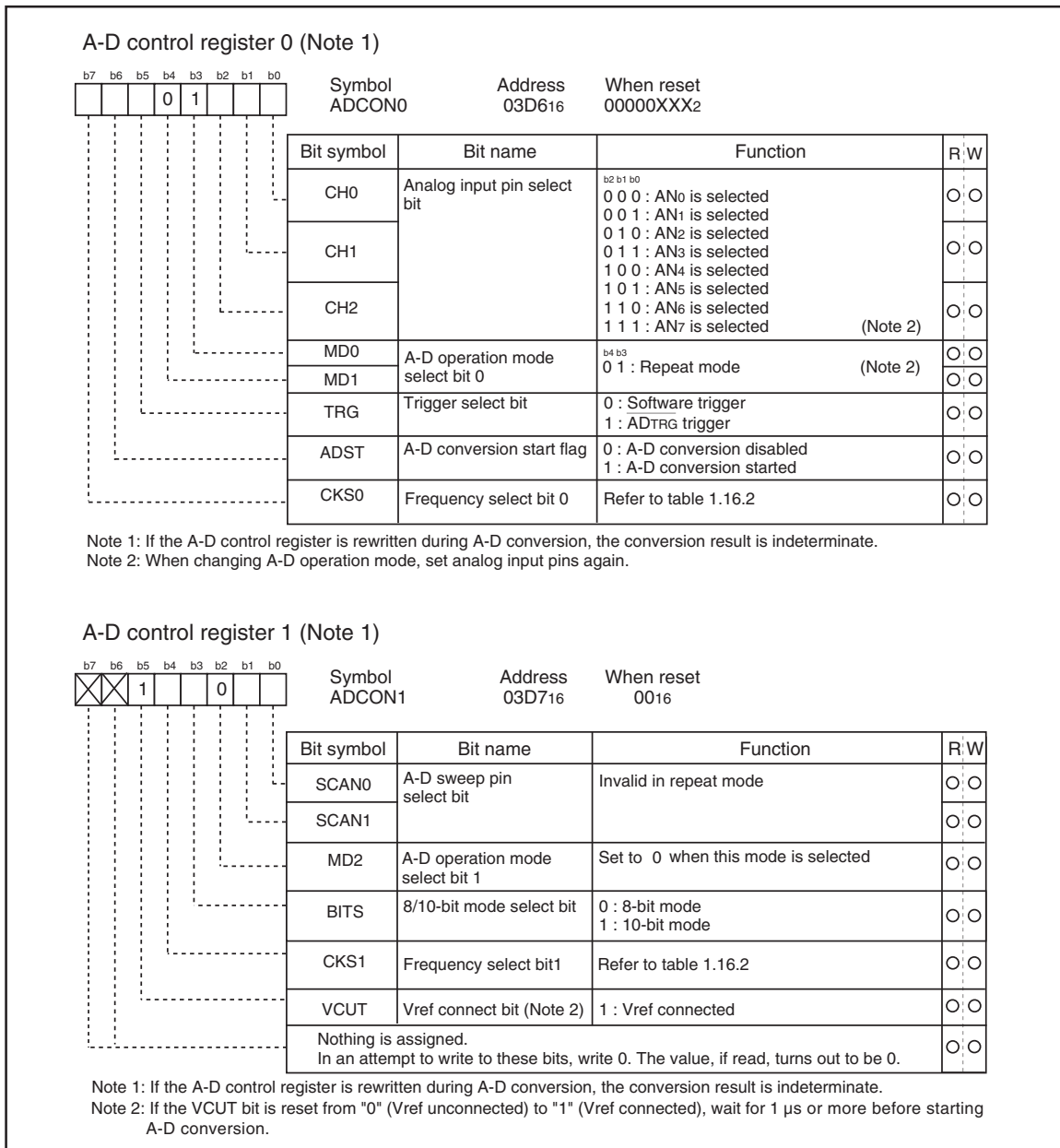

Figure 1.16.5. A-D conversion control registers in repeat mode

(3) Single sweep mode

In single sweep mode, the pins selected using the A-D sweep pin select bits, are used for one-by-one A-D conversion. Table 1.16.5 shows the specifications of single sweep mode. Figure 1.16.6 shows the settings of the A-D control registers in single sweep mode.

Table 1.16.5. Single sweep mode specifications

Item	Specification
Function	The pin selected by the analog input pin select bits is used for one A-D conversion
Start condition	Writing "1" to the A-D conversion start flag
Stop condition	<ul style="list-style-type: none"> End of A-D conversion (A-D conversion start flag changes to "0" - except when external trigger is selected) Writing "0" to the A-D conversion start flag
Interrupt request generation timing	End of A-D conversion
Input pin	AN ₀ - AN ₁ (2 pins), AN ₀ - AN ₃ (4 pins), AN ₀ - AN ₅ (6 pins), or AN ₀ - AN ₇ (8 pins)
Reading of A-D result	Read A-D register that corresponds to selected analog input pin

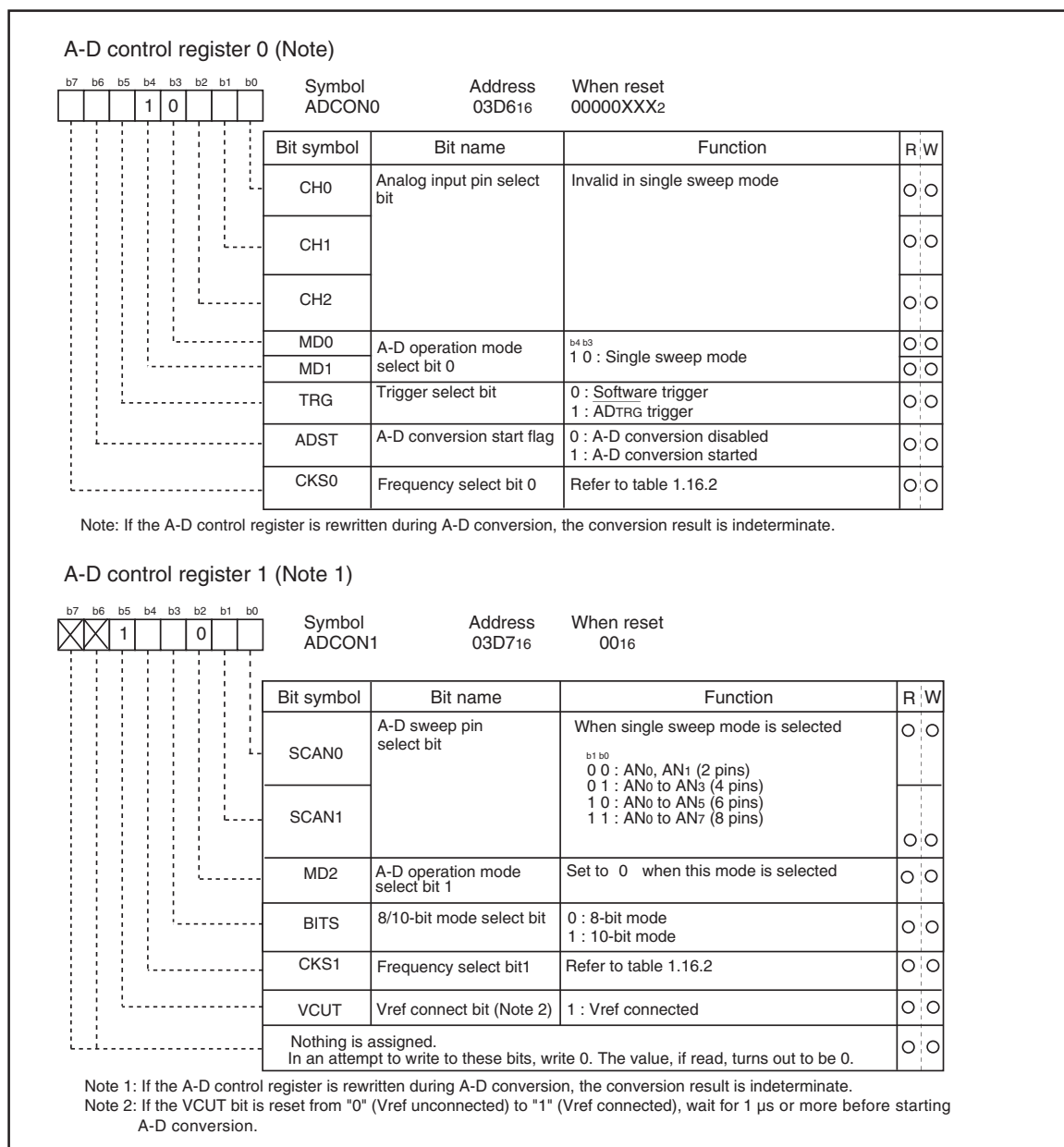

Figure 1.16.6. A-D conversion control registers in single sweep mode

(4) Repeat sweep mode 0

In repeat sweep mode 0, the pins selected using the A-D sweep pin select bits, are used for repeat sweep A-D conversion. Table 1.16.6 shows the specifications of repeat sweep mode 0. Figure 1.16.7 shows the settings of the A-D control registers in repeat sweep mode 0.

Table 1.16.6. Repeat sweep mode 0 specifications

Item	Specification
Function	The pin selected by the analog input pin select bits is used for one A-D conversion
Start condition	Writing "1" to the A-D conversion start flag
Stop condition	Writing "0" to the A-D conversion start flag
Interrupt request generation timing	None generated
Input pin	AN ₀ - AN ₁ (2 pins), AN ₀ - AN ₃ (4 pins), AN ₀ - AN ₅ (6 pins), or AN ₀ - AN ₇ (8 pins)
Reading of A-D result	Read A-D register that corresponds to selected analog input pin (at any time)

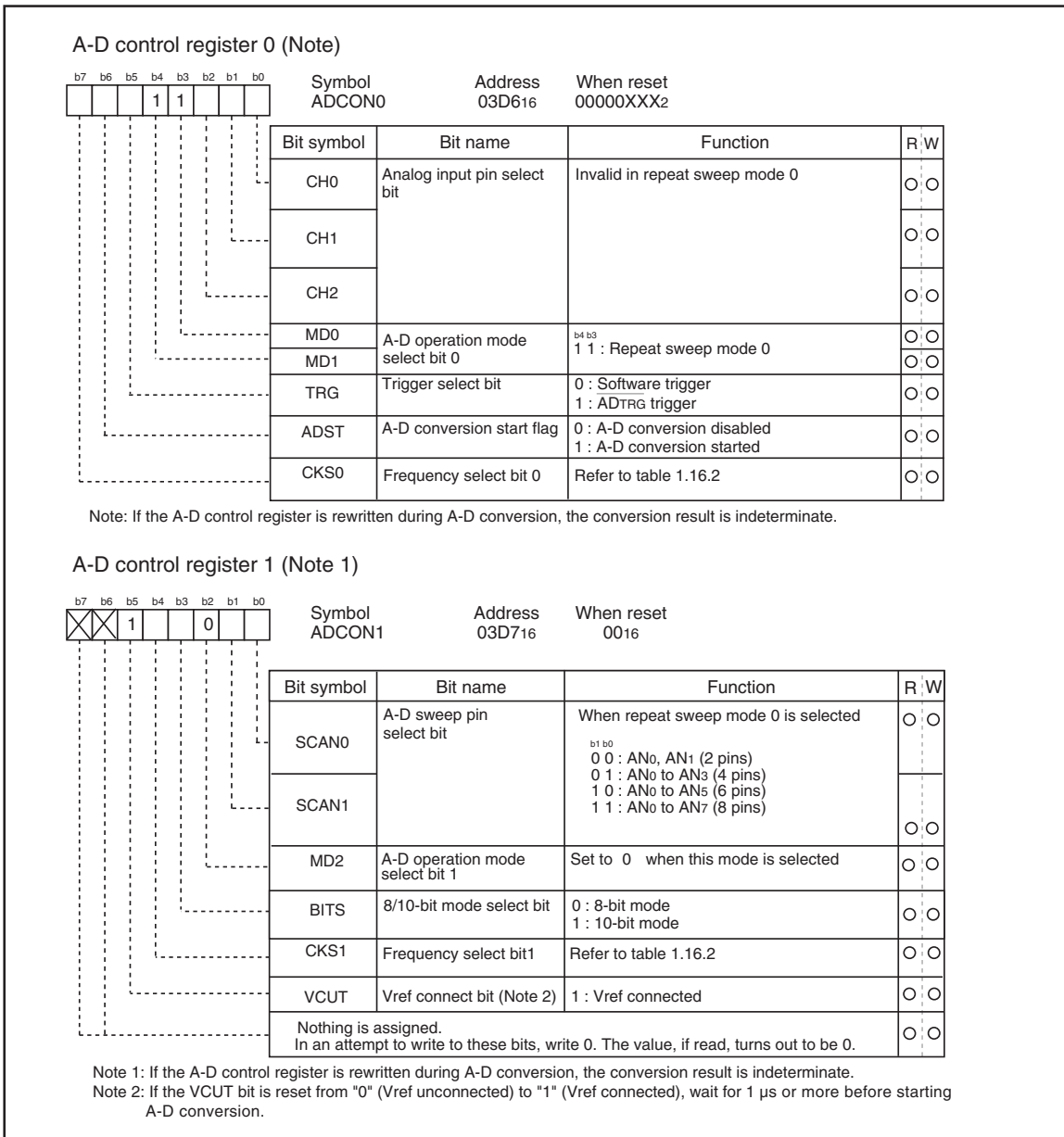

Figure 1.16.7. A-D conversion control registers in repeat sweep mode 0

(5) Repeat sweep mode 1

In repeat sweep mode 1, all pins are used for A-D conversion with emphasis on the pin or pins selected using the A-D sweep pin select bits. Table 1.16.7 shows the specifications of repeat sweep mode 1. Figure 1.16.8 shows the settings of the A-D control registers in repeat sweep mode 1.

Table 1.16.7. Repeat sweep mode 1 specifications

Item	Specification
Function	The pin selected by the analog input pin select bits is used for one A-D conversion
Start condition	Writing "1" to the A-D conversion start flag
Stop condition	Writing "0" to the A-D conversion start flag
Interrupt request generation timing	None generated
Input pin	With emphasis on these pins: AN ₀ , AN ₀ - AN ₁ (2 pins), AN ₀ - AN ₂ (3 pins), AN ₀ - AN ₃ (4 pins)
Reading of A-D result	Read A-D register that corresponds to selected analog input pin (at any time)

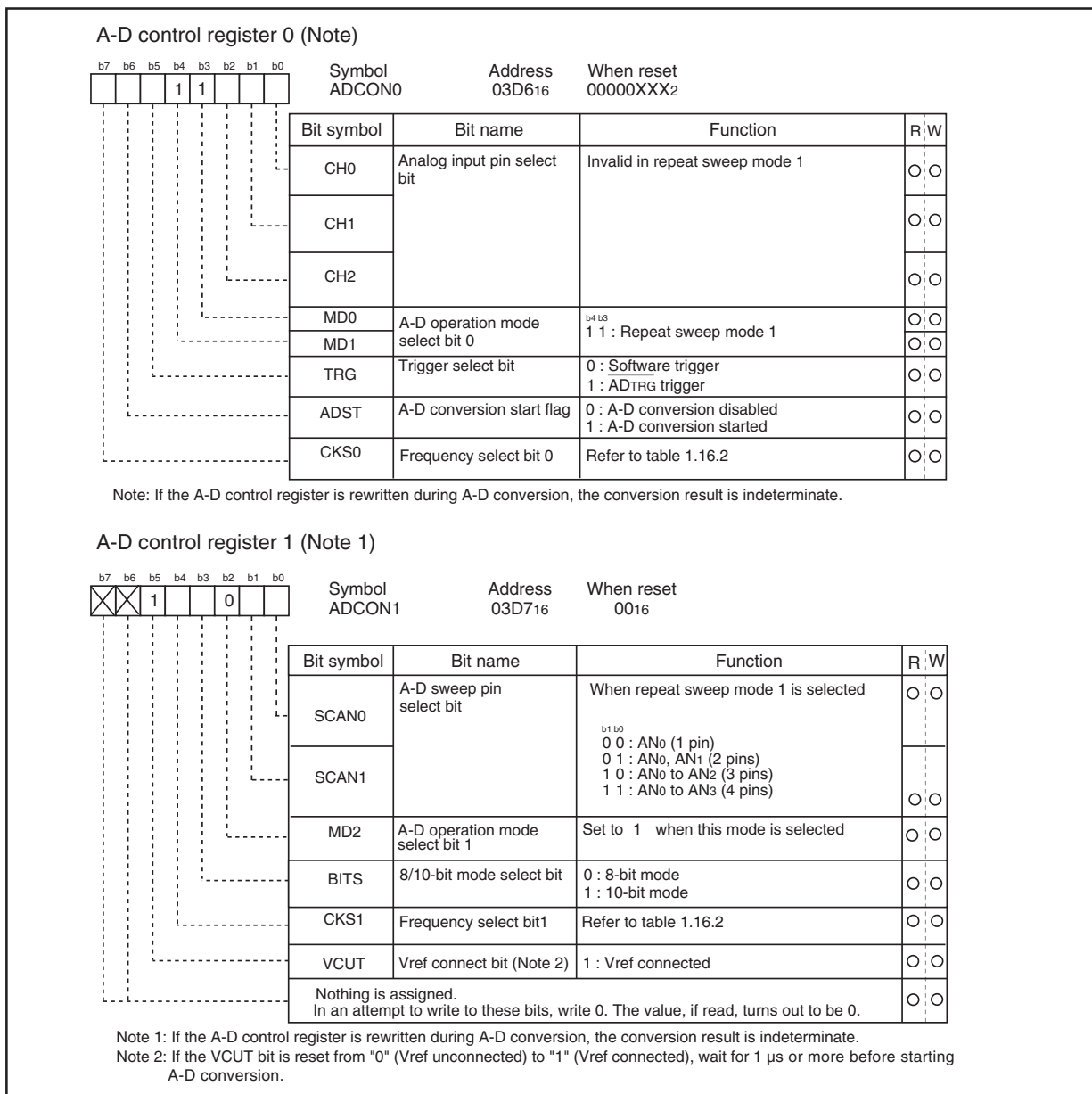

Figure 1.16.8. A-D conversion control registers in repeat sweep mode 1

(a) Sample and Hold

Sample and hold is selected by setting bit 0 of the A-D control register 2 (address 03D4₁₆) to "1". When sample and hold is selected, the rate of conversion of each pin increases. As a result, a 28 ϕ_{AD} cycle is achieved in 8-bit resolution and 33 ϕ_{AD} in 10-bit resolution. Sample and hold can be selected in all modes. However, in all modes, be sure to specify whether to use sample and hold before starting A-D conversion.

(b) Caution of using A-D converter

- (1) Set the port direction bits corresponding to the following pins to input: those P10 pins to be used for analog input, plus external trigger input pin (P15).
- (2) In using a key-input interrupt, none of 4 pins (AN4 through AN7) can be used as an A-D conversion port (if the A-D input voltage goes to "L" level, a key-input interrupt occurs).
- (3) Insert the capacitor between AVCC and AVSS, between VREF and AVSS, and between the analog input pin (ANi) and AVSS, to prevent a malfunction or program runaway, and to reduce conversion error, due to noise. Figure 1.16.9 is an example connection of each pin.

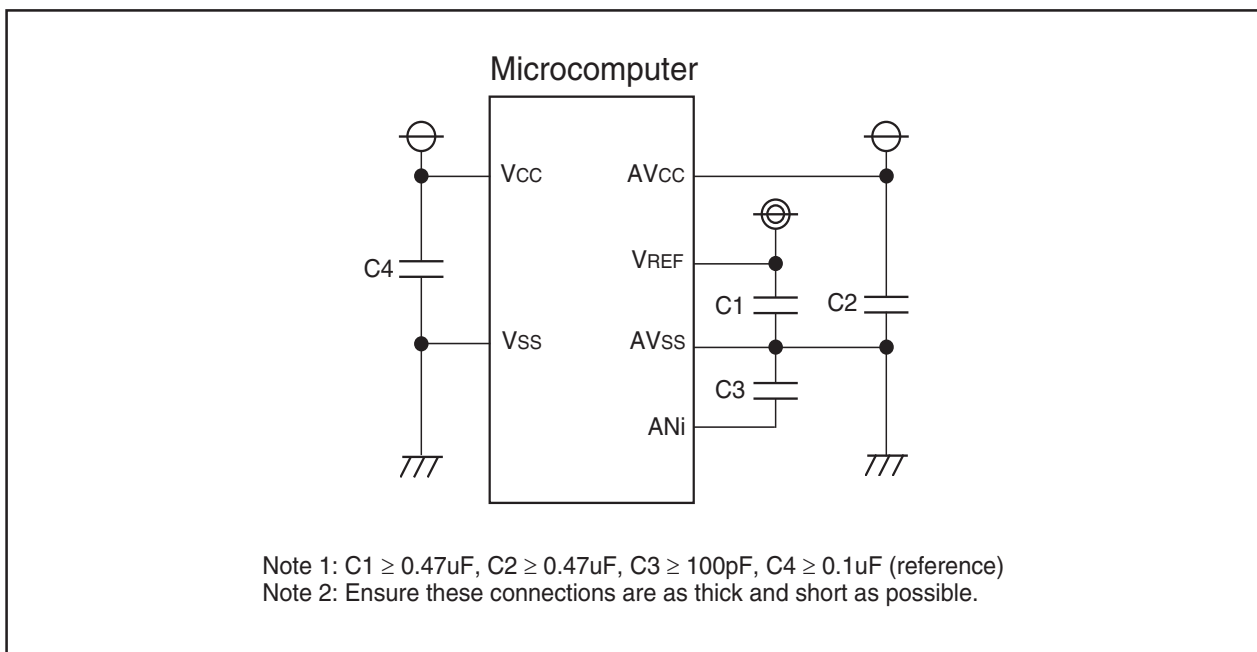

Figure 1.16.9. Example connection of VCC, VSS, AVCC, AVSS, VREF and ANi

Programmable I/O Ports

There are 38 programmable I/O ports: P15 - P17, P6, P7, P8 (except P84), P90 - P93, and P10. Each port can be set independently for input or output using the direction register. A pull-up resistance for each block of 4 ports can be set.

Figures 1.17.1 to 1.17.3 show the programmable I/O ports. Figure 1.17.4 shows the I/O pins.

Each pin functions as a programmable I/O port and as the I/O for the built-in peripheral devices.

To use the pins as the inputs for the built-in peripheral devices, set the direction register of each pin to input mode. When the pins are used as the outputs for the built-in peripheral devices, they function as outputs regardless of the contents of the direction registers. See the descriptions of the respective functions for how to set up the built-in peripheral devices.

(1) Direction registers

Figure 1.17.5 shows the port direction registers.

These registers are used to choose the direction of the programmable I/O ports. Each bit in these registers corresponds one for one to each I/O pin.

Note: The Port 9 direction register incorporates a write protection function. Before writing to the port 9 direction register the write protection must be disabled by setting PRC2 of the Protect register (bit 2 at 000A16) to "1". Note that PRC2 is automatically reset to "0" after the next write to an SFR address.

(2) Port registers

Figure 1.17.6 shows the port registers.

These registers are used to read and write data for input and output to and from an external device. A port register consists of a port latch to hold output data and a circuit to read the status of a pin. Each bit in the port registers corresponds one for one to each I/O pin.

(3) Pull-up control registers

Figure 1.17.7 shows the pull-up control registers.

The pull-up control register can be set to apply a pull-up resistance to each block of 4 ports. When ports are set to have a pull-up resistance, the pull-up resistance is connected only when the direction register is set to input.

(4) Port control register

Figure 1.17.8 shows the port control register.

Bit 0 of the port control register is used to control the read of port P1 as follows:

0 : When port P1 is set as an input port, the port input level is read.

When port P1 is set as an output port, the contents of the port P1 register are read.

1 : The contents of the port P1 register are always read.

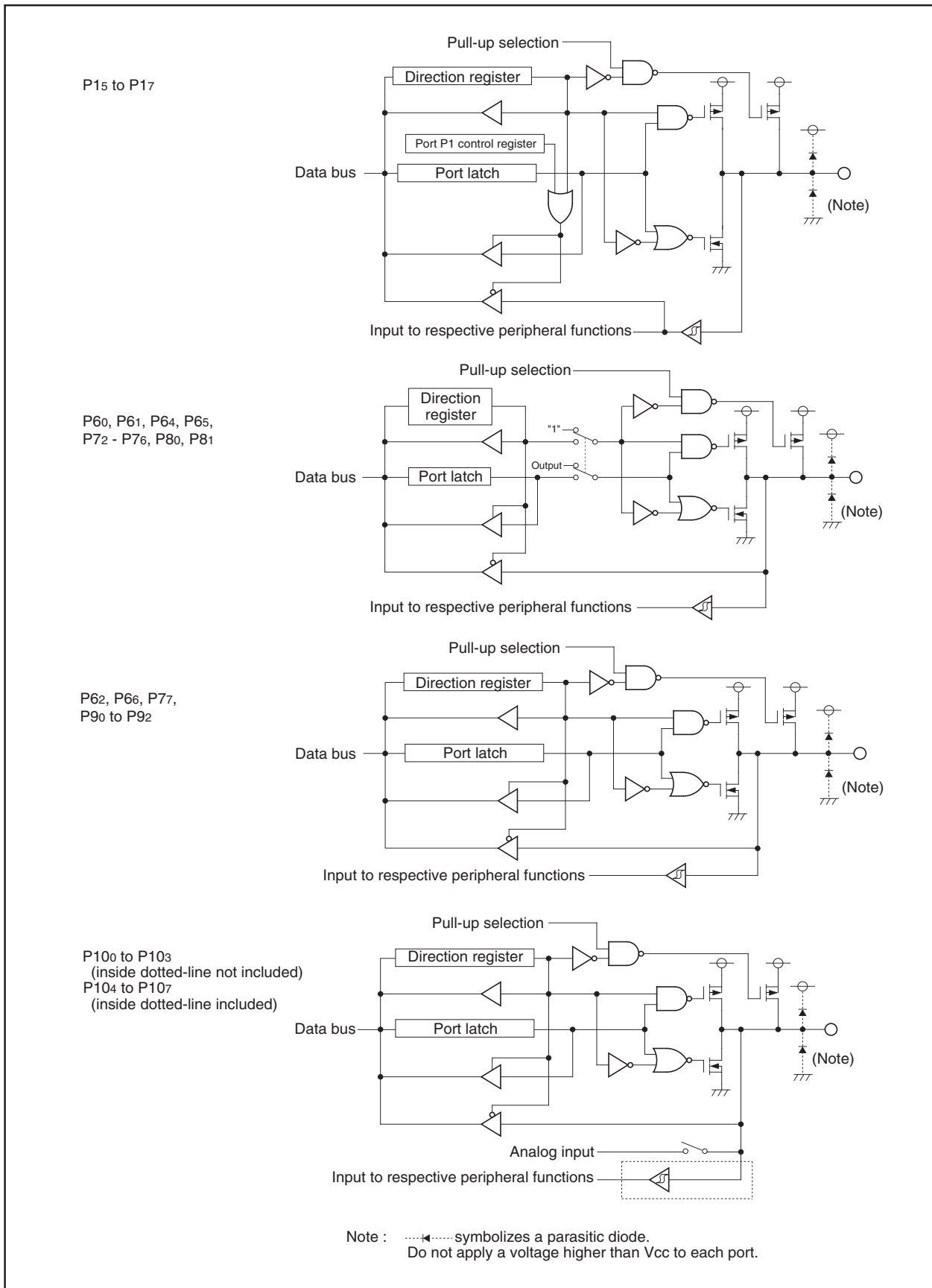

Figure 1.17.1. Programmable I/O ports (1)

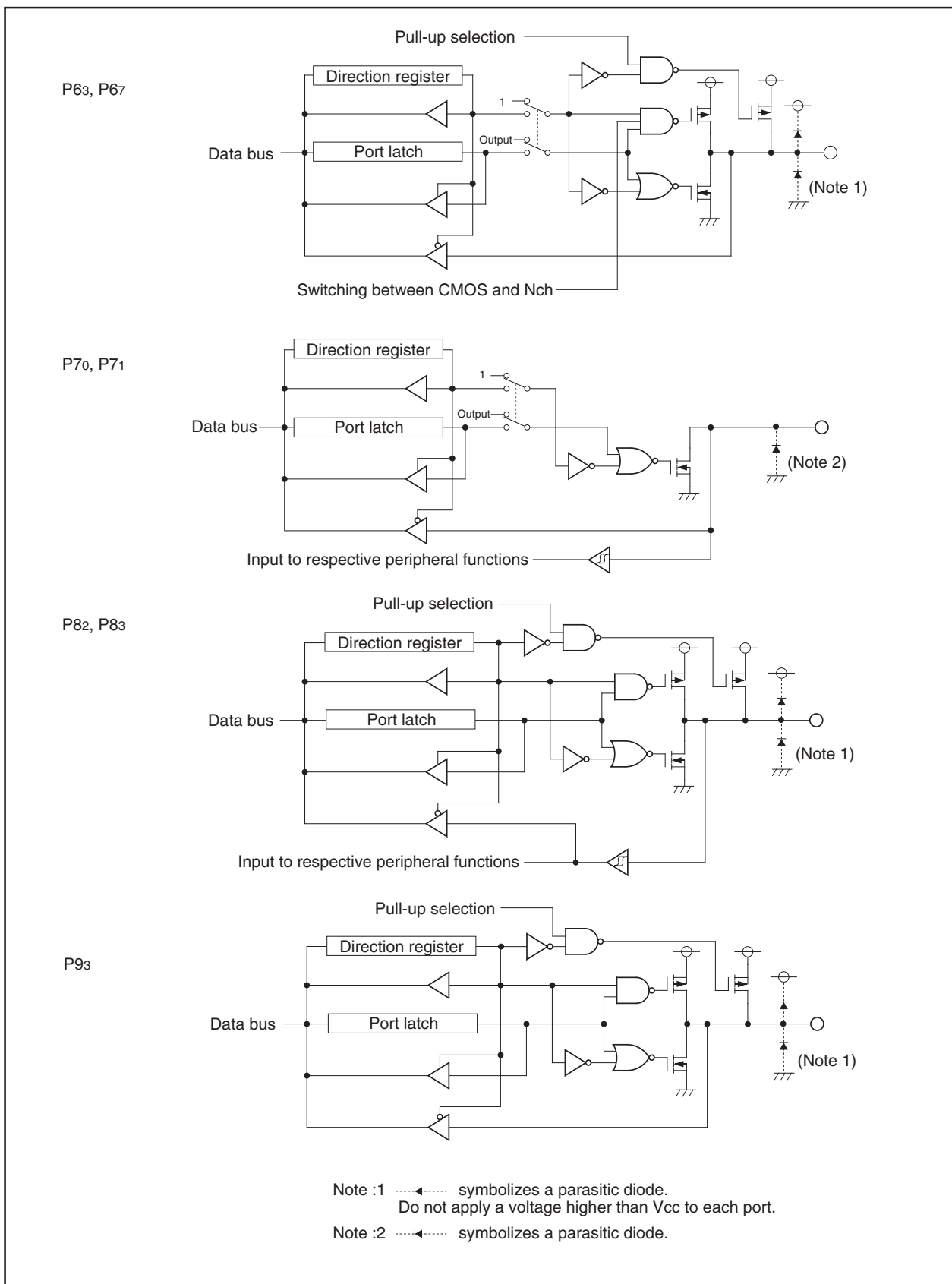

Figure 1.17.2. Programmable I/O ports (2)

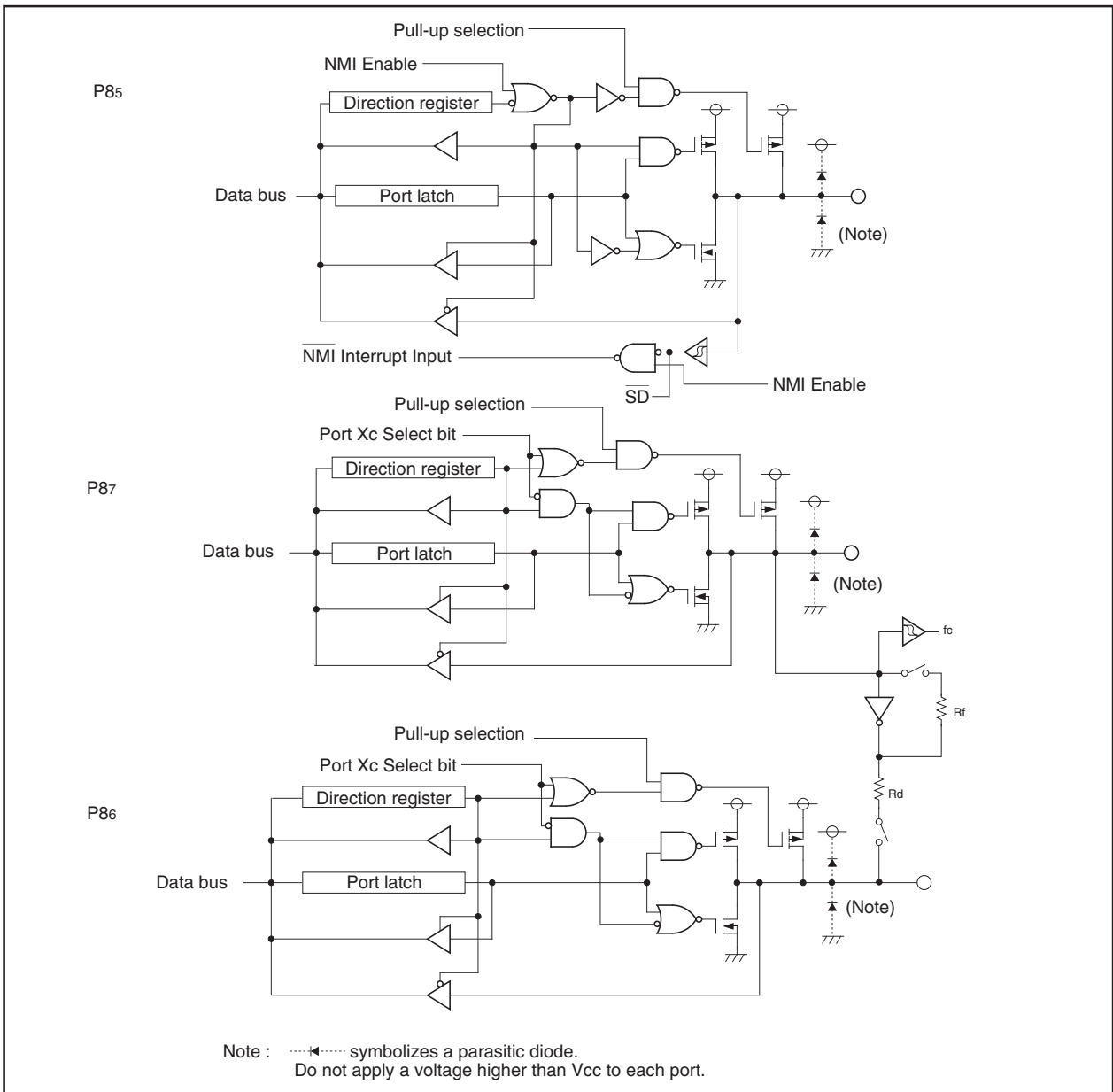

Figure 1.17.3. Programmable I/O ports (3)

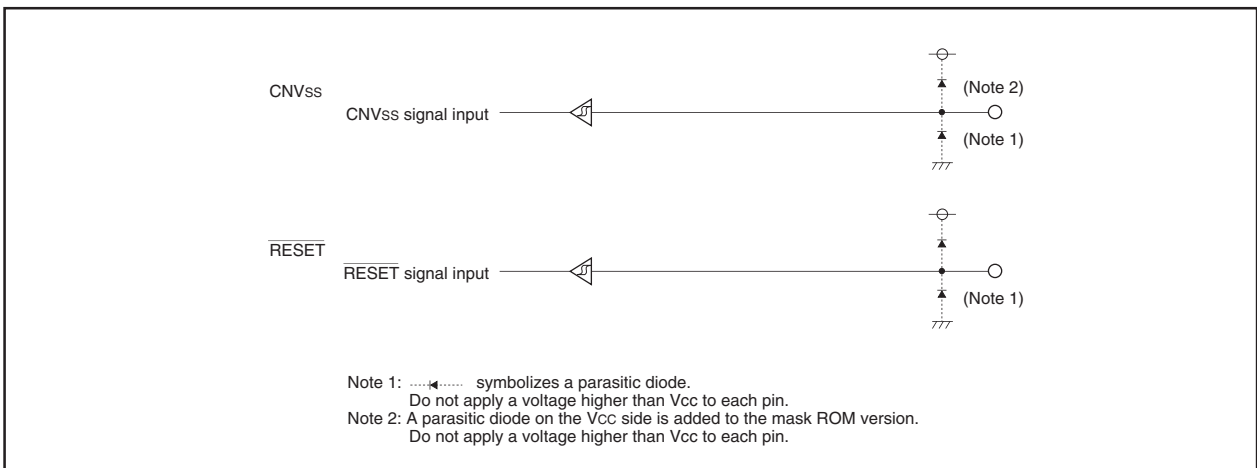

Figure 1.17.4. I/O pins

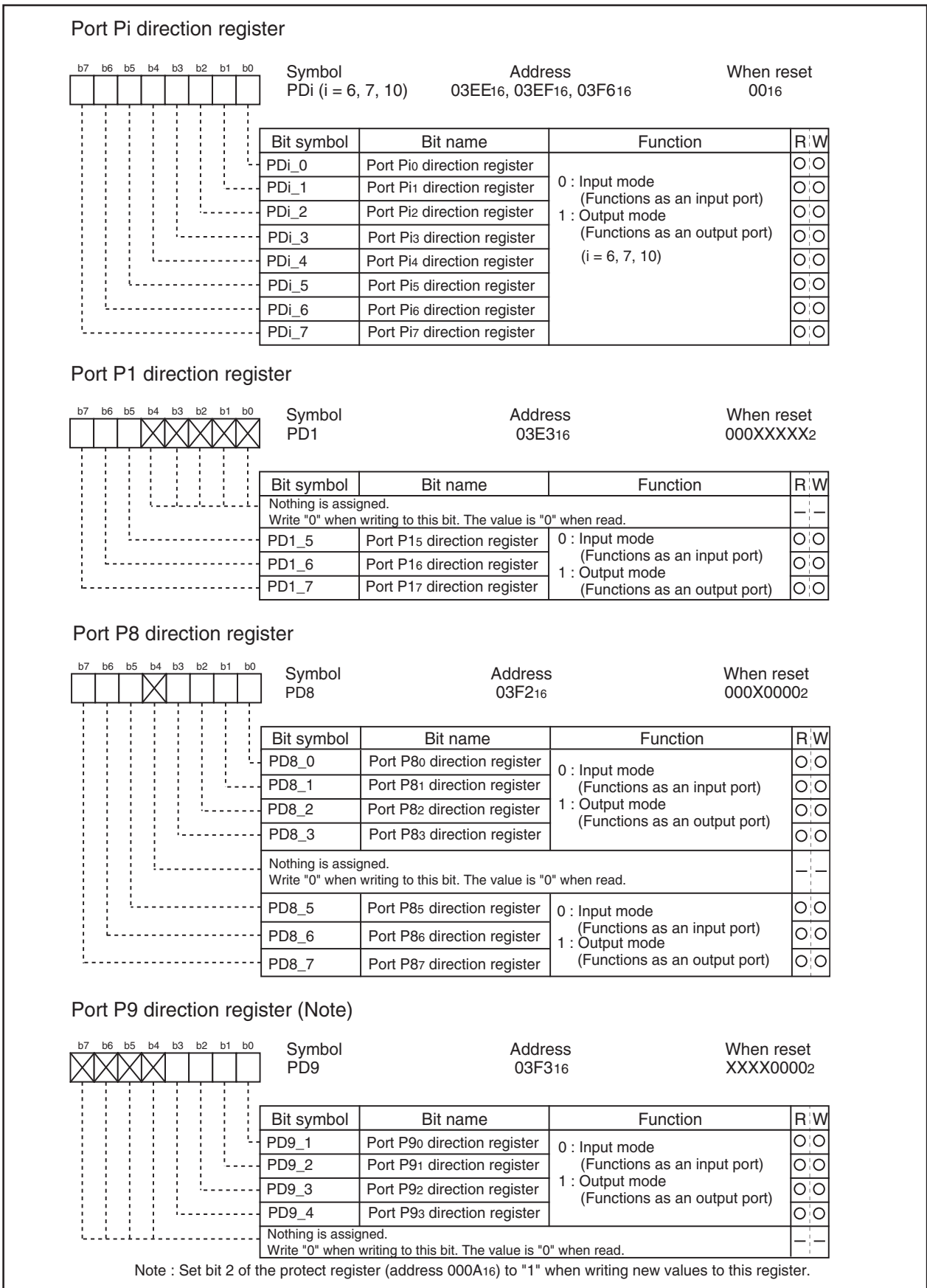

Figure 1.17.5. Direction registers

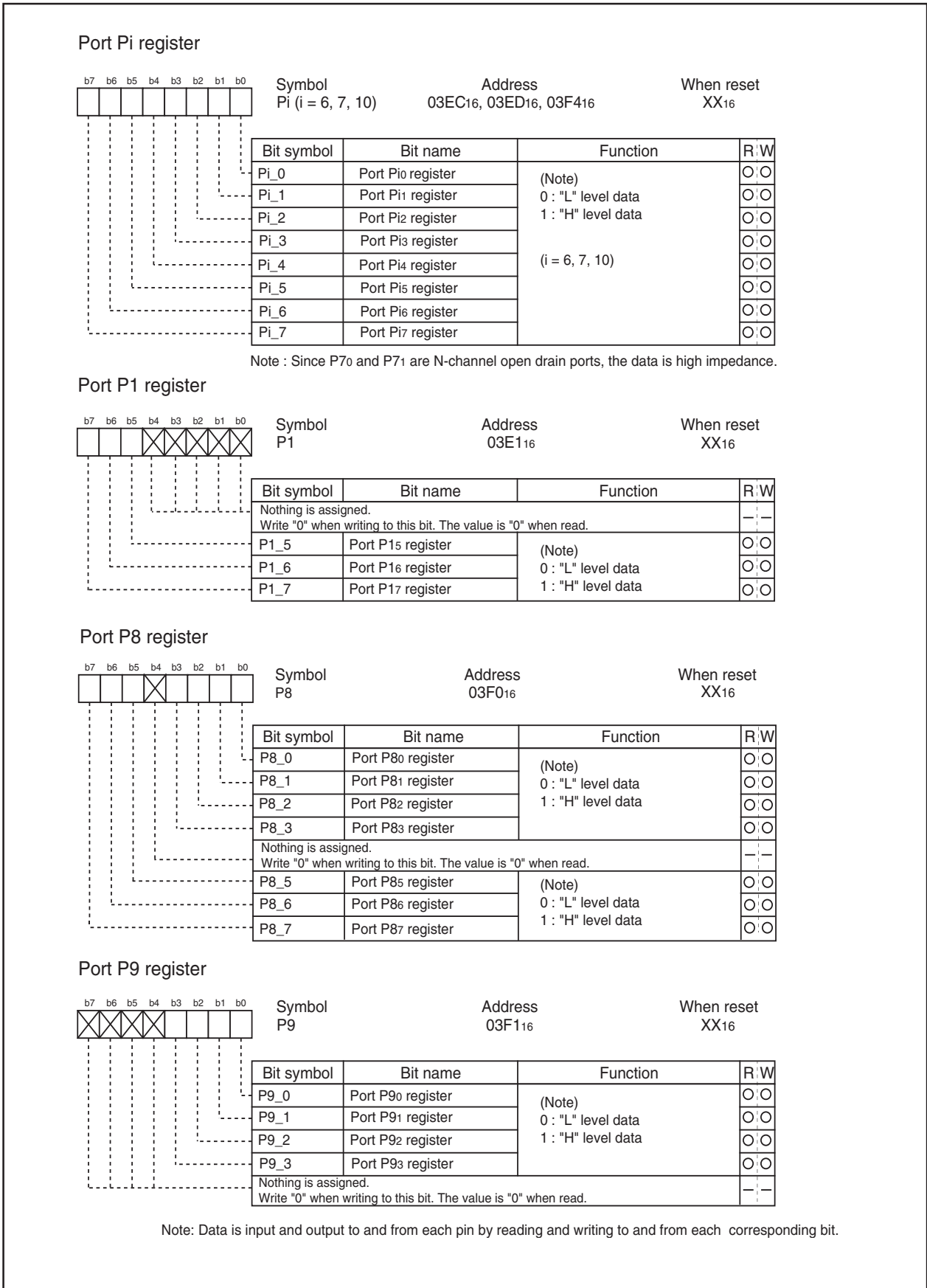

Figure 1.17.6. Port registers

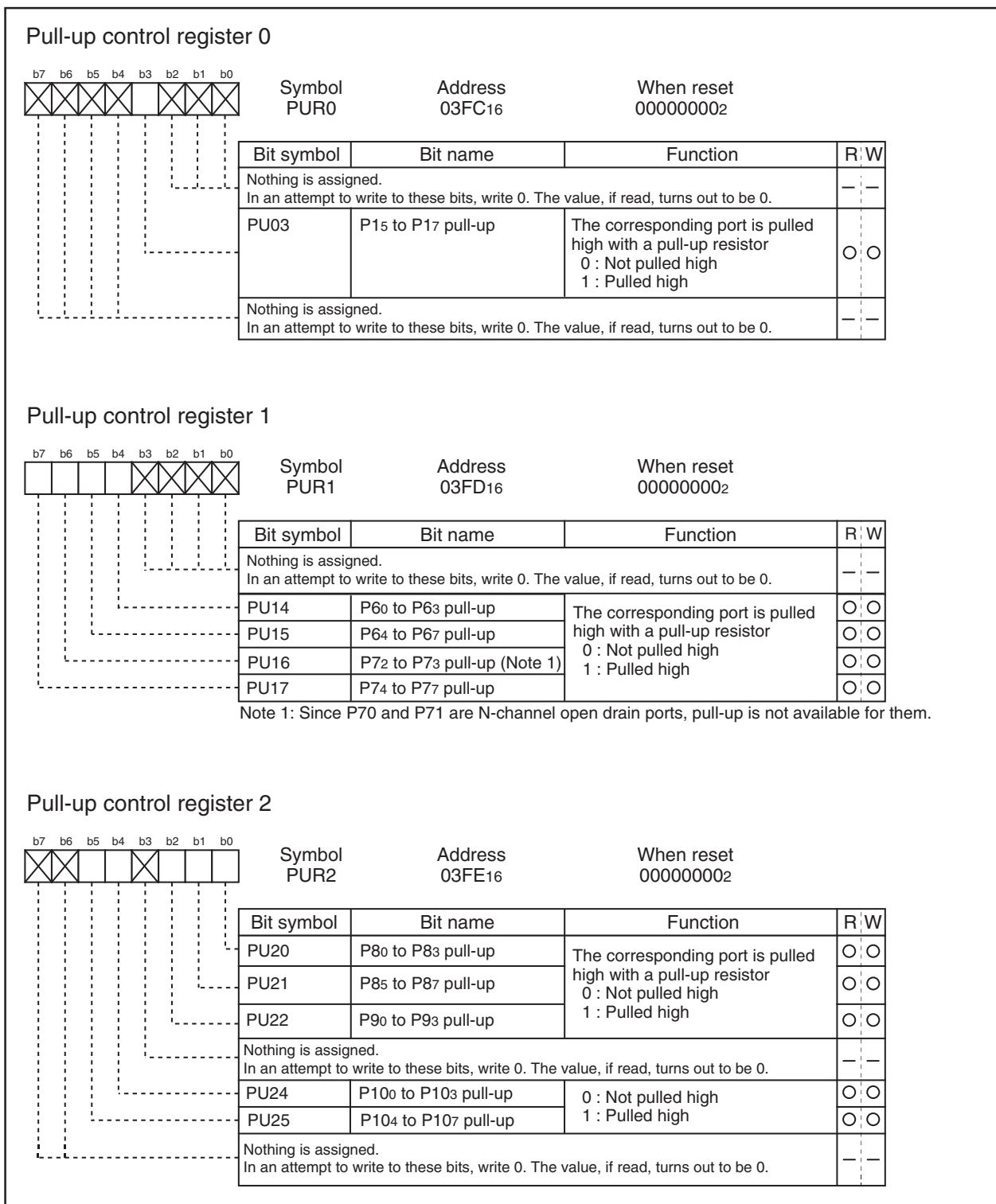

Figure 1.17.7. Pull-up Control registers

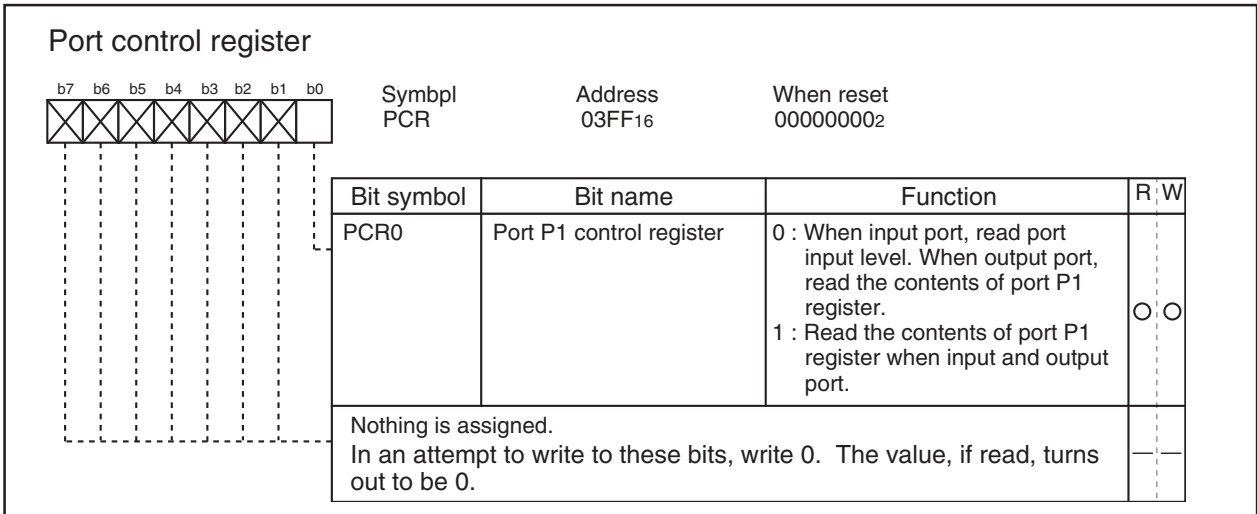

Figure 1.17.8. Port control register

Table 1.17.1. Example connection of unused pins in single-chip mode

Pin name	Connection
Ports P15-P17, P6, P7, P80-P83, P86-P87, P90-P3, P10	After setting to input mode, connect every pin to Vss via a resistor (pull-down); or after setting to output mode, leave these pins open.
P85(NMI/SD)	After setting to input mode, connect to Vcc via a resistor (pull-up).
XOUT (Note 1)	Open
AVcc	Connect to Vcc
AVSS, VREF	Connect to Vss
VDC	Connect via a 0.1uF capacitor to Vss

Note 1: With external clock input to XIN pin.

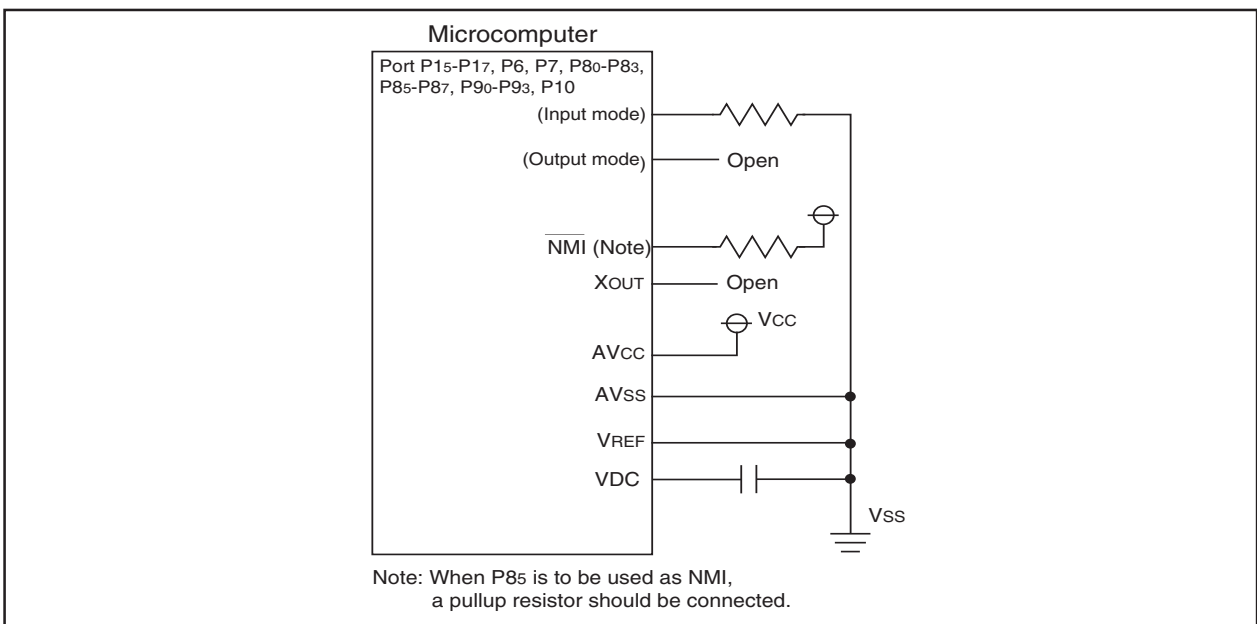

Figure 1.17.9. Example connection of unused pins

Electrical Characteristics

Table 1.18.1. Absolute maximum ratings

Symbol	Parameter		Condition	Rated Value	Unit
V _{CC}	Supply voltage		V _{CC} =AV _{CC}	-0.3 to 6.5	V
AV _{CC}	Analog supply voltage		V _{CC} =AV _{CC}	-0.3 to 6.5	V
V _I	Input voltage	P15 to P17, P60 to P67, P72 to P77, P80 to P83, P85 to P87, P90 to P93, P100 to P107, X _{IN} , V _{REF} , RESET, CNV _{SS}		-0.3 to V _{CC} +0.3	V
		P70, P71		-0.3 to 6.5	V
V _O	Output voltage	P15 to P17, P60 to P67, P72 to P77, P80 to P83, P85 to P87, P90 to P93, P100 to P107, X _{OUT}		-0.3 to V _{CC} +0.3	V
		P70, P71		-0.3 to 6.5	V
P _d	Power dissipation		T _{opr} =25 °C	300	mW
T _{opr}	Operating ambient temperature			-20 to 85 / -40 to 85 (Note)	°C
T _{stg}	Storage temperature			-65 to 150	°C

Note : Specify a product of -40°C to 85°C to use it.

Tables 1.18.2a. & 1.18.2b. Electrical Characteristics for Flash ROM E/W Cycles

Table 1.18.2a. Characteristics (Note 1) for 100 E/W cycle products (D3, D5, U3, U5)

Symbol	Parameter	Standard value			Unit
		Min.	Typ. (Note 2)	Max.	
–	Erase/Write cycle (Note 3)	100 (Note 4)			cycle
–	Word write time		75	600	μs
–	Block erase time	2Kbyte block	0.2	9	s
		8Kbyte block	0.4	9	s
		16Kbyte block	0.7	9	s
		32Kbyte block	1.2	9	s
td(SR-ES)	Time delay from Suspend Request until Erase Suspend			20	ms
–	Data retention time (Note 5)	10			year

Table 1.18.2b. Characteristics (Note 6) for 10000 E/W cycle products (D7, D9, U7, U9) [Block A and Block B (Note 7)]

Symbol	Parameter	Standard value			Unit
		Min.	Typ. (Note 2)	Max.	
–	Erase/Write cycle (Notes 3, 8, 9)	10000 (Notes 4, 10)			cycle
–	Word write time		100		μs
–	Block erase time (2Kbyte block)		0.3		s
td(SR-ES)	Time delay from Suspend Request until Erase Suspend			20	ms

Note 1: When not otherwise specified, V_{CC} = 2.7-5.5V; T_{opr} = 0-60°C.

Note 2: V_{CC}=5.0V; T_{opr} = 25°C.

Note 3: Definition of E/W cycle: Each block may be written to a variable number of times - up to a maximum of the total number of distinct word addresses - for every block erase. Performing multiple writes to the same address before an erase operation is prohibited.

Note 4: Maximum number of E/W cycles for which operation is guaranteed.

Note 5: T_{opr} = -40-85°C (D3, D7, U3, U7) / -20-85°C (D5, D9, U5, U9).

Note 6: When not otherwise specified, V_{CC} = 2.7-5.5V; T_{opr} = -20-85°C (D9, U9) / -40-85°C (D7, U7).

Note 7: Table 1.18.2b applies for Block A or B E/W cycles > 1000. Otherwise, use Table 1.18.2a.

Note 8: To reduce the number of E/W cycles, a block erase should ideally be performed after writing as many different word addresses (only one time each) as possible. It is important to track the total number of block erases.

Note 9: Should erase error occur during block erase, attempt to execute clear status register command, then block erase command at least three times until erase error disappears.

Note 10: When Block A or B E/W cycles exceed 100 (D7, D9, U7, U9), select one wait state per block access. When FMR17 is set to "1", one wait state is inserted per access to Block A or B - regardless of the value of PM17. Wait state insertion during access to all other blocks, as well as to internal RAM, is controlled by PM17 - regardless of the setting of FMR17.

Note 11: Customers desiring E/W failure rate information should contact their Renesas technical support representative.

Table 1.18.3. Recommended operating conditions (referenced to $V_{CC} = 2.7V$ to $5.5V$ at $T_{op} = -20^{\circ}C$ to $85^{\circ}C$ / $-40^{\circ}C$ to $85^{\circ}C$ (Note 3) unless otherwise specified)

Symbol	Parameter		Standard			Unit
			Min.	Typ.	Max.	
V_{CC}	Supply voltage(V_{CC})		2.7		5.5	V
AV_{CC}	Analog supply voltage			V_{CC}		V
V_{SS}	Supply voltage			0		V
AV_{SS}	Analog supply voltage			0		V
V_{IH}	HIGH input voltage	P15 to P17, P60 to P67, P72 to P77, P80 to P83, P85 to P87, P90 to P93, P100 to P107, XIN, RESET, CNVss	0.8 V_{CC}		V_{CC}	V
		P70, P71	0.8 V_{CC}		6.5	V
V_{IL}	LOW input voltage	P15 to P17, P60 to P67, P70 to P77, P80 to P83, P85 to P87, P90 to P93, P100 to P107, XIN, RESET, CNVss	0		0.2 V_{CC}	V
I_{OH} (peak)	HIGH peak output current	P15 to P17, P60 to P67, P72 to P77, P80 to P83, P85 to P87, P90 to P93, P100 to P107			-10.0	mA
I_{OH} (avg)	HIGH average output current	P15 to P17, P60 to P67, P72 to P77, P80 to P83, P85 to P87, P90 to P93, P100 to P107			-5.0	mA
I_{OL} (peak)	LOW peak output current	P15 to P17, P60 to P67, P70 to P77, P80 to P83, P85 to P87, P90 to P93, P100 to P107			10.0	mA
I_{OL} (avg)	LOW average output current	P15 to P17, P60 to P67, P70 to P77, P80 to P83, P85 to P87, P90 to P93, P100 to P107			5.0	mA
f (XIN)	Main clock input oscillation frequency (Note4)	No wait	$V_{CC}=3.0V$ to $5.5V$	0	20	MHz
			$V_{CC}=2.7V$ to $3.0V$	0	$33.33 \times V_{CC} - 80$	MHz
f (XCIN)	Subclock oscillation frequency			32.768	50	kHz
f (Ring)	Ring oscillation frequency			1		MHz
f (BCLK)	CPU operation clock		0		20	MHz

Note 1: The mean output current is the mean value within 100ms.

Note 2: The total I_{OL} (peak) output current for all ports must be 80mA max. The total I_{OH} (peak) output current for all ports must be -80mA max.

Note 3: Specify a product of $-40^{\circ}C$ to $85^{\circ}C$ to use it.

Note 4: Relationship between main clock oscillation frequency and supply voltage.

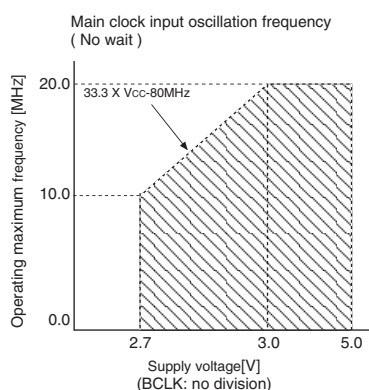

Table 1.18.4. A-D conversion characteristics (Notes 1–3)

Symbol	Parameter		Measuring condition	Standard			Unit
				Min.	Typ.	Max.	
–	Resolution		$V_{REF} = V_{CC}$			10	Bits
INL	Integral non-linearity error	10 bit	$V_{REF} = V_{CC} = 5V$	AN0 to AN7 input		± 3	LSB
			$V_{REF} = V_{CC} = 3.3V$	AN0 to AN7 input		± 5	LSB
		8 bit	$V_{REF} = V_{CC} = 3.3V$				± 2
–	Absolute accuracy	10 bit	$V_{REF} = V_{CC} = 5V$	AN0 to AN7 input		± 3	LSB
			$V_{REF} = V_{CC} = 3.3V$	AN0 to AN7 input		± 5	LSB
		8 bit	$V_{REF} = V_{CC} = 3.3V$				± 2
DNL	Differential non-linearity error					± 1	LSB
–	Offset error					± 3	LSB
–	Gain error					± 3	LSB
RLADDER	Ladder resistance		$V_{REF} = V_{CC}$	10		40	k Ω
t _{CONV}	Conversion time(10bit), Sample & hold function available		$V_{REF} = V_{CC} = 5V, \phi_{AD} = 10MHz$	3.3			μs
t _{CONV}	Conversion time(8bit), Sample & hold function available		$V_{REF} = V_{CC} = 5V, \phi_{AD} = 10MHz$	2.8			μs
t _{SAMP}	Sampling time			0.3			μs
V _{REF}	Reference voltage			2.0		V _{CC}	V
V _{IA}	Analog input voltage			0		V _{REF}	V

Note 1: Referenced to $V_{CC} = AV_{CC} = V_{REF} = 3.3$ to $5.5V$, $V_{SS} = AV_{SS} = 0V$ at $T_{opr} = -20$ to $85^\circ C$ / -40 to $85^\circ C$ unless otherwise specified. Specify a product of -40 to $85^\circ C$ to use it.

Note 2: AD operation clock frequency (ϕ_{AD} frequency) must be 10 MHz or less. And divide the f_{AD} if V_{CC} is less than 4.2V, and make ϕ_{AD} frequency equal to or lower than $f_{AD}/2$.

Note 3: When not using sample & hold function, ϕ_{AD} frequency must be ≥ 250 kHz, but less than the upper limit set by Note 2. When using sample & hold function, ϕ_{AD} frequency must be $\geq 1MHz$, but less than the upper limit set by Note 2.

Table 1.18.5. Flash memory version electrical characteristics

(referenced to $V_{CC} = 5.0V$, at $T_{opr} = 25^\circ C$, unless otherwise specified)

Parameter	Min.	Standard		Max.	Unit	
		Typ.				
		~1K E/W cycles	~10K E/W cycles			
Word program time	–	75	100	–	μs	
Block erase time:	2Kbyte block	–	0.2	0.3	–	s
	8Kbyte block	–	0.4	–	–	
	16Kbyte block	–	0.7	–	–	
	32Kbyte block	–	1.2	–	–	

Table 1.18.6. Low Voltage Detection Circuit Electrical Characteristics (Note 1)

Symbol	Parameter	Measuring condition	Standard			Unit
			Min.	Typ.	Max.	
Vdet4	Power supply down detection voltage (Note 1)	V _{CC} = 0.8 to 5.5V	3.3	3.8	4.4	V
Vdet3	Reset level detection voltage (Note 1)		2.2	2.8	3.6	V
Vdet3s	Low voltage reset retention voltage (Note 2)		0.8			V
Vdet3r	Low voltage reset release voltage		2.2	2.9	4.0	V

Note 1: VDET4 > VDET3

Note 2: VDET3s is the min voltage at which "hardware reset 2" is maintained. Below this voltage, "hardware reset 1" (using reset pin) must be applied in order to resume operation.

Table 1.18.7. Power Supply Circuit Timing Characteristics

Symbol	Parameter	Measuring condition	Standard			Unit
			Min.	Typ.	Max.	
td(R-S)	STOP release time (Note 2)	V _{CC} = 2.7 to 5.5V			150	μs
td(W-S)	Low power dissipation mode wait mode release time (Note 2)				150	μs
td(M-L)	Time for internal power supply stabilization when main clock oscillation starts				50	μs
td(S-R)	Hardware reset 2 release wait time	V _{CC} = VDET3r to 5.5V		6 (Note 1)	20	ms
td(E-A)	Low voltage detection circuit operation start time (Note 3)	V _{CC} = 2.7 to 5.5V			20	μs

Note 1: When V_{CC} = 5V

Note 2: This is the time between interrupt for (STOP/WAIT) mode release and resumption of CPU clock operation.

Note 3: After enabling low voltage detection, this time is required before proper detection can occur.

Table 1.18.8. Hardware Reset 2 Release Wait Time

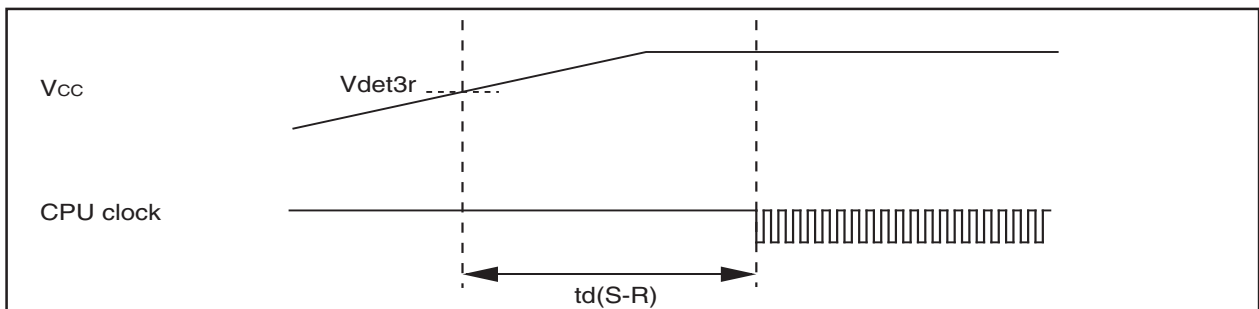
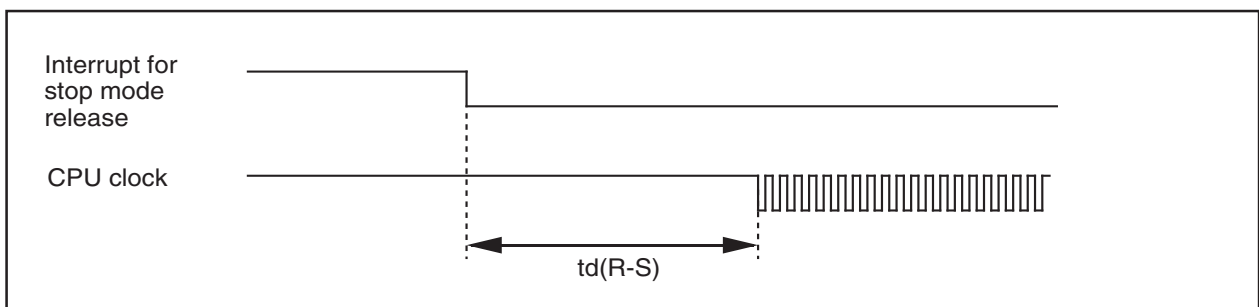

Table 1.18.9. STOP Release Time



V_{CC} = 5VTable 1.18.10. Electrical characteristics (referenced to V_{CC} = 4.2V to 5.5V, V_{SS} = 0Vat T_{opr} = -20°C to 85°C / -40°C to 85°C (Note 2), f(X_{IN}) = 20MHz unless otherwise specified)

Symbol	Parameter		Measuring condition	Standard			Unit
				Min.	Typ.	Max.	
V _{OH}	HIGH output voltage	P15 to P17, P60 to P67, P72 to P77, P80 to P83, P85 to P87, P90 to P93, P100 to P107	I _{OH} =-5mA	3.0		V _{CC}	V
V _{OH}	HIGH output voltage	P15 to P17, P60 to P67, P72 to P77, P80 to P83, P85 to P87, P90 to P93, P100 to P107	I _{OH} =-200μA	4.7		V _{CC}	V
V _{OH}	HIGH output voltage	X _{OUT}	HIGHPOWER	I _{OL} =-1mA	3.0	V _{CC}	V
			LOWPOWER	I _{OH} =-0.5mA	3.0	V _{CC}	
	HIGH output voltage	X _{COUT}	HIGHPOWER	With no load applied		2.5	V
			LOWPOWER	With no load applied		1.6	
V _{OL}	LOW output voltage	P15 to P17, P60 to P67, P70 to P77, P80 to P83, P85 to P87, P90 to P93, P100 to P107	I _{OL} =5mA			2.0	V
V _{OL}	LOW output voltage	P15 to P17, P60 to P67, P70 to P77, P80 to P83, P85 to P87, P90 to P93, P100 to P107	I _{OL} =200μA			0.45	V
V _{OL}	LOW output voltage	X _{OUT}	HIGHPOWER	I _{OL} =1mA		2.0	V
			LOWPOWER	I _{OL} =0.5mA		2.0	
	LOW output voltage	X _{COUT}	HIGHPOWER	With no load applied		0	V
			LOWPOWER	With no load applied		0	
V _{T+} -V _{T-}	Hysteresis	TA0 _{IN} to TA4 _{IN} , TB0 _{IN} to TB2 _{IN} , INT ₀ , INT ₁ , INT ₃ to INT ₅ , NMI, AD _{TRG} , CTS ₀ to CTS ₂ , SCL, SDA, CLK ₀ to CLK ₂ , TA2 _{OUT} to TA4 _{OUT} , K _{I0} to K _{I3} , RxD ₀ to RxD ₂		0.2		1.0	V
V _{T+} -V _{T-}	Hysteresis	RESET		0.2		2.5	V
I _{IH}	HIGH input current	P15 to P17, P60 to P67, P70 to P77, P80 to P83, P85 to P87, P90 to P93, P100 to P107 X _{IN} , RESET, CNV _{SS}	V _I =5V			5.0	μA
I _{IL}	LOW input current	P15 to P17, P60 to P67, P70 to P77, P80 to P83, P85 to P87, P90 to P93, P100 to P107 X _{IN} , RESET, CNV _{SS}	V _I =0V			-5.0	μA
R _{PULLUP}	Pull-up resistance	P15 to P17, P60 to P67, P72 to P77, P80 to P83, P85 to P87, P90 to P93, P100 to P107	V _I =0V	30.0	50.0	170.0	kΩ
R _{XIN}	Feedback resistance	X _{IN}				1.5	MΩ
R _{X_{CIN}}	Feedback resistance	X _{CIN}				15	MΩ
V _{RAM}	RAM retention voltage		When clock is stopped	2.0			V
I _{CC}	Power supply current (V _{CC} = 3.0 to 5.5V)	The output pins are open and other pins are V _{SS}	Flash memory version	f(X _{IN}) = 20MHz Square wave, no division	16	19	mA
			Flash memory version	f(X _{CIN}) = 32kHz Square wave, in RAM	25		μA
			Flash memory version	f(X _{CIN}) = 32kHz Square wave, in Flash	420		μA
			Flash memory version	f(X _{CIN}) = 32kHz When a WAIT instruction is executed. (Note 1) Oscillation capacity High	7.5		μA
f(X _{CIN}) = 32kHz When a WAIT instruction is executed. (Note 1) Oscillation capacity Low	2.0			μA			
			T _{opr} = 25°C when clock is stopped	0.8	3.0	μA	
IDET4	VDET4 detection dissipation current (Note 3)				0.7	4	μA
IDET3	Reset level detection dissipation current (Note 3)				1.2	8	μA

Note 1: With one timer operated using fc32.

Note 2: Specify a product of -40°C to 85°C to use it.

Note 3: IDET is dissipation current when the following bit is set to "1" (detection circuit enabled)

V_{CC} = 5V**Timing requirements**(referenced to V_{CC} = 5V, V_{SS} = 0V, at T_{opr} = - 20 to 85°C / - 40 to 85°C (*) unless otherwise specified)

* : Specify a product of -40 to 85°C to use it.

Table 1.18.11. External Clock Input (X_{IN} input)

Symbol	Parameter	Standard		Unit
		Min.	Max.	
t _c	External clock input cycle time	50		ns
t _{w(H)}	External clock input HIGH pulse width	22		ns
t _{w(L)}	External clock input LOW pulse width	22		ns
t _r	External clock rise time		5	ns
t _f	External clock fall time		5	ns

V_{CC} = 5V**Timing requirements**(referenced to V_{CC} = 5V, V_{SS} = 0V, at T_{opr} = – 20 to 85°C / – 40 to 85°C (*) unless otherwise specified)

* : Specify a product of -40 to 85°C to use it.

Table 1.18.12. Timer A input (counter input in event counter mode)

Symbol	Parameter	Standard		Unit
		Min.	Max.	
t _c (TA)	TAiIn input cycle time	100		ns
t _w (TAH)	TAiIn input HIGH pulse width	40		ns
t _w (TAL)	TAiIn input LOW pulse width	40		ns

Table 1.18.13. Timer A input (gating input in timer mode)

Symbol	Parameter	Standard		Unit
		Min.	Max.	
t _c (TA)	TAiIn input cycle time	400		ns
t _w (TAH)	TAiIn input HIGH pulse width	200		ns
t _w (TAL)	TAiIn input LOW pulse width	200		ns

Table 1.18.14. Timer A input (external trigger input in one-shot timer mode)

Symbol	Parameter	Standard		Unit
		Min.	Max.	
t _c (TA)	TAiIn input cycle time	200		ns
t _w (TAH)	TAiIn input HIGH pulse width	100		ns
t _w (TAL)	TAiIn input LOW pulse width	100		ns

Table 1.18.15. Timer A input (external trigger input in pulse width modulation mode)

Symbol	Parameter	Standard		Unit
		Min.	Max.	
t _w (TAH)	TAiIn input HIGH pulse width	100		ns
t _w (TAL)	TAiIn input LOW pulse width	100		ns

Table 1.18.16. Timer A input (up/down input in event counter mode)

Symbol	Parameter	Standard		Unit
		Min.	Max.	
t _c (UP)	TAiOUT input cycle time	2000		ns
t _w (UPH)	TAiOUT input HIGH pulse width	1000		ns
t _w (UPL)	TAiOUT input LOW pulse width	1000		ns
t _{su} (UP-TiN)	TAiOUT input setup time	400		ns
t _h (TiN-UP)	TAiOUT input hold time	400		ns

Table 1.18.17. Timer A input (two-phase pulse input in event counter mode)

Symbol	Parameter	Standard		Unit
		Min.	Max.	
t _c (TA)	TAiIn input cycle time	800		ns
t _{su} (TAiN-TAOUT)	TAiOUT input setup time	200		ns
t _{su} (TAOUT-TAiN)	TAiIn input setup time	200		ns

V_{CC} = 5V**Timing requirements**(referenced to V_{CC} = 5V, V_{SS} = 0V, at T_{opr} = - 20 to 85°C / - 40 to 85°C (*) unless otherwise specified)

* : Specify a product of -40 to 85°C to use it.

Table 1.18.18. Timer B input (counter input in event counter mode)

Symbol	Parameter	Standard		Unit
		Min.	Max.	
t _c (TB)	TBiIn input cycle time (counted on one edge)	100		ns
t _w (TBH)	TBiIn input HIGH pulse width (counted on one edge)	40		ns
t _w (TBL)	TBiIn input LOW pulse width (counted on one edge)	40		ns
t _c (TB)	TBiIn input cycle time (counted on both edges)	200		ns
t _w (TBH)	TBiIn input HIGH pulse width (counted on both edges)	80		ns
t _w (TBL)	TBiIn input LOW pulse width (counted on both edges)	80		ns

Table 1.18.19. Timer B input (pulse period measurement mode)

Symbol	Parameter	Standard		Unit
		Min.	Max.	
t _c (TB)	TBiIn input cycle time	400		ns
t _w (TBH)	TBiIn input HIGH pulse width	200		ns
t _w (TBL)	TBiIn input LOW pulse width	200		ns

Table 1.18.20. Timer B input (pulse width measurement mode)

Symbol	Parameter	Standard		Unit
		Min.	Max.	
t _c (TB)	TBiIn input cycle time	400		ns
t _w (TBH)	TBiIn input HIGH pulse width	200		ns
t _w (TBL)	TBiIn input LOW pulse width	200		ns

Table 1.18.21. A-D trigger input

Symbol	Parameter	Standard		Unit
		Min.	Max.	
t _c (AD)	ADTRG input cycle time (trigger able minimum)	1000		ns
t _w (ADL)	ADTRG input LOW pulse width	125		ns

Table 1.18.22. Serial I/O

Symbol	Parameter	Standard		Unit
		Min.	Max.	
t _c (CK)	CLKi input cycle time	200		ns
t _w (CKH)	CLKi input HIGH pulse width	100		ns
t _w (CKL)	CLKi input LOW pulse width	100		ns
t _d (C-Q)	TxDi output delay time		80	ns
t _h (C-Q)	TxDi hold time	0		ns
t _{su} (D-C)	RxDi input setup time	30		ns
t _h (C-D)	RxDi input hold time	90		ns

Table 1.18.23. External interrupt INTi inputs

Symbol	Parameter	Standard		Unit
		Min.	Max.	
t _w (INH)	INTi input HIGH pulse width	250		ns
t _w (INL)	INTi input LOW pulse width	250		ns

V_{CC} = 3V

Table 1.18.24. Electrical characteristics (referenced to V_{CC} = 2.7 to 3.3V, V_{SS} = 0V at Topr = -20°C to 85°C / -40°C to 85°C (Note 1), f(X_{IN}) = 10MHz with wait unless otherwise specified)

Symbol	Parameter		Measuring condition	Standard			Unit
				Min.	Typ.	Max.	
V _{OH}	HIGH output voltage	P15 to P17, P60 to P67, P72 to P77, P80 to P83, P85 to P87, P90 to P93, P100 to P107	I _{OH} =-1mA	2.5			V
V _{OH}	HIGH output voltage	X _{OUT}	HIGHPOWER	I _{OH} =-0.1mA	2.5		V
			LOWPOWER	I _{OH} =-50μA	2.5		V
	HIGH output voltage	X _{COUT}	HIGHPOWER	With no load applied		2.5	V
			LOWPOWER	With no load applied		1.6	V
V _{OL}	LOW output voltage	P15 to P17, P60 to P67, P70 to P77, P80 to P83, P85 to P87, P90 to P93, P100 to P107	I _{OL} =1mA			0.5	V
V _{OL}	LOW output voltage	X _{OUT}	HIGHPOWER	I _{OL} =0.1mA		0.5	V
			LOWPOWER	I _{OL} =50μA		0.5	V
	LOW output voltage	X _{COUT}	HIGHPOWER	With no load applied		0	V
			LOWPOWER	With no load applied		0	V
V _{T+} -V _{T-}	Hysteresis	TA0 _{IN} to TA4 _{IN} , TB0 _{IN} to TB2 _{IN} , INT0, INT1, INT3 to INT5, NMI, AD _{TRG} , CTS0 to CTS2, SCL, SDA, CLK0 to CLK2, TA2 _{OUT} to TA4 _{OUT} , K10 to K13, RxD0 to RxD2		0.2		0.8	V
V _{T+} -V _{T-}	Hysteresis	RESET		0.2		1.8	V
I _{IH}	HIGH input current	P15 to P17, P60 to P67, P70 to P77, P80 to P83, P85 to P87, P90 to P93, P100 to P107 X _{IN} , RESET, CNV _{SS}	V _I =3V			4.0	μA
I _{IL}	LOW input current	P15 to P17, P60 to P67, P70 to P77, P80 to P83, P85 to P87, P90 to P93, P100 to P107 X _{IN} , RESET, CNV _{SS}	V _I =0V			-4.0	μA
R _{PULLUP}	Pull-up resistance	P15 to P17, P60 to P67, P72 to P77, P80 to P83, P85 to P87, P90 to P93, P100 to P107	V _I =0V	66	160	500	kΩ
R _{I_{XIN}}	Feedback resistance	X _{IN}			3.0		MΩ
R _{I_XCIN}	Feedback resistance	X _{CIN}			25.0		MΩ
V _{RAM}	RAM retention voltage		When clock is stopped	2.0			V
I _{CC}	Power supply current (V _{CC} =2.7 to 3.0V)	The output pins are open and other pins are V _{SS}	Flash memory version	f(X _{IN}) = 10MHz Square wave, no division	8	13	mA
			Flash memory version	f(X _{CIN}) = 32kHz Square wave, in RAM	25		μA
			Flash memory version	f(X _{CIN}) = 32kHz Square wave, in Flash	420		μA
			Flash memory version	f(X _{CIN}) = 32kHz When a WAIT instruction is executed.(Note 2) Oscillation capacity High	6.0		μA
				f(X _{CIN}) = 32kHz When a WAIT instruction is executed.(Note 2) Oscillation capacity Low	1.8		μA
	Topr = 25°C when clock is stopped		0.7	3.0	μA		
IDET4	VDET4 detection dissipation current (Note 3)			0.6	4	μA	
IDET3	Reset level detection dissipation current (Note 3)			0.4	2	μA	

Note 1: Specify a product of -40°C to 85°C to use it.

Note 2: With one timer operated using fc32.

Note 3: IDET is dissipation current when the following bit is set to "1" (detection circuit enabled).

IDET4: VC27 bit of VCR2 register

IDET3: VC26 bit of VCR2 register

$V_{CC} = 3V$ **Timing requirements**(referenced to $V_{CC} = 3V$, $V_{SS} = 0V$, at $T_{opr} = -20$ to $85^{\circ}C$ / -40 to $85^{\circ}C$ (*) unless otherwise specified)* : Specify a product of -40 to $85^{\circ}C$ to use it.**Table 1.18.25. External Clock Input (X_{IN} input)**

Symbol	Parameter	Standard		Unit
		Min.	Max.	
t_c	External clock input cycle time	100		ns
$t_{w(H)}$	External clock input HIGH pulse width	40		ns
$t_{w(L)}$	External clock input LOW pulse width	40		ns
t_r	External clock rise time		18	ns
t_f	External clock fall time		18	ns

$V_{CC} = 3V$ **Timing requirements**(referenced to $V_{CC} = 3V$, $V_{SS} = 0V$, at $T_{opr} = -20$ to $85^{\circ}C$ / -40 to $85^{\circ}C$ (*) unless otherwise specified)* : Specify a product of -40 to $85^{\circ}C$ to use it.**Table 1.18.26. Timer A input (counter input in event counter mode)**

Symbol	Parameter	Standard		Unit
		Min.	Max.	
$t_{c(TA)}$	TAiIN input cycle time	150		ns
$t_{w(TAH)}$	TAiIN input HIGH pulse width	60		ns
$t_{w(TAL)}$	TAiIN input LOW pulse width	60		ns

Table 1.18.27. Timer A input (gating input in timer mode)

Symbol	Parameter	Standard		Unit
		Min.	Max.	
$t_{c(TA)}$	TAiIN input cycle time	600		ns
$t_{w(TAH)}$	TAiIN input HIGH pulse width	300		ns
$t_{w(TAL)}$	TAiIN input LOW pulse width	300		ns

Table 1.18.28. Timer A input (external trigger input in one-shot timer mode)

Symbol	Parameter	Standard		Unit
		Min.	Max.	
$t_{c(TA)}$	TAiIN input cycle time	300		ns
$t_{w(TAH)}$	TAiIN input HIGH pulse width	150		ns
$t_{w(TAL)}$	TAiIN input LOW pulse width	150		ns

Table 1.18.29. Timer A input (external trigger input in pulse width modulation mode)

Symbol	Parameter	Standard		Unit
		Min.	Max.	
$t_{w(TAH)}$	TAiIN input HIGH pulse width	150		ns
$t_{w(TAL)}$	TAiIN input LOW pulse width	150		ns

Table 1.18.30. Timer A input (up/down input in event counter mode)

Symbol	Parameter	Standard		Unit
		Min.	Max.	
$t_{c(UP)}$	TAiOUT input cycle time	3000		ns
$t_{w(UPH)}$	TAiOUT input HIGH pulse width	1500		ns
$t_{w(UPL)}$	TAiOUT input LOW pulse width	1500		ns
$t_{su(UP-TIN)}$	TAiOUT input setup time	600		ns
$t_{h(TIN-UP)}$	TAiOUT input hold time	600		ns

Table 1.18.31. Timer A input (two-phase pulse input in event counter mode)

Symbol	Parameter	Standard		Unit
		Min.	Max.	
$t_{c(TA)}$	TAiIN input cycle time	2		μs
$t_{su(TAin-TAout)}$	TAiOUT input setup time	500		ns
$t_{su(TAout-TAin)}$	TAiIN input setup time	500		ns

V_{CC} = 3V**Timing requirements**(referenced to V_{CC} = 3V, V_{SS} = 0V, at T_{opr} = - 20 to 85°C / - 40 to 85°C (*) unless otherwise specified)

* : Specify a product of -40 to 85°C to use it.

Table 1.18.32. Timer B input (counter input in event counter mode)

Symbol	Parameter	Standard		Unit
		Min.	Max.	
t _c (TB)	TBiIn input cycle time (counted on one edge)	150		ns
t _w (TBH)	TBiIn input HIGH pulse width (counted on one edge)	60		ns
t _w (TBL)	TBiIn input LOW pulse width (counted on one edge)	60		ns
t _c (TB)	TBiIn input cycle time (counted on both edges)	300		ns
t _w (TBH)	TBiIn input HIGH pulse width (counted on both edges)	160		ns
t _w (TBL)	TBiIn input LOW pulse width (counted on both edges)	160		ns

Table 1.18.33. Timer B input (pulse period measurement mode)

Symbo	Parameter	Standard		Unit
		Min.	Max.	
t _c (TB)	TBiIn input cycle time	600		ns
t _w (TBH)	TBiIn input HIGH pulse width	300		ns
t _w (TBL)	TBiIn input LOW pulse width	300		ns

Table 1.18.34. Timer B input (pulse width measurement mode)

Symbo	Parameter	Standard		Unit
		Min.	Max.	
t _c (TB)	TBiIn input cycle time	600		ns
t _w (TBH)	TBiIn input HIGH pulse width	300		ns
t _w (TBL)	TBiIn input LOW pulse width	300		ns

Table 1.18.35. A-D trigger input

Symbol	Parameter	U	Standard		Unit
			Min.	Max.	
t _c (AD)	ADTRG input cycle time (trigger able minimum)		1500		ns
t _w (ADL)	ADTRG input LOW pulse width		200		ns

Table 1.18.36. Serial I/O

Symbol	Parameter	Standard		Unit
		Min.	Max.	
t _c (CK)	CLKi input cycle time	300		ns
t _w (CKH)	CLKi input HIGH pulse width	150		ns
t _w (CKL)	CLKi input LOW pulse width	150		ns
t _d (C-Q)	TxDi output delay time		160	ns
t _h (C-Q)	TxDi hold time	0		ns
t _{su} (D-C)	RxDi input setup time	50		ns
t _h (C-D)	RxDi input hold time	90		ns

Table 1.18.37. External interrupt INTi inputs

Symbo	Parameter	Standard		Unit
		Min.	Max.	
t _w (INH)	INTi input HIGH pulse width	380		ns
t _w (INL)	INTi input LOW pulse width	380		ns

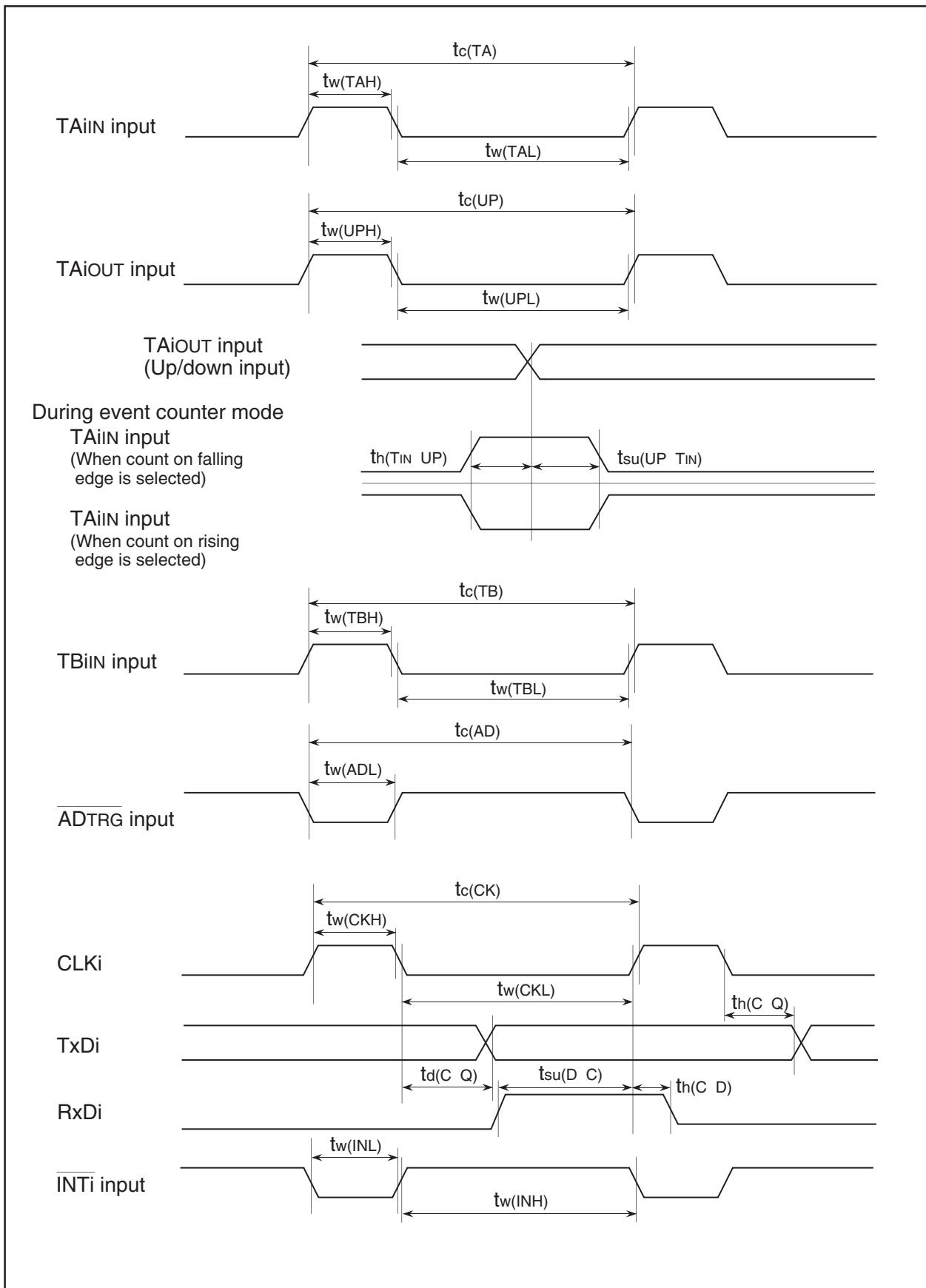

Figure 1.18.1. Timing diagram (1)

Outline Performance

Table 1.19.1 shows the outline performance of the M16C/26 (flash memory version).

Table 1.19.1. Outline performance of the M16C/26 (flash memory version)

Item		Performance
Flash memory operation mode		Three user modes (standard serial I/O, CPU rewrite, parallel I/O)
Erase block division	User ROM area	See Figure 1.19.1
Write method		In units of word.
Erase method		Block erase
Erase/Write (E/W) control method		E/W control by software command
Protect method		Two 8Kbyte user by register lock bit (FMR02)
Number of commands		5 commands
Erase/Write count (Notes 1, 2)		Depends on device code (see Table 1.2b)
Data Retention		10 years
ROM code protect		Parallel I/O and standard serial I/O modes are supported.

Note 1: Block A and Block B are 10,000 times E/W. All other blocks are 1000 times E/W. (Under development; mass production scheduled to start in the 3rd quarter of 2003.)

Note 2: Definition of E/W times:

The E/W times are defined to be per-block erasure times. For example, assume a case whereby a 4-Kbyte Block A is programmed one word at a time and erased once all 2048 write operations have completed. In this case, the block is considered to have been written and erased once. If a product is 100 times E/W, each block in it can be erased up to 100 times. When 10,000 times E/W, Block A and Block B can each be erased up to 10,000 times. All other blocks can each be erased up to 1000 times.

Flash Memory

The M16C/26 (flash memory version) contains the flash memory that can be rewritten with a single voltage. For this flash memory, three flash memory modes are available in which to read, program, and erase: parallel I/O and standard serial I/O modes in which the flash memory can be manipulated using a programmer and a CPU rewrite mode in which the flash memory can be manipulated by the Central Processing Unit (CPU). Each mode is detailed in the following sections.

The flash memory is divided into several blocks as shown in Figure 1.19.1, so that memory can be erased one block at a time.

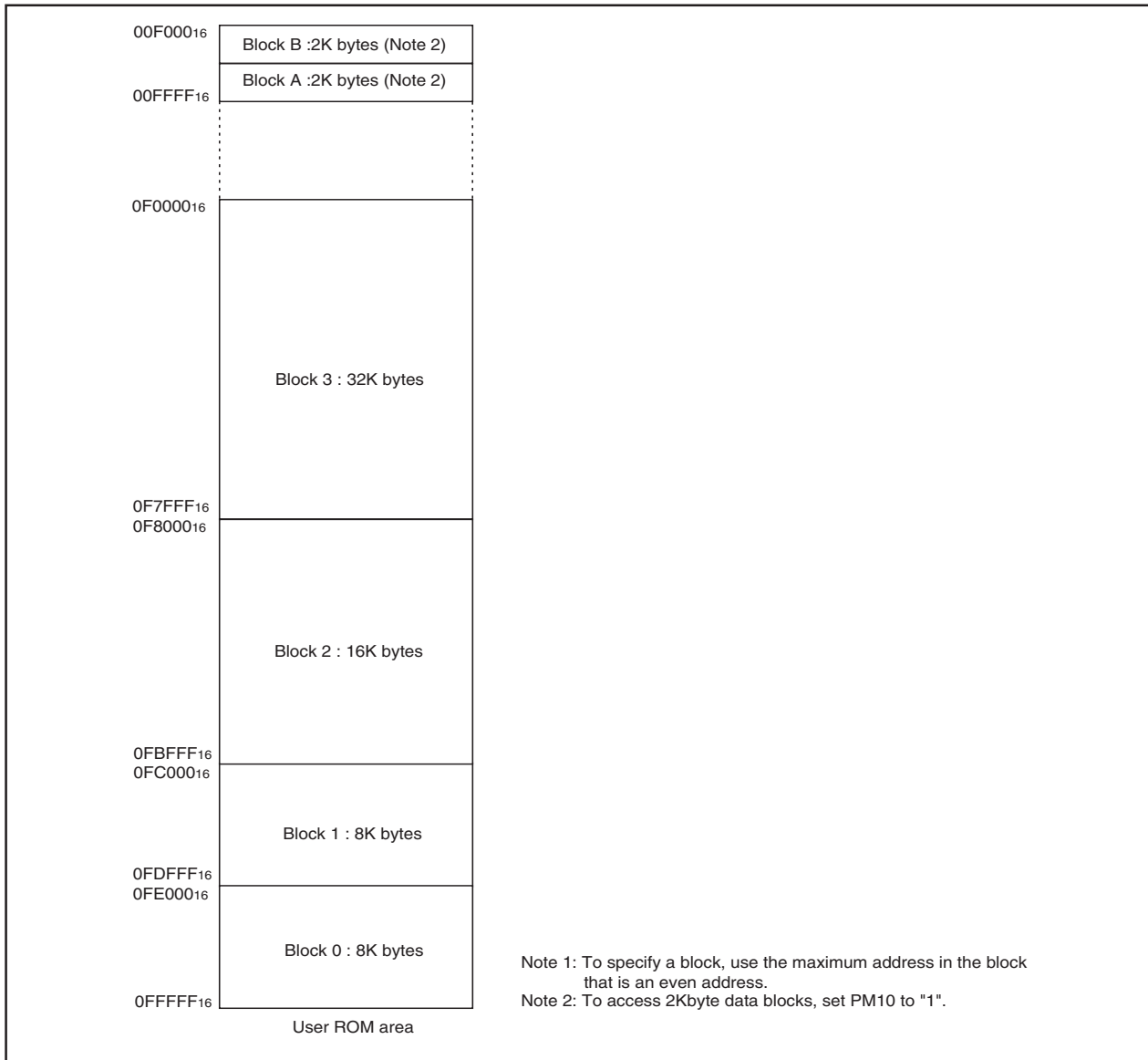

Figure 1.19.1. Block diagram of flash memory (64-Kbyte) version (Note 1)

CPU Rewrite Mode

The CPU rewrite mode is used to perform a read, program, or erase operation on the internal flash memory under control by the central processing unit (CPU). There are two variations of this mode: erase write 0 mode (EW0) in which said operation is performed using a rewrite program residing in memory (i.e. RAM) other than the internal flash memory and erase write 1 mode (EW1) in which said operation is performed using the program residing in the internal flash memory.

In CPU rewrite mode, only the user ROM area shown in Figure 1.19.1 can be rewritten. The Program and Block Erase commands can be executed only for the user ROM area in block intervals.

The EW0 mode control program must be stored in the user ROM area. In EW0 mode, because the flash memory cannot be read from the CPU, the rewrite control program must be transferred to memory locations other than the internal flash memory before it can be executed.

The EW1 mode control program must be stored in the user ROM area. In this mode, the rewrite control program does not have to be transferred to other memory locations before executing it. However, in this mode, the block where the rewrite control program is stored cannot be operated on by the Program or Erase commands.

User Mode and Boot Mode

The control program for CPU rewrite mode must be written into the user ROM area, in parallel I/O mode, beforehand.

Normal user mode is entered when the microcomputer is reset with pulling CNVss pin low. In this case, the CPU starts operating using the control program in the user ROM area.

When the microcomputer is reset by pulling both the CNVss and the P86 $\overline{[CE]}$ pins high, the CPU starts operating using the standard serial I/O control program. This mode is called the "boot" mode. When reset is deasserted in boot mode, be sure the P65 pin is not at high or the P67 pin is not at low.

Block Address

Block addresses refer to an even address of each block. These addresses are used in the block erase command.

Outline Performance (CPU Rewrite Mode)

In the CPU rewrite mode, the CPU erases, programs and reads the internal flash memory as instructed by software commands. There are two variations of this mode: erase write 0 mode (EW0) where operation is executed in other than the internal flash memory such as the internal RAM and erase write 1 mode (EW1) where operation is executed in the internal flash memory. One-wait must be set in both modes.

EW0 mode (CPU rewrite mode)

In this mode, the program must be executing out of RAM. The microcomputer is placed in EW0 mode by setting the CPU rewrite mode select bit (address 01B716, bit 1) to 1, becoming ready to accept software

commands.

In CPU rewrite mode (whether EW0 or EW1), make sure all software commands and data are written to and read from even addresses (byte address $A_0 = 0$) in 16 bit units. Make sure the write data is written in 16 bit units beginning with an even address. Writing in 16 bit units beginning with an odd address and writing in 8 bit units are inhibited. When using 8-bit software commands, always be sure to write to even addresses. Writing to odd addresses has no effect.

Use software commands to control program and erase operations. Whether program and erase operations have terminated normally or in error can be verified by reading the status register. Even when reading the status register, set to even addresses in the user ROM area also.

EW1 mode (CPU rewrite mode)

In EW1 mode, operation is executed using the control program residing in the internal flash memory. Unlike in EW0 mode, there is no need to transfer the control program to other than the internal flash memory (e.g., internal RAM). However, make sure the control program is located in the 64-Kbyte user block or 4-Kbyte data block.

For EW1 mode, set the EW0 mode select bit (address 01B716, bit 1) to 1 (by writing 0 and then 1 in succession) and set the EW1 mode select bit (address 01B516, bit 6) to 1 (by writing 0 and then 1 in succession). This places the microcomputer in EW1 mode, ready to accept software commands. Although software commands operate the same way as in EW0 mode, there are following differences.

- (1) Do not perform Block Erase or Program operations on control program execution blocks (blocks in which the control program is located).
- (2) Do not execute the Read Status Register command. (In EW1 mode, this command has no effect.) After erase and program operations are completed during EW1 mode, the microcomputer is in read array mode, and not in read status mode. (During EW0 mode, the microcomputer is in read status mode after operations are completed.)

Therefore, to verify whether program or erase operations have terminated normally or in error, read the flash memory control register 0. Be aware that during EW1 mode, the status register cannot be read.

During EW1 mode, the CPU remains in a hold state while executing erase and program operations. The ports retain the status in which they were before commands were issued. (They do not go Hi-Z even while executing erase or program operations.)

After erase or program operations are completed, the CPU restarts execution of the rest of the control program.

While erase or program operations are underway in EW1 mode, make sure that no interrupts except NMI, watchdog timer, and reset will be generated, and that no DMA transfers will be committed.

Erase-Suspend Feature

The M16C/26 Flash ROM has been designed to be more compact and require a smaller layout footprint. This, as a result, causes longer erase times. The M16C/26 Flash ROM is however not available/accessible during an erase operation. This may sometimes cause time critical interrupt driven operations requiring data/program in the flash to not be satisfied during the erase operation.

To circumvent this issue, the M16C/26 Flash ROM offers a new 'erase-suspend' feature which allows the erase operation to be suspended, and access made available to the flash. The erase operation may subsequently be resumed via software.

There are CPU erase/write (CPUEW) modes available EW0 (execution out of RAM) and EW1 (execution out of FLASH). The erase-suspend feature is different in each of these modes. Please note that 1-wait needs to be set in CPUEW operations.

EW0:

In EW0, program code is executed out of the RAM. After the erase command has been executed, program execution continues in the RAM. As stated earlier the FLASH is not accessible during an erase operation. If there is a request for data/code from the FLASH (via a maskable peripheral/external interrupt), the interrupt must first request an erase-suspend. This is achieved by setting bits FMR40 (SUSPEND_ENABLE) and FMR41 (SUSPEND_REQUEST). The routine then polls FMR46 (SUSPENDL) until it is set. At this point the erase has been suspended and the flash is accessible. Once the required accesses are complete FMR41 (SUSPEND_REQUEST) is cleared and the routine is completed. The erase operation resumes and continues to completion or until another erase-suspend request occurs.

User actions:

- 1.0 Execute erase command out of RAM.
- 2.0 Maskable Interrupt request.
 - 2.1 Set FMR40 & FMR41.
 - 2.2 Poll FMR46 until '1'.
 - 2.3 Access flash data/code.
 - 2.4 Clear FMR41.
 - 2.5 Return
- 3.0 Continue execution out of RAM

FMR40 may also be set before the erase command is executed, instead of in the interrupt routine.

EW1:

In EW1, program code is executed out of the FLASH. First FMR40 (SUSPEND_ENABLE) must be set to allow the erase-suspend feature. After the erase command is executed the CPU goes into HOLD. A maskable interrupt will set FMR41 (SUSPEND_REQUEST) if in an erase operation. Once the erase is suspended the HOLD is deasserted and execution from the FLASH continues. The interrupt routine can now be serviced, after which control is returned to the main program. If the SUSPEND_REQUEST has been set, it should be cleared, and when the erase resumes the CPU goes back into HOLD until the erase operation is complete or another interrupt occurs.

User actions:

- 1.0 Set FMR40
- 2.0 Execute erase command out of FLASH.
- 3.0 HOLD_POINT (in HOLD)
- 4.0 Maskable Interrupt request. (FMR41 set by h/w)
 - 4.1 Access flash data/code.
 - 4.2 Return
- 5.0 if FMR41 is set, clear FMR41, jump to HOLD_POINT.
- 6.0 Continue execution out of FLASH.

Register Description

Figure 1.20.1 shows the flash identification register, flash memory control register 0 and flash memory control register 1.

Flash memory control register 0 (FMR0):

Bit 0 of the flash memory control register 0 is the RY/BY status flag used exclusively to read the operating status of the flash memory. During programming, erase, and erase-suspend operations, it is "0". Otherwise, it is "1".

Bit 1 of the flash memory control register 0 is the CPU rewrite mode select bit. The CPU rewrite mode is entered by setting this bit to "1", so that software commands become acceptable. To set this bit to "1", it is necessary to write "0" and then write "1" in succession. To set this bit to "0" by only writing a "0".

Bit 2 of the flash memory control register 0 allows program and erase operations to occur on the two 8K byte user blocks. When this bit is set to "0", no program or erase operations can occur on these blocks. To permit program and erase operations to occur on these blocks, set this bit to a "1". To set this bit to "1", it is necessary to write "0" and then write "1" in succession. This bit can be manipulated only when the CPU rewrite mode select bit = "1" (Bit 1 of this register).

Bit 3 of the flash memory control register is the flash memory reset bit used to reset the control circuit of the internal flash memory. This bit is used when exiting CPU rewrite mode and when flash memory access has failed. When the CPU rewrite mode select bit is "1", writing "1" for this bit resets the control circuit. To release the reset, it is necessary to set this bit to "0" when RY/BY status flag is "1". Also when this bit is set to "1", power is not supplied to the internal flash memory, thus power consumption can be reduced. However, in this state, the internal flash memory cannot be accessed. To set this bit to "1", it is necessary to write "0" and then write "1" in succession when the CPU rewrite mode select bit is "1". Use this bit mainly in the low speed mode (when XCIN is the count source of BCLK).

It is not particularly necessary to set bit 3 of the flash memory control register 0 on return from STOP/WAIT.

Figure 1.20.2c shows a flowchart for shifting to the low power dissipation mode. Always perform operation as indicated in these flowcharts.

Bit 6 of the flash memory control register 0 is the program status flag used exclusively to read the operating status of the auto program operation. If a program error occurs, it is set to "1". Otherwise, it is "0".

Bit 7 of the flash memory control register 0 is the erase status flag used exclusively to read the operating status of the auto erase operation. If an erase error occurs, it is set to "1". Otherwise, it is "0".

Figure 1.20.2a shows a EW0 mode set/reset flowchart, figure 1.20.2b shows a EW1 mode set/reset flowchart. Always perform operation as indicated in these flowcharts.

Flash memory control register 1 (FMR1):

Bit 1 allows the user to enter EW1 mode. This bit is relevant only if bit FMR01 is set.

Bit 7, when set to "0", inserts one wait state per access to Block A or B - regardless of the value of PM17. Wait state insertion during access to all other blocks, as well as to internal RAM, is controlled by PM17 - regardless of the setting of FMR17. In cases where E/W cycles to Block A or B exceed 100 times (D7, D9, U7, U9), please set FMR17 to "1" (with wait).

Flash memory control register 4 (FMR4):

Bit 0 must be set to enable the erase-suspend feature.

Bit 1 is to be used to request a suspend of an erase operation. This bit is set automatically in EW1 by a maskable interrupt, and by software in EW0. This bit is to be always cleared by software at the end of the erase suspend.

Bit 6 indicates suspend status. Poll this bit in EW0 after requesting a suspend, before accessing the flash.

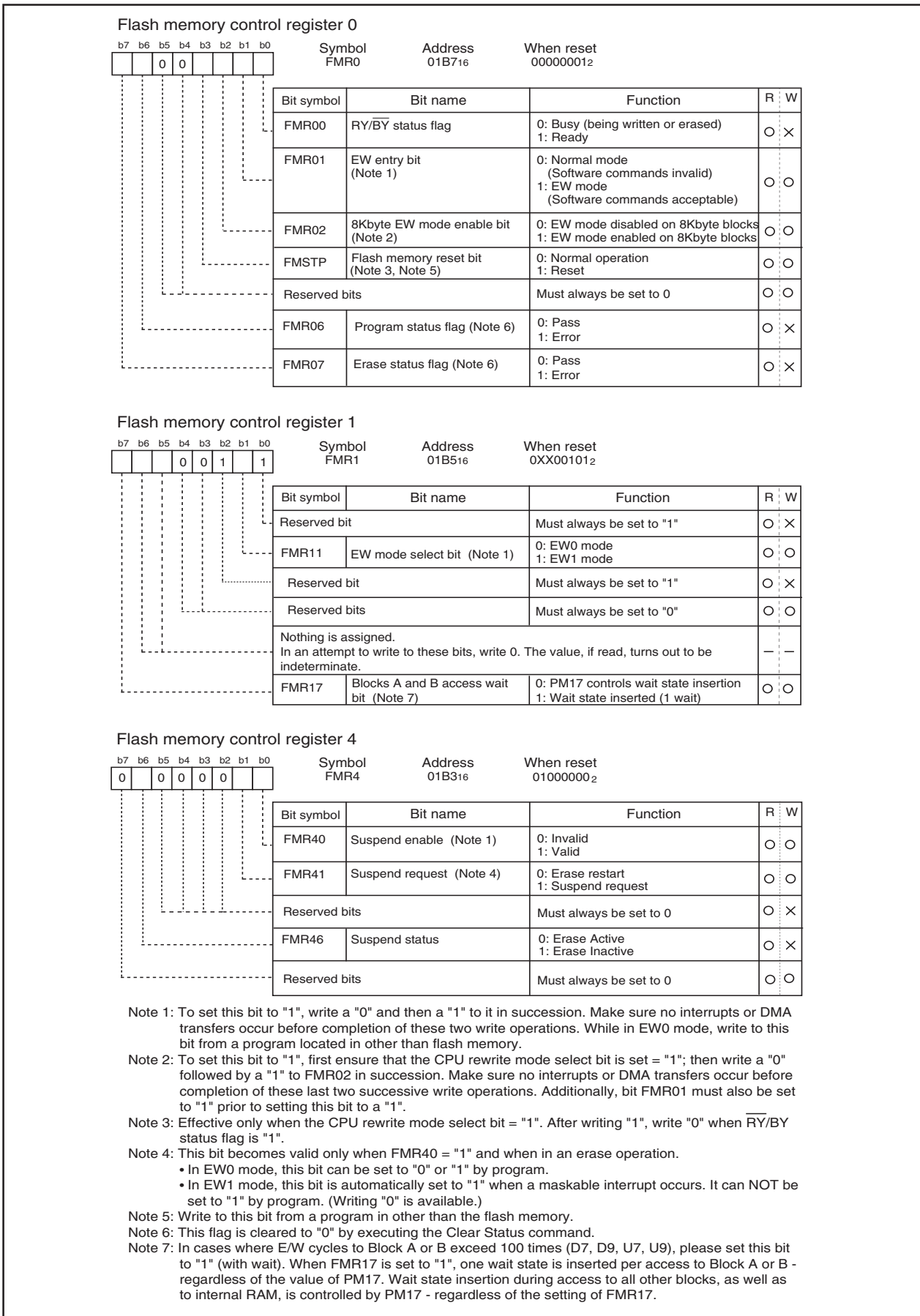

Figure 1.20.1. Flash memory control registers 0, 1

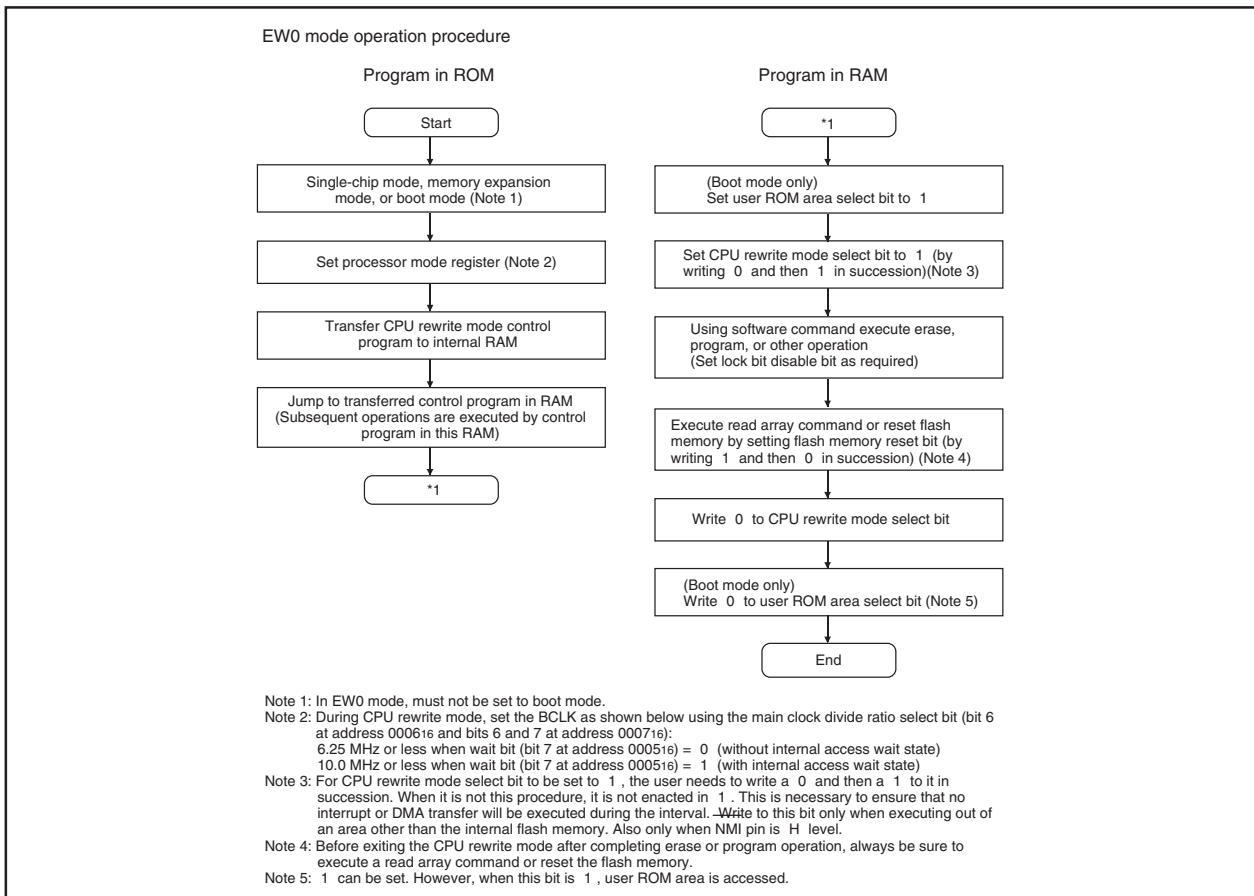

Figure 1.20.2a. EW0 mode set/reset flowchart

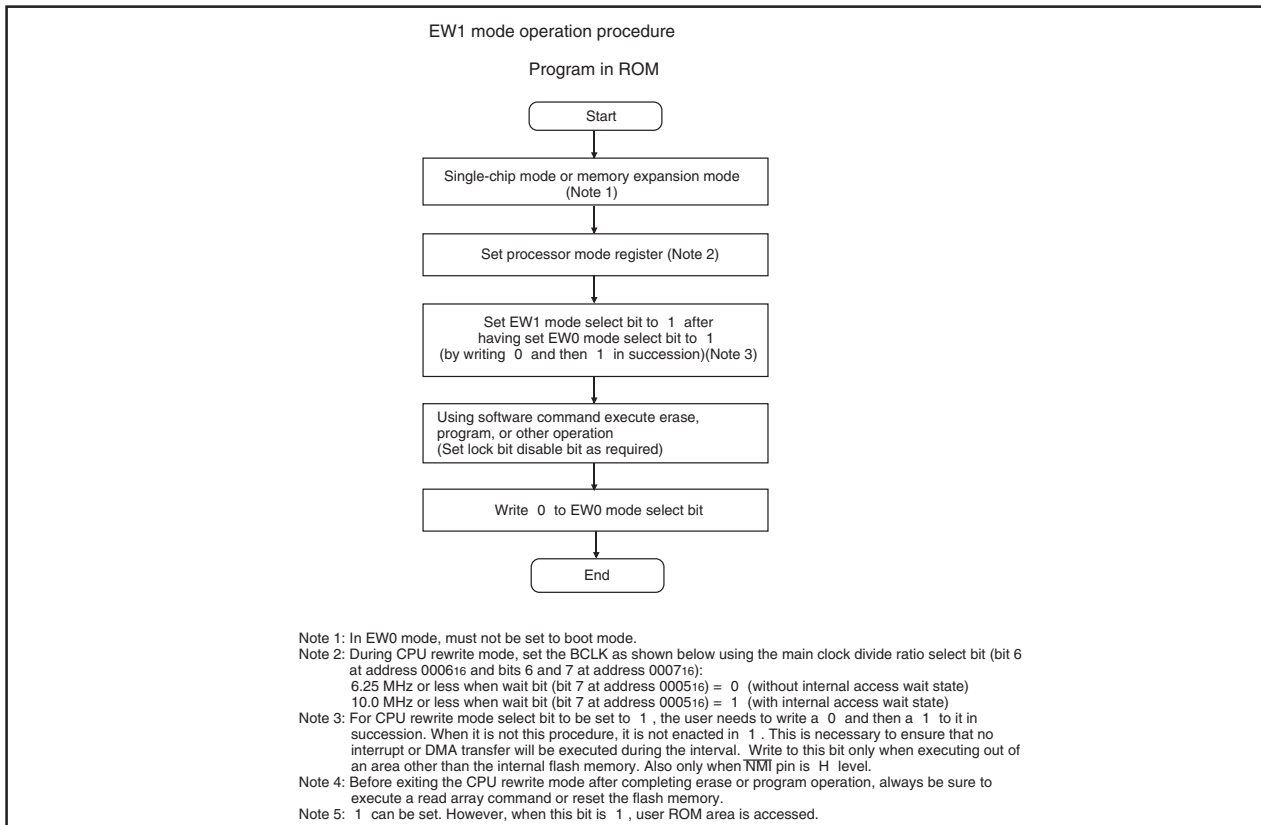

Figure 1.20.2b. EW1 mode set/reset flowchart

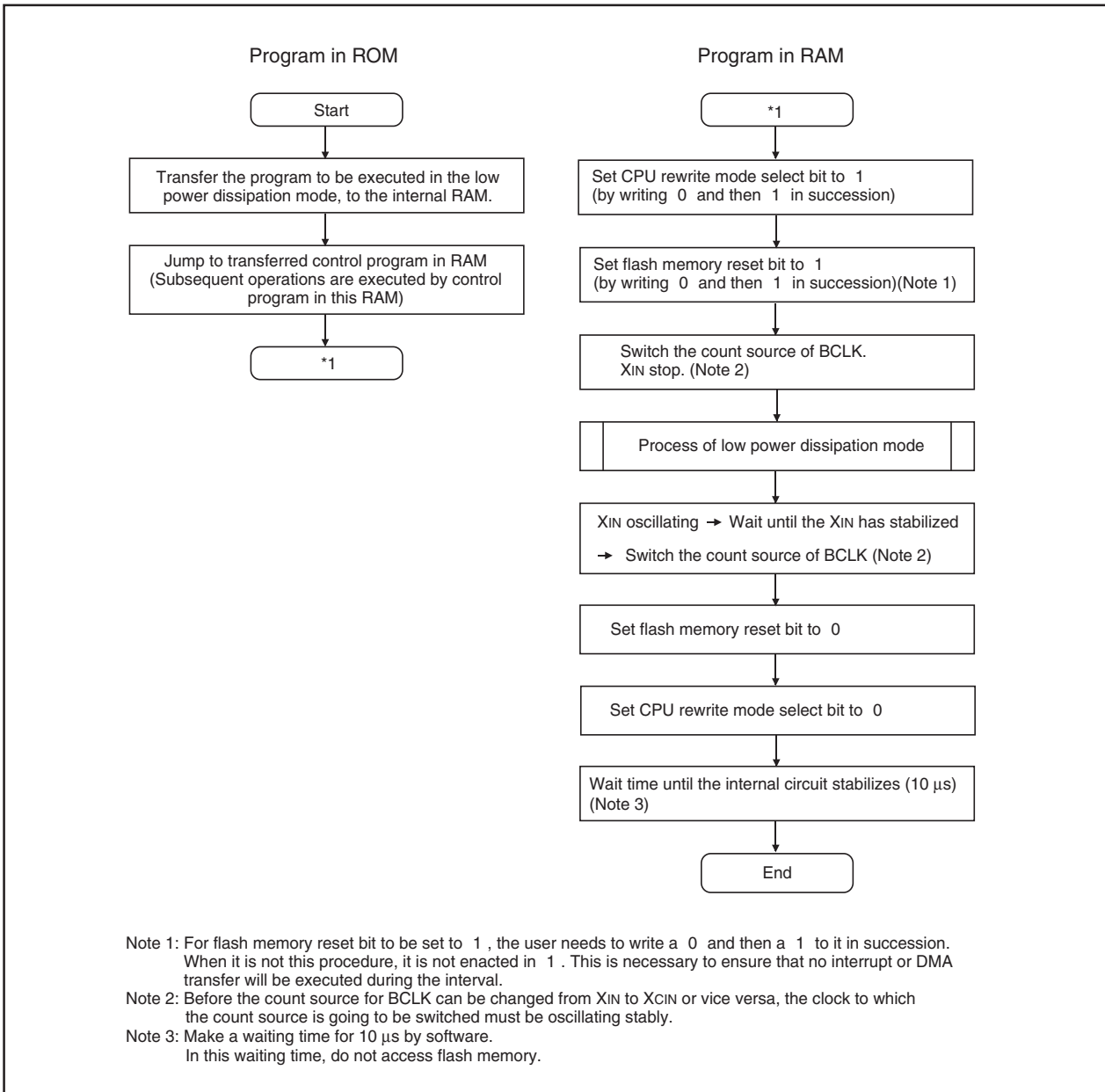

Figure 1.20.2c. Shifting to the low power dissipation mode flowchart

Precautions on CPU Rewrite Mode

Described below are the precautions to be observed when rewriting the flash memory in CPU rewrite mode.

(1) Operation speed

During CPU rewrite mode (EW0/EW1 mode), set the BCLK as shown below using the main clock divide ratio select bit (bit 6 at address 0006₁₆ and bits 6 and 7 at address 0007₁₆):

10.0 MHz or less when wait bit (bit 7 at address 0005₁₆) = 1 (with internal access wait state)

Note : Always perform it with a condition mentioned above.

(2) Instructions inhibited against use

The instructions listed below cannot be used during EW0 mode because they refer to the internal data of the flash memory:

UND instruction, INTO instruction, JMPS instruction, JSRS instruction, and BRK instruction

(3) Interrupts inhibited against use

The address match interrupt cannot be used during EW0 mode because they refer to the internal data of the flash memory. If interrupts have their vector in the variable vector table, they can be used by transferring the vector into the RAM area. The NMI and watchdog timer interrupts can be used to automatically initialize the flash identification register and flash memory control register 0 to "0", then return to normal operation. However, these two interrupts' jump addresses are located in the fixed vector table and there must exist a routine to be executed. Since the rewrite operation is halted when an NMI or watchdog timer interrupts occurs, you must reset the CPU rewrite mode select bit to "1" and then perform the erase/program operation again.

(4) How to access

For EW0 mode select bit and lock bit disable select bit to be set to "1", the user needs to write a "0" and then a "1" to it in succession. When it is not this procedure, it is not enacted in "1". This is necessary to ensure that no interrupt or DMA transfer will be executed during the interval. Also only when NMI pin is "H" level.

(5) Writing in the user ROM area

If power is lost while rewriting blocks that contain the flash rewrite program with the CPU rewrite mode, those blocks may not be correctly rewritten and it is possible that the flash memory can no longer be rewritten after that. Therefore, it is recommended to use the standard serial I/O mode or parallel I/O mode to rewrite these blocks.

(6) STOP/WAIT

Both instructions disrupt erase/program operation, and the state of the blocks operated upon is not guaranteed. Inhibit these instructions when in CPU rewrite mode.

Software Commands

Table 1.20.1 lists the software commands available with the M16C/26 (flash memory version).

After setting the CPU rewrite mode select bit to 1, write a software command to specify an erase or program operation. Note that when entering a software command, the upper byte (D8 to D15) is ignored.

The content of each software command is explained below.

The first bus cycle commands must be written to an even address in the user ROM area.

Table 1.20.1. List of software commands (CPU rewrite mode)

Command	First bus cycle			S econd bus cycle		
	Mode	Address	Data (D ₀ to D ₇)	Mode	Address	Data (D ₀ to D ₇)
Read array	Write	X	FF ₁₆			
Read status register	Write	X	70 ₁₆	Read	X	SRD (Note 2)
Clear status register	Write	X	50 ₁₆			
Program (Note 3)	Write	WA	40 ₁₆	Write	WA (Note 3)	WD (Note 3)
Block erase	Write	X	20 ₁₆	Write	BA (Note 4)	D0 ₁₆

Note 1: When a software command is input, the high-order byte of data (D8 to D15) is ignored.

Note 2: SRD = Status Register Data (Set an address to even address in the user ROM area)

Note 3: WA = Write Address (even address), WD = Write Data (16-bit data)

Note 4: BA = Block Address (Enter the maximum address of each block that is an even address.)

Note 5: X denotes a given address in the user ROM area (that is an even address).

Read Array Command (FF₁₆)

The read array mode is entered by writing the command code "FF₁₆" in the first bus cycle. When an even address to be read is input in one of the bus cycles that follow, the content of the specified address is read out at the data bus (D₀–D₁₅), 16 bits at a time.

The read array mode is retained intact until another command is written.

However, please begin to read data in the following procedures when a user uses read array command after program command.

- (1) Set FF₁₆, FF₁₆, FF₁₆, FF₁₆ to arbitrary continuing four address beforehand
- (2) Input the top address which FF₁₆ was set at (in read array mode)
- (3) Input the top address till FFFF₁₆ agrees with the value that begins to have been read
- (4) Input top address +2
- (5) Input top address +2 till FFFF₁₆ agrees with the value that begins to have been read
- (6) Input an arbitrary address

Read Status Register Command (70₁₆)

When the command code "70₁₆" is written in the first bus cycle, the content of the status register is read out at the data bus (D₀–D₇) by a read in the second bus cycle (Set an address to even address in the user ROM area).

The status register is explained in the next section.

In EW1 mode, cannot use read status register command.

Clear Status Register Command (50₁₆)

This command is used to clear the bits SR4 and SR5 of the status register after they have been set. These bits indicate that operation has ended in an error. To use this command, write the command code "50₁₆" in the first bus cycle.

Program Command (40₁₆)

Program operation starts when the command code “40₁₆” is written in the first bus cycle. Then, if the address and data to program are written in the 2nd bus cycle, program operation (data programming and verification) will start. Make an address in the first bus cycle same as an address to program by the second bus cycle.

Whether the write operation is completed can be confirmed by reading the status register or the RY/BY status flag. When the program starts, the read status register mode is accessed automatically and the content of the status register is read into the data bus (D0 - D7). The status register bit 7 (SR7) is set to 0 at the same time the write operation starts and is returned to 1 upon completion of the write operation. In this case, the read status register mode remains active until the Read Array command (FF₁₆) is written.

The RY/BY status flag is 0 during write operation and 1 when the write operation is completed as is the status register bit 7.

At program end, program results can be checked by reading the status register.

Figure 1.20.3 shows an example of a program flowchart.

Each block of the flash memory can be write protected by using a lock bit. For details, refer to the section where the data protect function is detailed.

Additional writes to the already programmed pages are prohibited.

Do a command to use in right after of program command as follows

Make an address in the first bus cycle same as an address to program by the second bus cycle of program command.

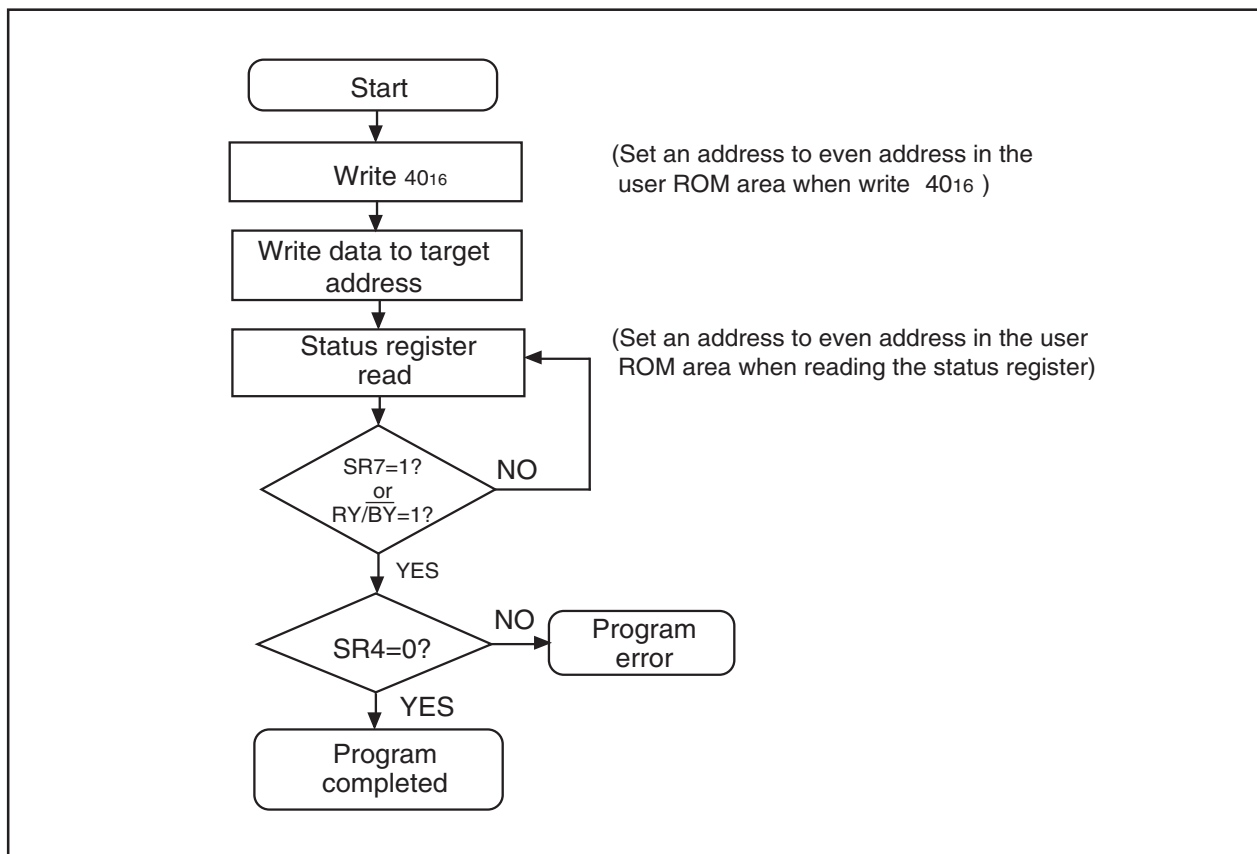

Figure 1.20.3. Program flowchart

Block Erase Command (2016/D016)

By writing the command code “2016” in the first bus cycle and the confirmation command code “D016” in the second bus cycle that follows to the block address of a flash memory block, the system initiates an auto erase (erase and erase verify) operation.

Whether the auto erase operation is completed can be confirmed by reading the status register or the flash memory control register 0. At the same time the auto erase operation starts, the read status register mode is automatically entered, so the content of the status register can be read out. The status register bit 7 (SR7) is set to 0 at the same time the auto erase operation starts and is returned to 1 upon completion of the auto erase operation. In this case, the read status register mode remains active until the Read Array command (FF16) or Read Lock Bit Status command (7116) is written or the flash memory is reset using its reset bit.

The RY/BY status flag of the flash memory control register 0 is 0 during auto erase operation and 1 when the auto erase operation is completed as is the status register bit 7.

After the auto erase operation is completed, the status register can be read out to know the result of the auto erase operation. For details, refer to the section where the status register is detailed.

Figure 1.20.4 shows an example of a block erase flowchart.

Each block of the flash memory can be protected against erasure by using a lock bit. For details, refer to the section where the data protect function is detailed.

During EW1 mode, do not execute this command on blocks in which the control program is stored.

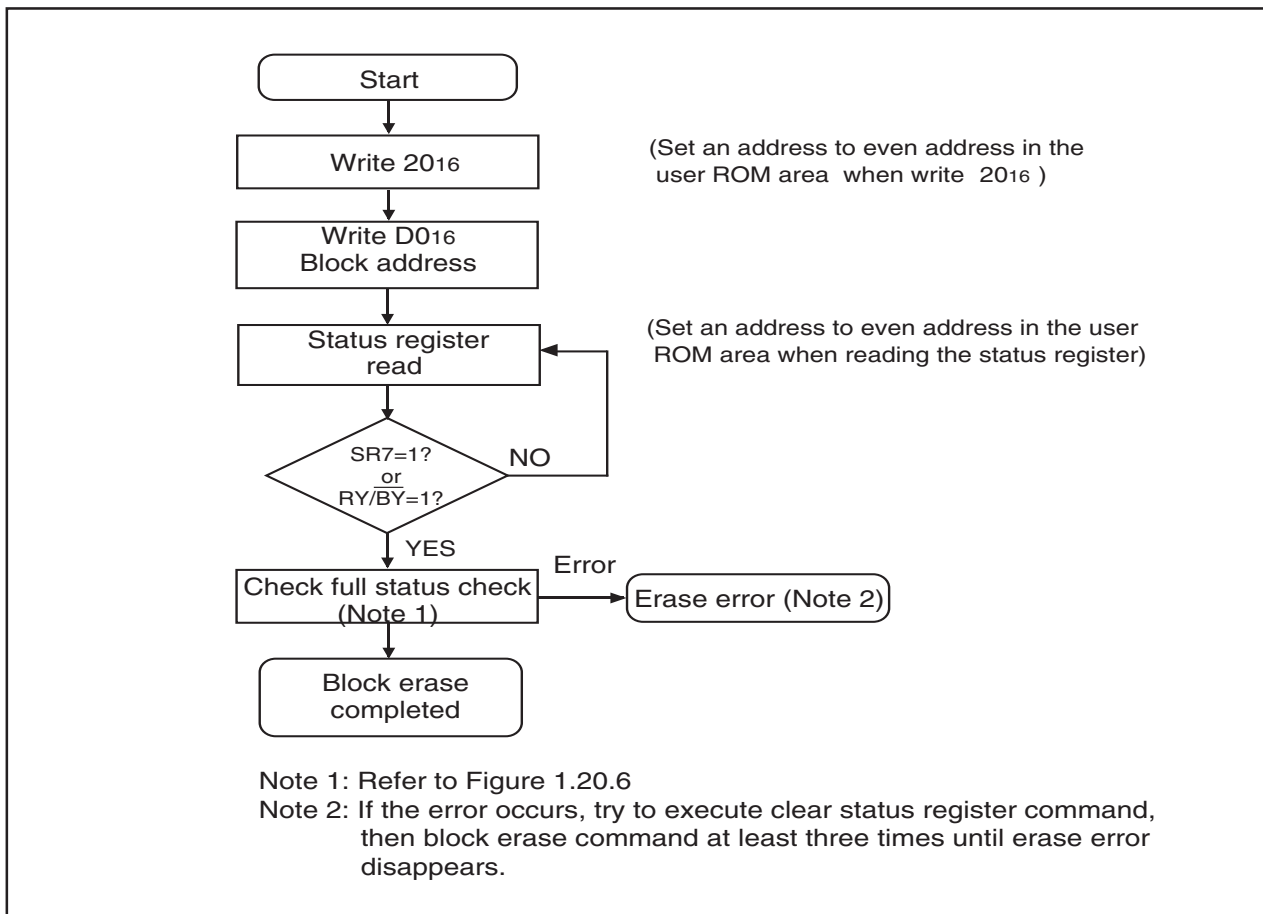

Figure 1.20.4. Block erase flowchart

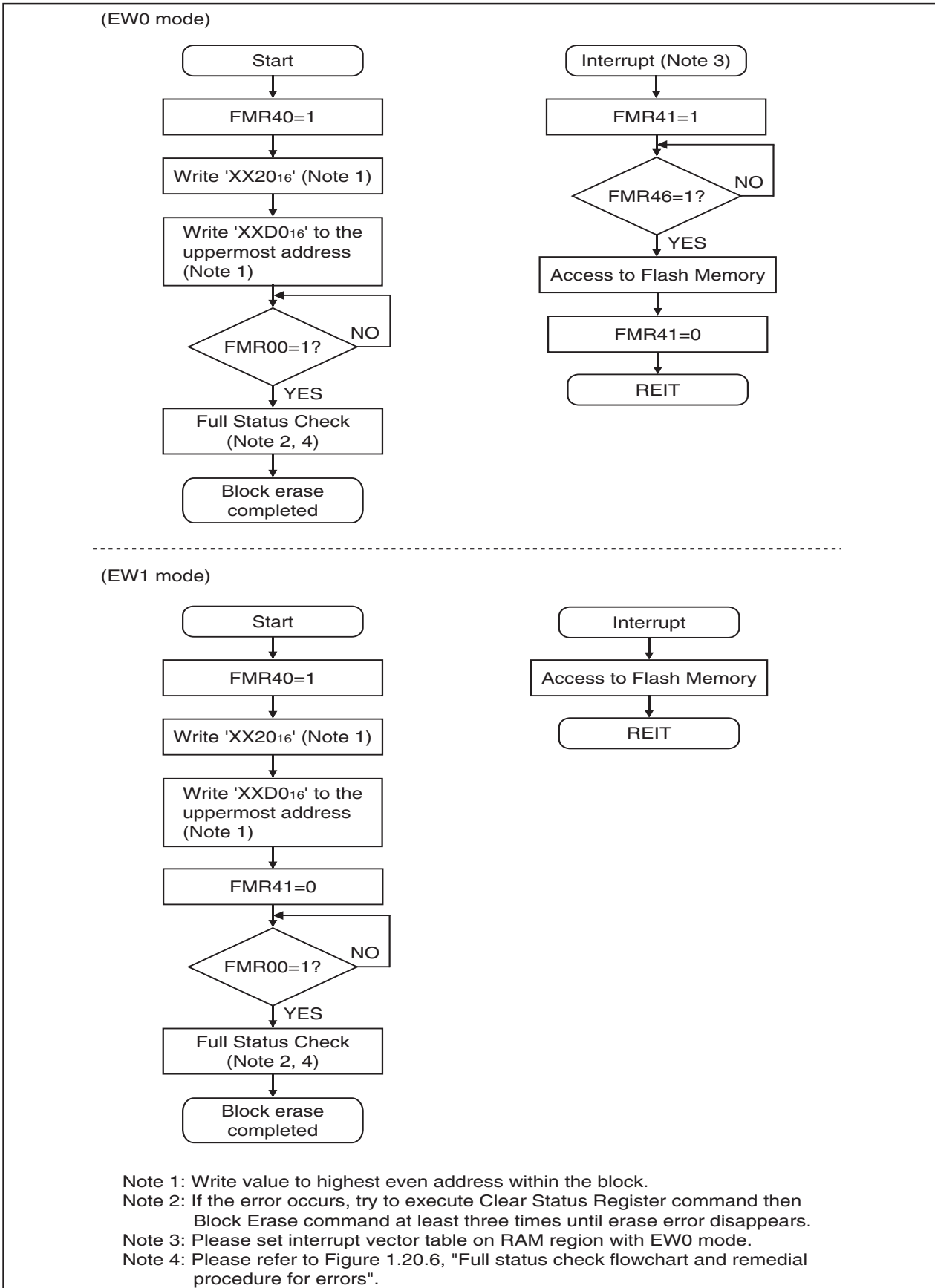

Figure 1.20.5. Block erase flowchart with erase suspend function

Status Register

The status register shows the operating state of the flash memory and whether erase operations and programs ended successfully or in error. It can be read only in the EW0 mode, in the following ways. The status cannot be read out in the EW1 mode and during suspend.

- (1) By reading an arbitrary even address from the user ROM area after writing the read status register command (70₁₆)
- (2) By reading an arbitrary even address from the user ROM area in the period from when the program starts or erase operation starts to when the read array command (FF₁₆) is input

Table 1.20.2 shows the status register.

In the EW1 mode, the status corresponding to the below is stored in the flash memory control register 0. Read this register for status check.

Also, the status register can be cleared in the following way.

- (1) By writing the clear status register command (50₁₆)

After a reset, the status register is set to "80₁₆".

Each bit in this register is explained below.

Sequencer status (SR7) / FMR00

After power-on, the sequencer status is set to 1 (ready).

The sequencer status indicates the operating status of the device. This status bit is set to "0" (busy) during write or erase operation and is set to "1" upon completion of these operations.

Erase status (SR5) / FMR07

The erase status informs the operating status of erase operation to the CPU. When an erase error occurs, it is set to "1".

The erase status is reset to "0" when cleared.

Program status (SR4)

The program status informs the operating status of write operation to the CPU. When a write error occurs, it is set to "1".

The program status is reset to "0" when cleared.

When an erase command is in error (which occurs if the command entered after the block erase command (20₁₆) is not the confirmation command (D0₁₆), both the program status and erase status (SR5) are set to "1".

When the program status or erase status = "1", only the following flash commands will be accepted: Read Array, Read Status Register, and Clear Status Register.

Also, in one of the following cases, both SR4 and SR5 are set to 1 (command sequence error):

- (1) When the valid command is not entered correctly
- (2) When the data entered in the second bus cycle of lock bit program (77₁₆/D0₁₆), block erase (20₁₆/D0₁₆), or erase all unlock blocks (A7₁₆/D0₁₆) is not the D0₁₆ or FF₁₆. However, if FF₁₆ is entered, read array is assumed and the command that has been set up in the first bus cycle is canceled.

Table 1.20.2. Definition of each bit in status register

Each SRD bit	Status name	Definition	
		"1"	"0"
SR7 (D ₇)	Write state machine (WSM)	Ready	Busy
SR6 (D ₆)	Reserved	–	–
SR5 (D ₅)	Erase status	Terminated in error	Terminated normally
SR4 (D ₄)	Program status	Terminated in error	Terminated normally
SR4 (D ₃)	Program status after program	Terminated in error	Terminated normally
SR2 (D ₂)	Reserved	–	–
SR1 (D ₁)	Reserved	–	–
SR0 (D ₀)	Reserved	–	–

Full Status Check

By performing full status check, it is possible to know the execution results of erase and program operations. Figure 1.20.6 shows a full status check flowchart and the action to be taken when each error occurs.

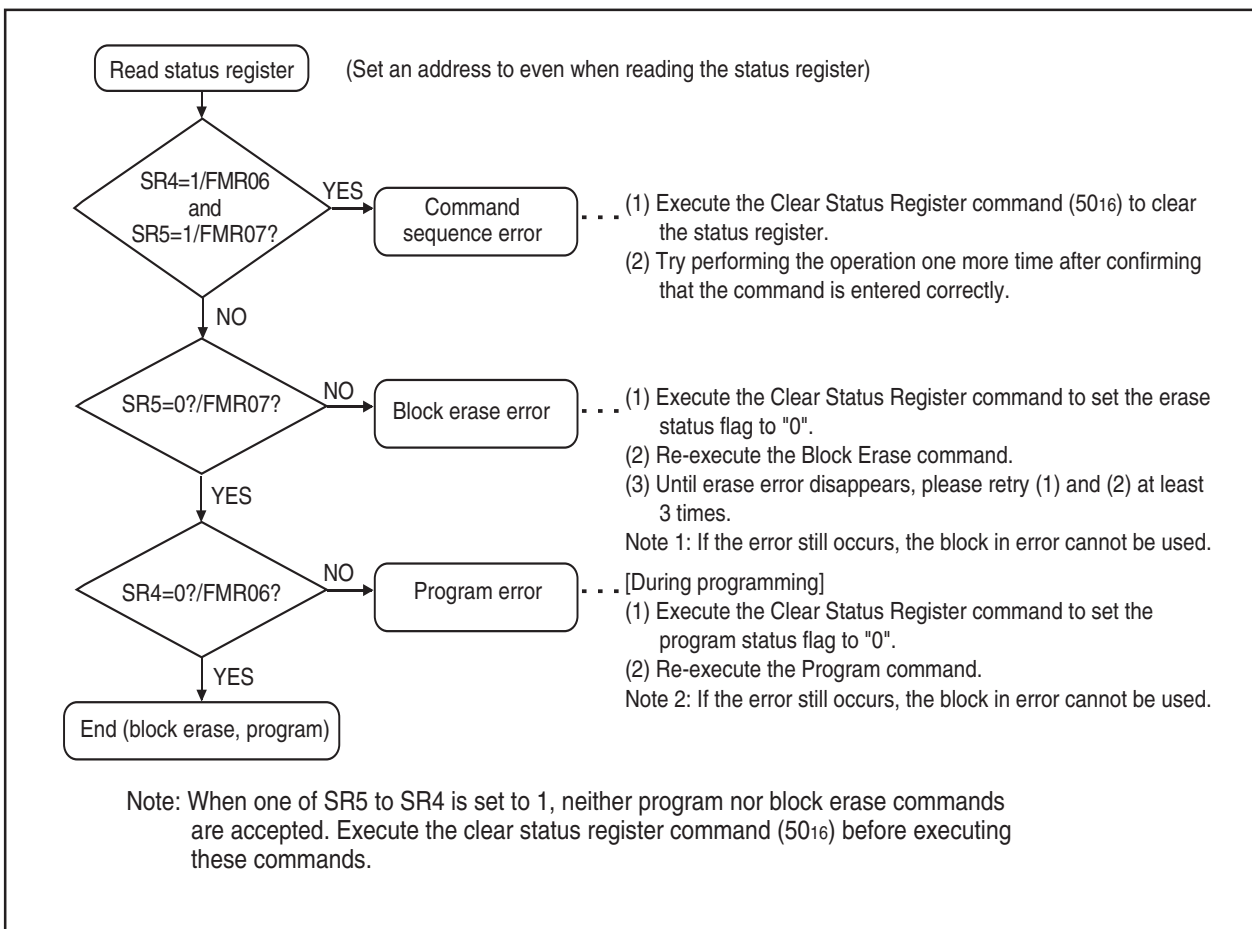

Figure 1.20.6. Full status check flowchart and remedial procedure for errors

Functions To Inhibit Rewriting Flash Memory Version

To prevent the contents of the flash memory version from being read out or rewritten easily, the device incorporates a ROM code protect function for use in parallel I/O mode and an ID code check function for use in standard serial I/O mode.

ROM code protect function

The ROM code protect function is used to prohibit reading out or modifying the contents of the flash memory during parallel I/O mode and is set by using the ROM code protect control address register (0FFFFFF₁₆). Figure 1.21.1 shows the ROM code protect control address (0FFFFFF₁₆). (This address exists in the user ROM area.)

If either bit of ROMCP1 is set to '0', ROM code protect level 1 is turned on, so that the contents of the flash memory are protected against readout and modification.

If either bit of ROMCP2 is set to '0', ROM code protect level 2 is turned on, enabling additional protection against readout and modification (such as by a production LSI tester). If both level 1 and level 2 are enabled, level 2 is selected by default.

If both of the two ROM code protect reset bits are set to "00," ROM code protect is turned off, so that the contents of the flash memory version can be read out or modified. Once ROM code protect is turned on, the contents of the ROM code protect reset bits cannot be modified in parallel I/O mode. Use the serial I/O or some other mode to rewrite the contents of the ROM code protect reset bits.

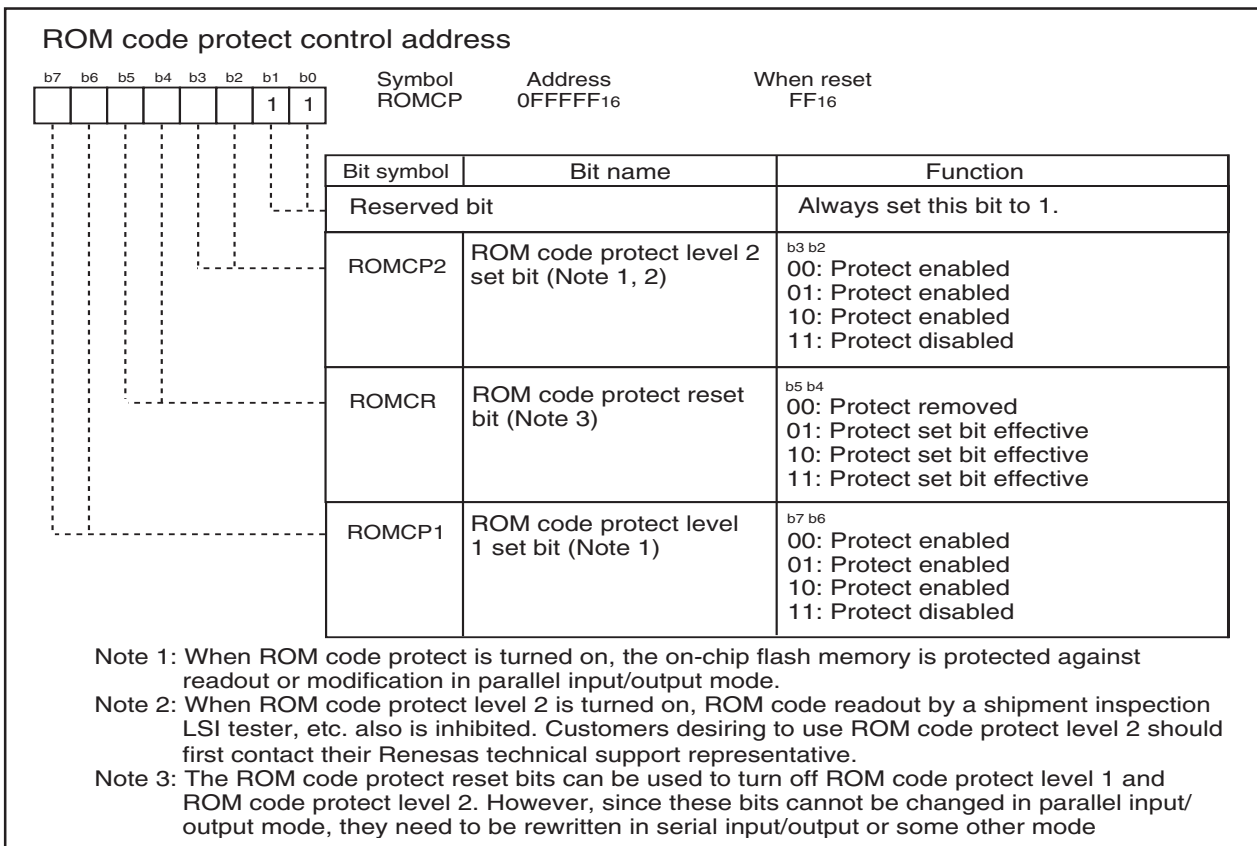

Figure 1.21.1. ROM code protect control address

ID Code Check Function

Use this function in standard serial I/O mode. When the contents of the flash memory are not blank, the ID code sent from the peripheral unit is compared with the ID code written in the flash memory to see if they match. If the ID codes do not match, the commands sent from the peripheral unit are not accepted. The ID code consists of 8-bit data, the areas of which, beginning with the first byte, are 0FFFD₁₆, 0FFFE₃₁₆, 0FFFE_{B16}, 0FFFE_{F16}, 0FFFF₃₁₆, 0FFFF₇₁₆, and 0FFFF_{B16}. Write a program which has had the ID code preset at these addresses to the flash memory.

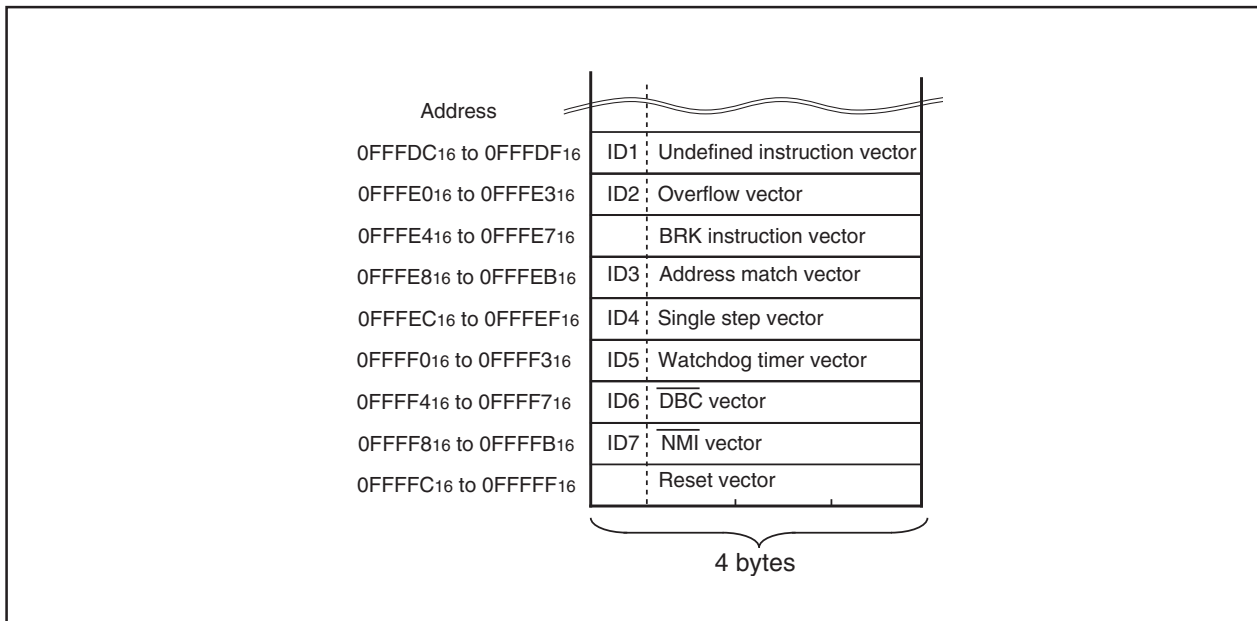

Figure 1.21.2. ID code store addresses

Appendix Standard Serial I/O Mode (Flash Memory Version)

Table 1.22.1. Pin functions (Flash memory standard serial I/O mode)

Pin	Name	I/O	Description
Vcc,Vss	Power input		Apply program/erase protection voltage to Vcc pin and 0 V to Vss pin.
CNVss	CNVss	I	Connect to Vcc pin.
RESET	Reset input	I	Reset input pin. While reset is "L" level, a 20 cycle or longer clock must be input to XIN pin.
XIN	Clock input	I	Connect a ceramic resonator or crystal oscillator between XIN and XOUT pins. To input an externally generated clock, input it to XIN pin and open XOUT pin.
XOUT	Clock output	O	
AVcc, AVss	Analog power supply input	I	Connect AVss to Vss and AVcc to Vcc, respectively
IVCC	Power supply	—	This pin must be left unconnected.
VREF	Reference voltage input	I	Enter the reference voltage for AD from this pin.
P10 to P17	Input port P1	I	Input "H" or "L" level signal or open
P60 to P63	Input port P6	I	Input "H" or "L" level signal or open.
P64	BUSY output	O	Standard serial I/O mode 1: BUSY signal output pin Standard serial I/O mode 2: Monitors the boot program operation check signal output pin.
P65	SCLK input	I	Standard serial I/O mode 1: Serial clock input pin Standard serial I/O mode 2: Input "L".
P66	RxD input	I	Serial data input pin
P67	TxD output	O	Serial data output pin
P70 to P77	Input port P7	I	Input "H" or "L" level signal or open.
P80 to P83, P86, P87	Input port P8	I	Input "H" or "L" level signal or open.
P86	CE input	I	Input "H" level signal.
P90 to P97	Input port P9	I	Input "H" or "L" level signal or open.
P100 to P107	Input port P10	I	Input "H" or "L" level signal or open.

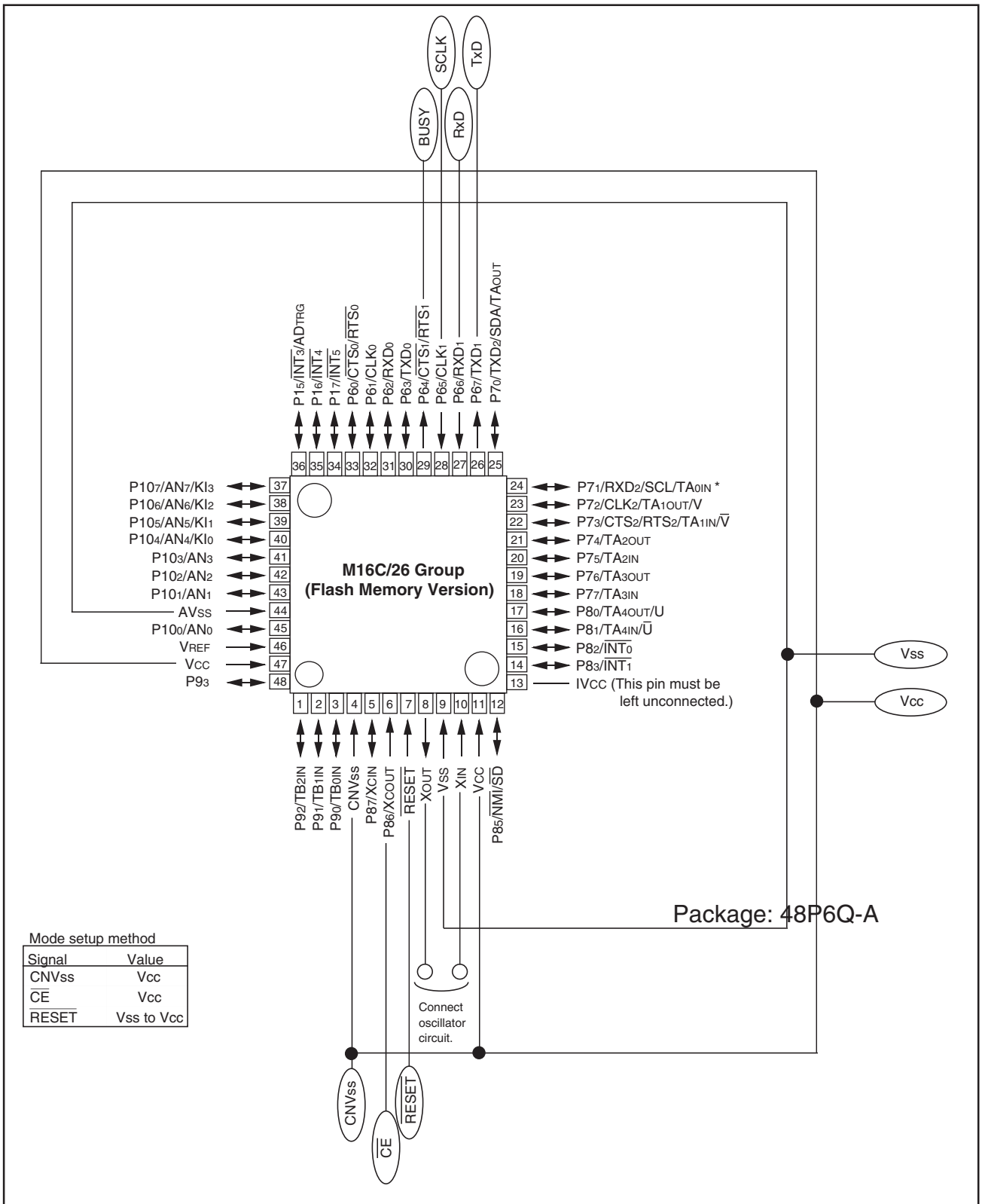

Figure 1.22.1. Pin connections for serial I/O mode (1)

Standard Serial I/O mode

The standard serial I/O mode inputs and outputs the software commands, addresses and data needed to operate (read, program, erase, etc.) the internal flash memory using the serial I/O port UART1. The serial I/O mode transfers the data serially in 8-bit units.

The standard serial I/O mode is different from the parallel I/O mode in that the CPU executes a control program for flash memory rewrite (using the CPU's rewrite mode), rewrite data input and so forth. It is started when both the P86(CE) pin and the CNVss pin are in "H" level after the reset is released. (In normal operation mode, set CNVss pin to "L" level.)

Figure 1.22.1 shows the pin connections for the standard serial I/O mode.

There are actually two standard serial I/O modes: mode 1, which is clock synchronized, and mode 2, which is asynchronous. Standard serial I/O switches between mode 1 (clock synchronous) and mode 2 (clock asynchronous) depending on the level of CLK1 pin when the reset is released.

To use standard serial I/O mode 1 (clock synchronous), set the CLK1 pin to "H" level and release the reset. The operation uses the four UART1 pins CLK1, RxD1, TxD1 and RTS1 (BUSY). The CLK1 pin is the transfer clock input pin through which an external transfer clock is input. The TxD1 pin is for CMOS output. The RTS1 (BUSY) pin outputs an "L" level when ready for reception and an "H" level when reception starts. In mode 1, be sure the TxD1 (P67) pin is at high before reset being deasserted.

To use standard serial I/O mode 2 (clock asynchronous), set the CLK1 pin to "L" level and release the reset. The operation uses the two UART1 pins RxD1 and TxD1.

In the standard serial I/O mode, only the user ROM area indicated in Figure 1.19.1 can be rewritten. In addition, a 7-byte ID code exists to protect the device. When there is data in the flash memory, commands sent from the peripheral unit are not accepted unless the ID code matches.

Appendix Standard Serial I/O Mode 1 (Flash Memory Version)

Overview of standard serial I/O mode 1 (clock synchronous)

In standard serial I/O mode 1, software commands, addresses and data are input and output between the microcomputer and peripheral units (serial programmer, etc.) using 4-wire clock-synchronized serial I/O (UART1). Standard serial I/O mode 1 is entered by releasing the reset with the P65 (CLK1) pin "H" level (and P86 (CE) pin and the CNVss pin are in "H" level).

When receiving software commands, addresses and program data are synchronized with the rising edge of the transfer clock that is input to the CLK1 pin, and are then input to the RXD1 pin. When transmitting, read data and status are synchronized with the falling edge of the transfer clock, and output from the TxD1 pin. The data transfer is in 8-bit units with LSB first.

The TxD1 pin is a CMOS level output.

When the device is busy, such as during transmission, reception, erasing or program execution, the RTS1 (BUSY) pin is "H" level. Accordingly, always start the next transfer after the RTS1 (BUSY) pin is "L" level.

Also, data and status registers in memory can be read after inputting software commands. Status, such as the operating state of the flash memory or whether a program or erase operation ended successfully or not, can be checked by reading the status register. The following table shows the software commands, status registers, etc. in serial I/O mode 1.

Software Commands

Table 1.22.2 lists the software commands, and their descriptions, in standard serial I/O mode 1. Erase operations, programming, reading status, etc. are controlled by transferring software commands via the RxD1 pin.

Table 1.22.2. Software commands (Standard serial I/O mode 1) (Note 1)

	Control Command	1st Byte Transfer	2nd Byte	3rd Byte	4th Byte	5th Byte	6th Byte	... nth Byte	When ID is not verified
1	Page read (Note 2)	FF ₁₆	Address (middle)	Address (high)	Data output	Data output	Data output	Data output to 259th byte	Not acceptable
2	Page program	41 ₁₆	Address (middle)	Address (high)	Data input	Data input	Data input	Data input to 259th byte	Not acceptable
3	Block erase	20 ₁₆	Address (middle)	Address (high)	D0 ₁₆				Not acceptable
4	Erase all code blocks (Note 4)	A7 ₁₆	D0 ₁₆						Not acceptable
5	Read status register (Notes 2,3)	70 ₁₆	SRD output	SRD1 output					Acceptable
6	Clear status register	50 ₁₆							Not acceptable
7	ID check function	F5 ₁₆	Address (low)	Address (middle)	Address (high)	ID size	ID1	To ID7	Acceptable
8	Download function	FA ₁₆	Size (low)	Size (high)	Checksum	Data input	To required no. of times		Not acceptable
9	Version data output function (Note 2)	FB ₁₆	Version data output	Version data output	Version data output	Version data output	Version data output	Version data output to 9th byte	Acceptable
10	Read check data (Note 2)	FD ₁₆	Check data (low)	Check data (high)					Not acceptable

Note 1: All commands can be accepted when the flash memory is totally blank.

Note 2: Shaded area indicates transfer from flash memory microcomputer to peripheral unit. All other data is transferred from the peripheral unit to the flash memory microcomputer.

Note 3: SRD refers to status register data. SRD1 refers to status register 1 data.

Note 4: The 'erase all' command does not erase the Flash data blocks.

Page Read Command

This command reads the specified page (256 bytes) in the flash memory sequentially one byte at a time. Execute the page read command as explained here following.

- (1) Transfer the "FF₁₆" command code with the 1st byte.
- (2) Transfer addresses A₈ to A₁₅ and A₁₆ to A₂₃ with the 2nd and 3rd bytes respectively.
- (3) From the 4th byte onward, data (D₀–D₇) for the page (256 bytes) specified with addresses A₈ to A₂₃ will be output sequentially from the smallest address first in sync with the fall of the clock.

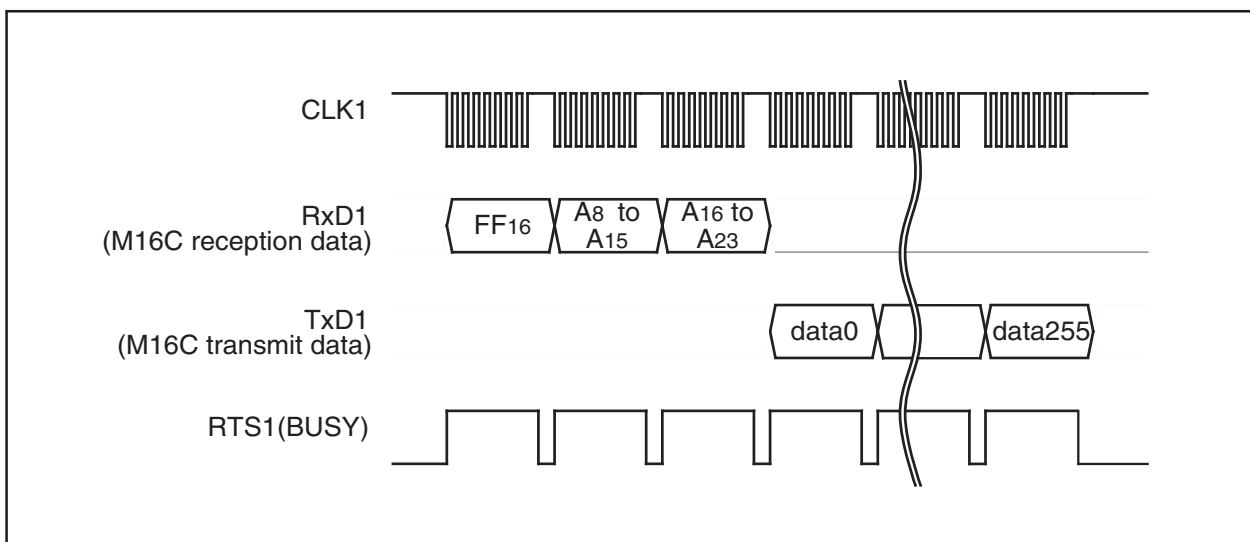

Figure 1.22.2. Timing for page read

Read Status Register Command

This command reads status information. When the "70₁₆" command code is sent with the 1st byte, the contents of the status register (SRD) specified with the 2nd byte and the contents of status register 1 (SRD1) specified with the 3rd byte are read.

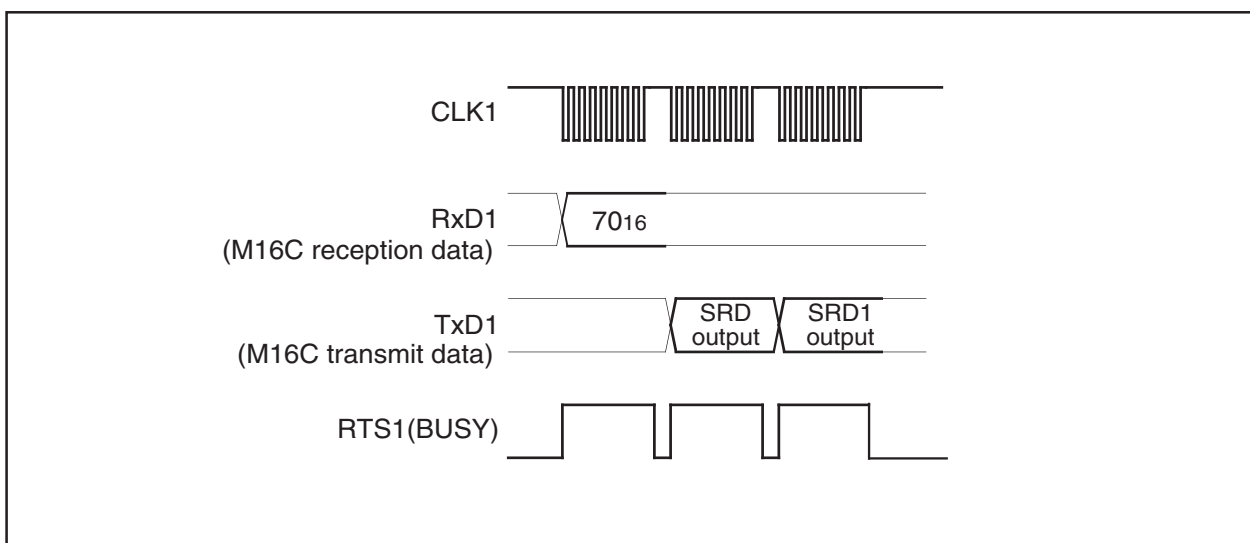

Figure 1.22.3. Timing for reading the status register

Clear Status Register Command

This command clears the bits (SR4, SR5) which are set when the status register operation ends in error. When the “5016” command code is sent with the 1st byte, the aforementioned bits are cleared. When the clear status register operation ends, the RTS1 (BUSY) signal changes from the “H” to the “L” level.

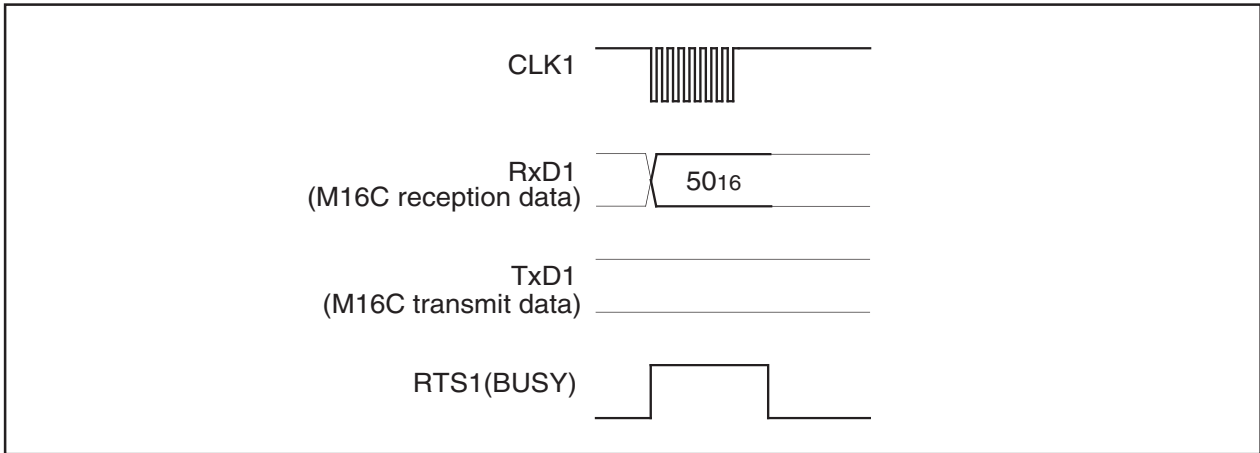

Figure 1.22.4. Timing for clearing the status register

Page Program Command

This command writes the specified page (256 bytes) in the flash memory sequentially one byte at a time. Execute the page program command as explained here following.

- (1) Transfer the “4116” command code with the 1st byte.
- (2) Transfer addresses A8 to A15 and A16 to A23 with the 2nd and 3rd bytes respectively.
- (3) From the 4th byte onward, as write data (D0–D7) for the page (256 bytes) specified with addresses A8 to A23 is input sequentially from the smallest address first, that page is automatically written.

When reception setup for the next 256 bytes ends, the RTS1 (BUSY) signal changes from the “H” to the “L” level. The result of the page program can be known by reading the status register. For more information, see the section on the status register.

Each block can be write-protected with the lock bit. For more information, see the section on the data protection function. Additional writing is not allowed with already programmed pages.

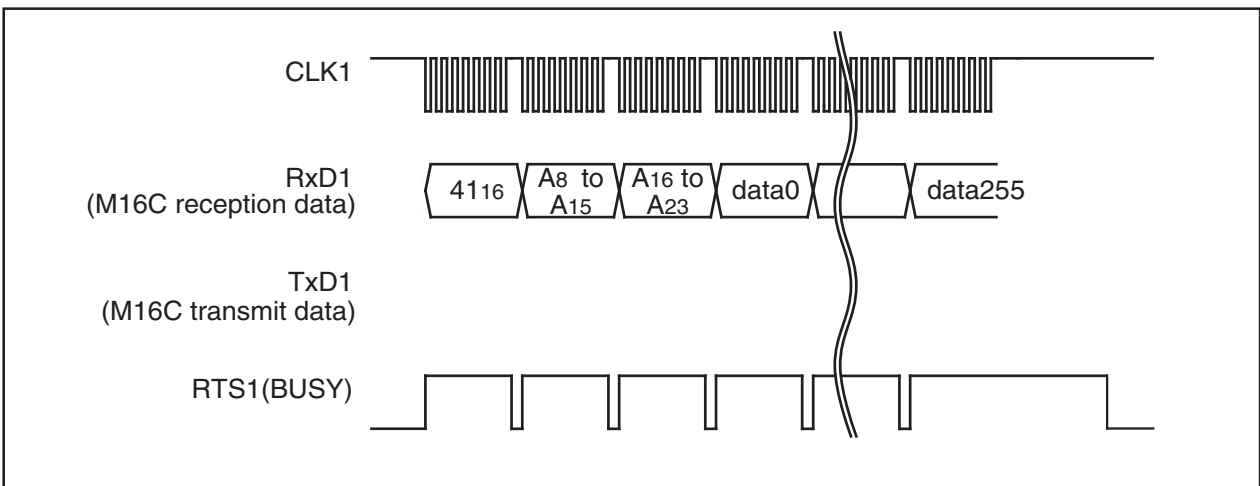

Figure 1.22.5. Timing for the page program

Block Erase Command

This command erases the data in the specified block. Execute the block erase command as explained here following.

- (1) Transfer the "20₁₆" command code with the 1st byte.
- (2) Transfer addresses A₈ to A₁₅ and A₁₆ to A₂₃ with the 2nd and 3rd bytes respectively.
- (3) Transfer the verify command code "D0₁₆" with the 4th byte. With the verify command code, the erase operation will start for the specified block in the flash memory. Write the highest address of the specified block for addresses A₈ to A₂₃.

When block erasing ends, the RTS₁ (BUSY) signal changes from the "H" to the "L" level. After block erase ends, the result of the block erase operation can be known by reading the status register. For more information, see the section on the status register.

Each block can be erase-protected with the lock bit. For more information, see the section on the data protection function.

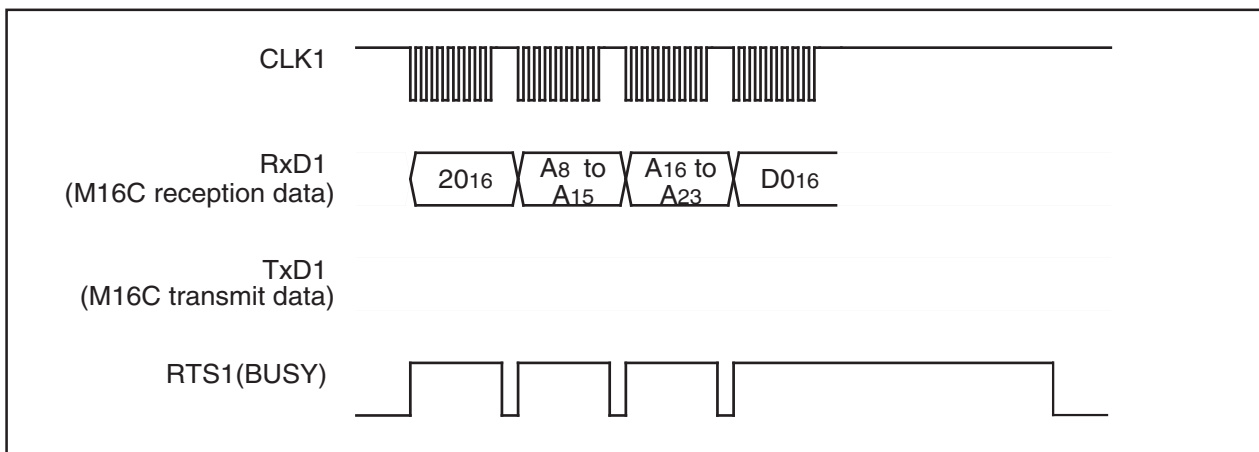

Figure 1.22.6. Timing for block erasing

Erase All Code Blocks Command

This command erases the content of all code blocks. Execute the erase all code blocks command as explained here following.

- (1) Transfer the "A7₁₆" command code with the 1st byte.
- (2) Transfer the verify command code "D0₁₆" with the 2nd byte. With the verify command code, the erase operation will start and continue for all code blocks in the flash memory.

When block erasing ends, the RTS₁ (BUSY) signal changes from the "H" to the "L" level. The result of the erase operation can be known by reading the status register.

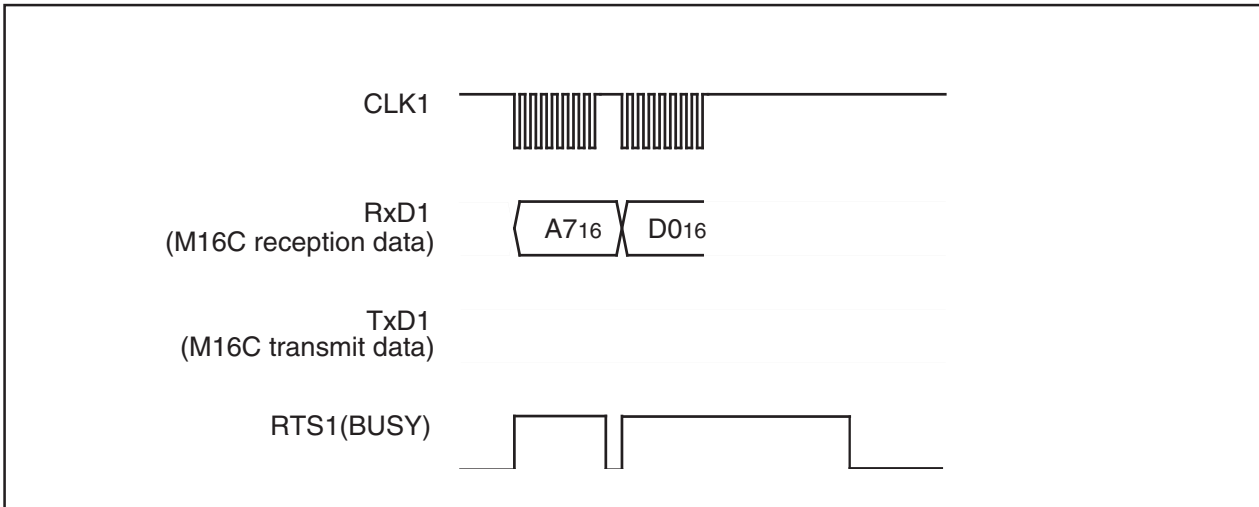

Figure 1.22.7. Timing for erasing all code blocks.

Download Command

This command downloads a program to the RAM for execution. Execute the download command as explained here following.

- (1) Transfer the "FA16" command code with the 1st byte.
- (2) Transfer the program size with the 2nd and 3rd bytes.
- (3) Transfer the check sum with the 4th byte. The check sum is added to all data sent with the 5th byte onward.
- (4) The program to execute is sent with the 5th byte onward.

When all data has been transmitted, if the check sum matches, the downloaded program is executed. The size of the program will vary according to the internal RAM.

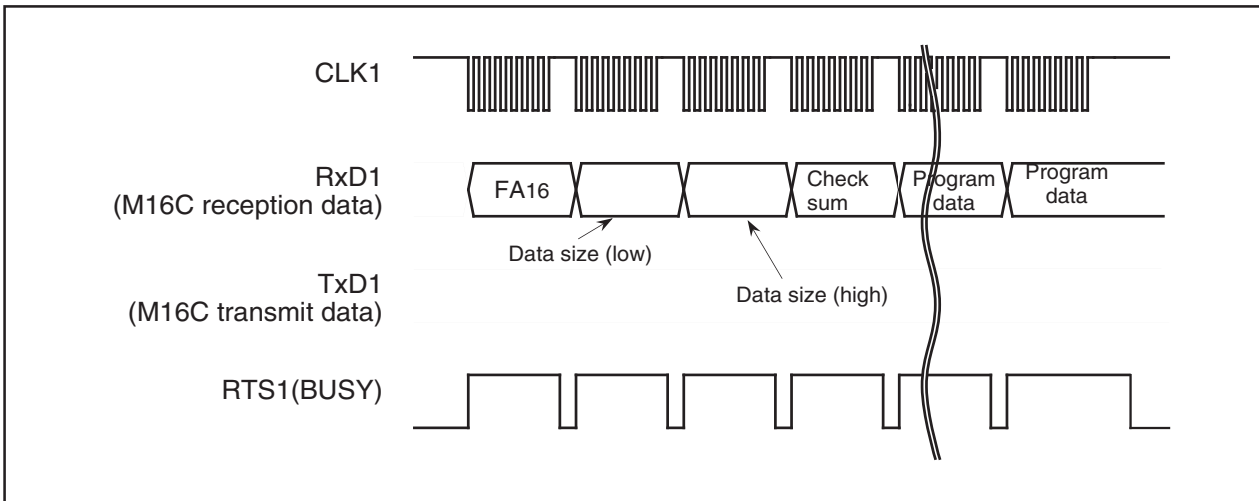

Figure 1.22.8. Timing for download

Version Information Output Command

This command outputs the version information of the control program. Execute the version information output command as explained here following.

- (1) Transfer the "FB16" command code with the 1st byte.
- (2) The version information will be output from the 2nd byte onward. This data is composed of 8 ASCII code characters.

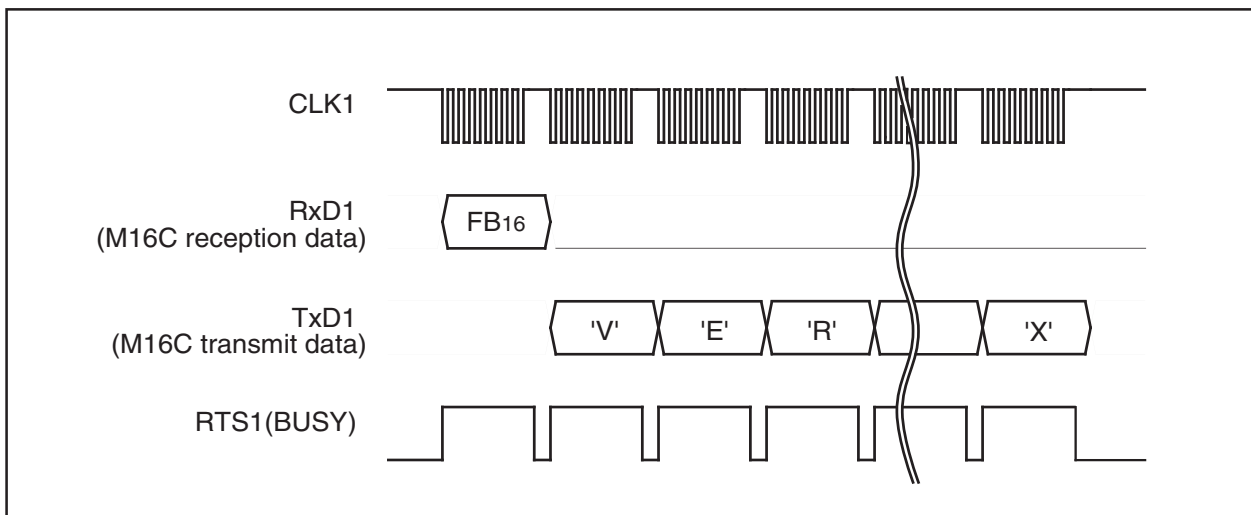

Figure 1.22.9. Timing for version information output

ID Check

This command checks the ID code. Execute the boot ID check command as explained here following.

- (1) Transfer the "F5₁₆" command code with the 1st byte.
- (2) Transfer addresses A₀ to A₇, A₈ to A₁₅ and A₁₆ to A₂₃ of the 1st byte of the ID code with the 2nd, 3rd and 4th bytes respectively.
- (3) Transfer the number of data sets of the ID code with the 5th byte.
- (4) The ID code is sent with the 6th byte onward, starting with the 1st byte of the code.

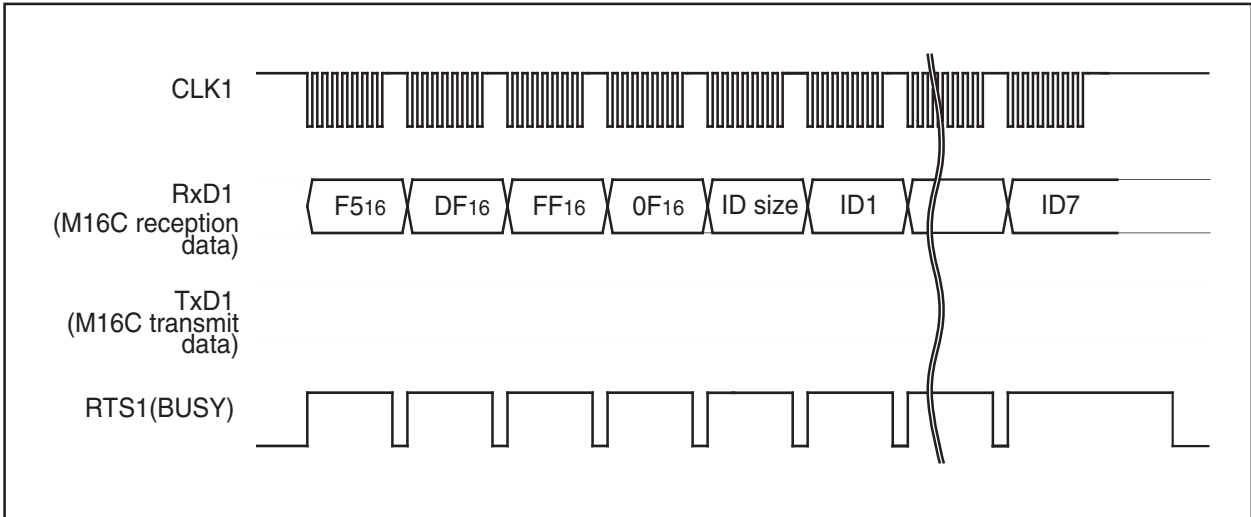

Figure 1.22.10. Timing for the ID check

ID Code

When the flash memory is not blank, the ID code sent from the peripheral units and the ID code written in the flash memory are compared to see if they match. If the codes do not match, the command sent from the peripheral units is not accepted. An ID code contains 8 bits of data. Area is, from the 1st byte, addresses 0FFFD₁₆, 0FFFE₃₁₆, 0FFFE_{B16}, 0FFFE_{F16}, 0FFFF₃₁₆, 0FFFF₇₁₆ and 0FFFF_{B16}. Write a program into the flash memory, which already has the ID code set for these addresses.

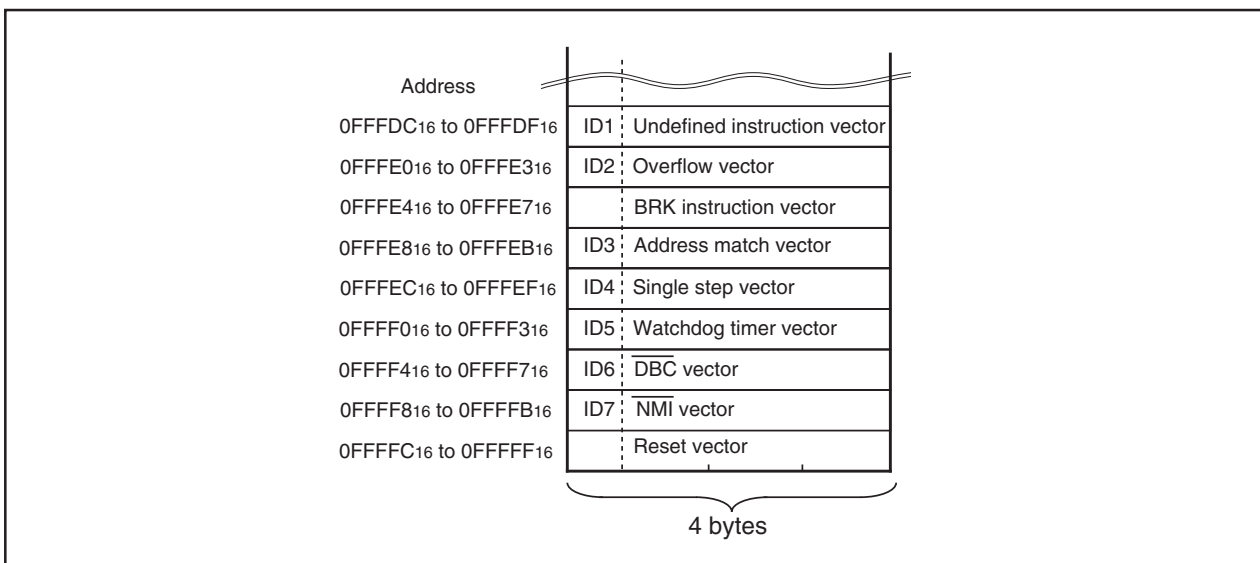

Figure 1.22.11. ID code storage addresses

Read Check Data

This command reads the check data that confirms that the write data, which was sent with the page program command, was successfully received.

- (1) Transfer the "FD16" command code with the 1st byte.
- (2) The check data (low) is received with the 2nd byte and the check data (high) with the 3rd.

To use this read check data command, first execute the command and then initialize the check data. Next, execute the page program command the required number of times. After that, when the read check command is executed again, the check data for all of the read data that was sent with the page program command during this time is read. The check data is the result of CRC operation of write data.

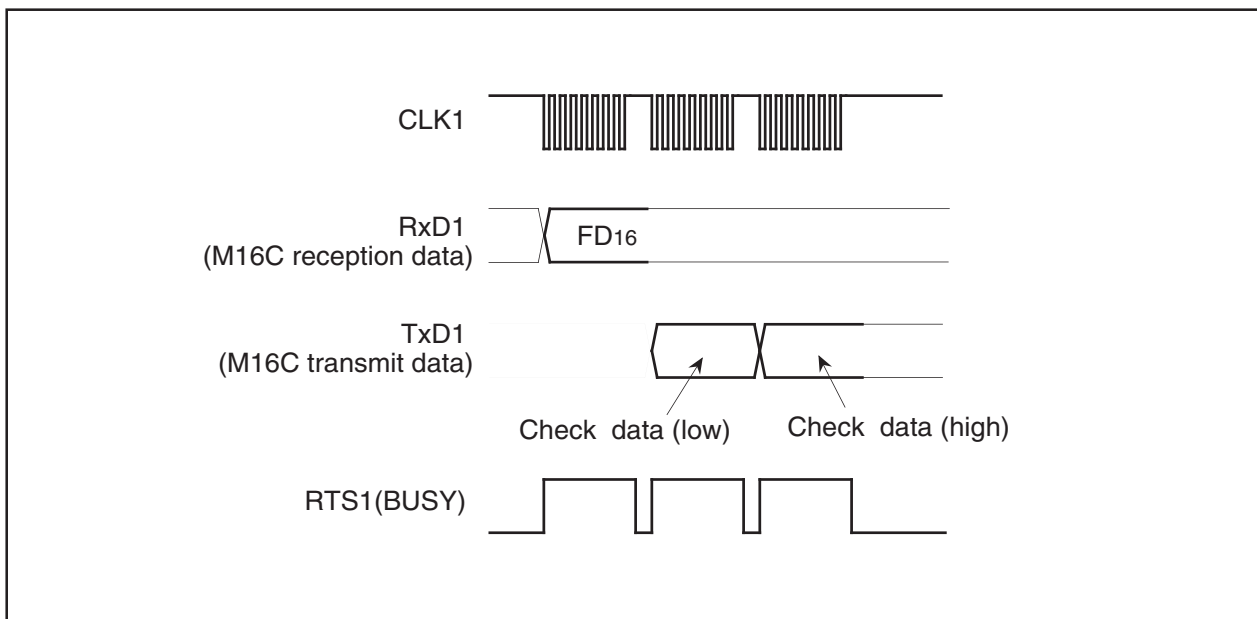

Figure 1.22.12. Timing for the read check data

Status Register (SRD)

The status register indicates operating status of the flash memory and status such as whether an erase operation or a program ended successfully or in error. It can be read by writing the read status register command (70₁₆). Also, the status register is cleared by writing the clear status register command (50₁₆). Table 1.22.3 gives the definition of each status register bit. After clearing the reset, the status register outputs "80₁₆".

Table 1.22.3. Status register (SRD)

SRD0 bits	Status name	Definition	
		"1"	"0"
SR7 (bit7)	Sequencer status	Ready	Busy
SR6 (bit6)	Reserved	-	-
SR5 (bit5)	Erase status	Terminated in error	Terminated normally
SR4 (bit4)	Program status	Terminated in error	Terminated normally
SR3 (bit3)	Reserved	-	-
SR2 (bit2)	Reserved	-	-
SR1 (bit1)	Reserved	-	-
SR0 (bit0)	Reserved	-	-

Sequencer status (SR7)

After power-on, the sequencer status is set to 1 (ready).

The sequencer status indicates the operating status of the device. This status bit is set to "0" (busy) during write or erase operation and is set to 1 upon completion of these operations.

Erase Status (SR5)

The erase status reports the operating status of the auto erase operation. If an erase error occurs, it is set to "1". When the erase status is cleared, it is set to "0".

Program Status (SR4)

The program status reports the operating status of the auto write operation. If a write error occurs, it is set to "1". When the program status is cleared, it is set to "0".

Status Register 1 (SRD1)

Status register 1 indicates the status of serial communications, results from ID checks and results from check sum comparisons. It can be read after the SRD by writing the read status register command (7016). Also, status register 1 is cleared by writing the clear status register command (5016).

Table 1.22.4 gives the definition of each status register 1 bit. "0016" is output when power is turned ON and the flag status is maintained even after the reset.

Table 1.22.4. Status register 1 (SRD1)

SRD1 bits	Status name	Definition	
		"1"	"0"
SR15 (bit7)	Boot update completed bit	Update completed	Not update
SR14 (bit6)	Flash identification value	HND	DINOR
SR13 (bit5)	Reserved	-	-
SR12 (bit4)	Check sum match bit	Match	Mismatch
SR11 (bit3) SR10 (bit2)	ID check completed bits	00 01 10 11	Not verified Verification mismatch Reserved Verified
SR9 (bit1)	Data receive time out	Time out	Normal operation
SR8 (bit0)	Reserved	-	-

Boot Update Completed Bit (SR15)

This flag indicates whether the control program was downloaded to the RAM or not, using the download function.

Flash Identification Value (SR14)

This flag indicates whether the flash memor type is HND or DINOR.

Check Sum Match Bit (SR12)

This flag indicates whether the check sum matches or not when a program, is downloaded for execution using the download function.

ID Check Completed Bits (SR11 and SR10)

These flags indicate the result of ID checks. Some commands cannot be accepted without an ID check.

Data Receive Time Out (SR9)

This flag indicates when a time out error is generated during data reception. If this flag is attached during data reception, the received data is discarded and the microcomputer returns to the command wait state.

Full Status Check

Results from executed erase and program operations can be known by running a full status check. Figure 1.22.13 shows a flowchart of the full status check and explains how to remedy errors which occur.

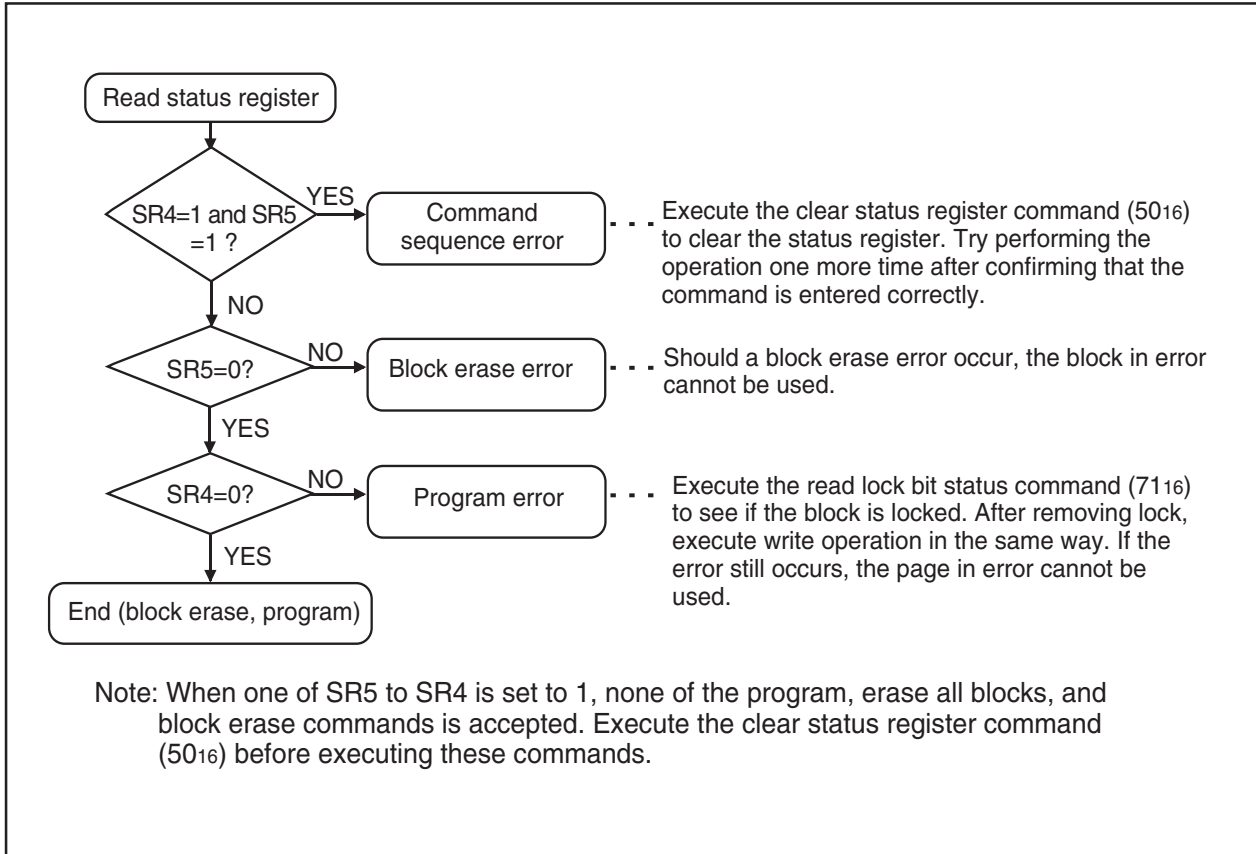

Figure 1.22.13. Full status check flowchart and remedial procedure for errors

Example Circuit Application for The Standard Serial I/O Mode 1

The below figure shows a circuit application for the standard serial I/O mode 1. Control pins will vary according to programmer, therefore see the peripheral unit manual for more information.

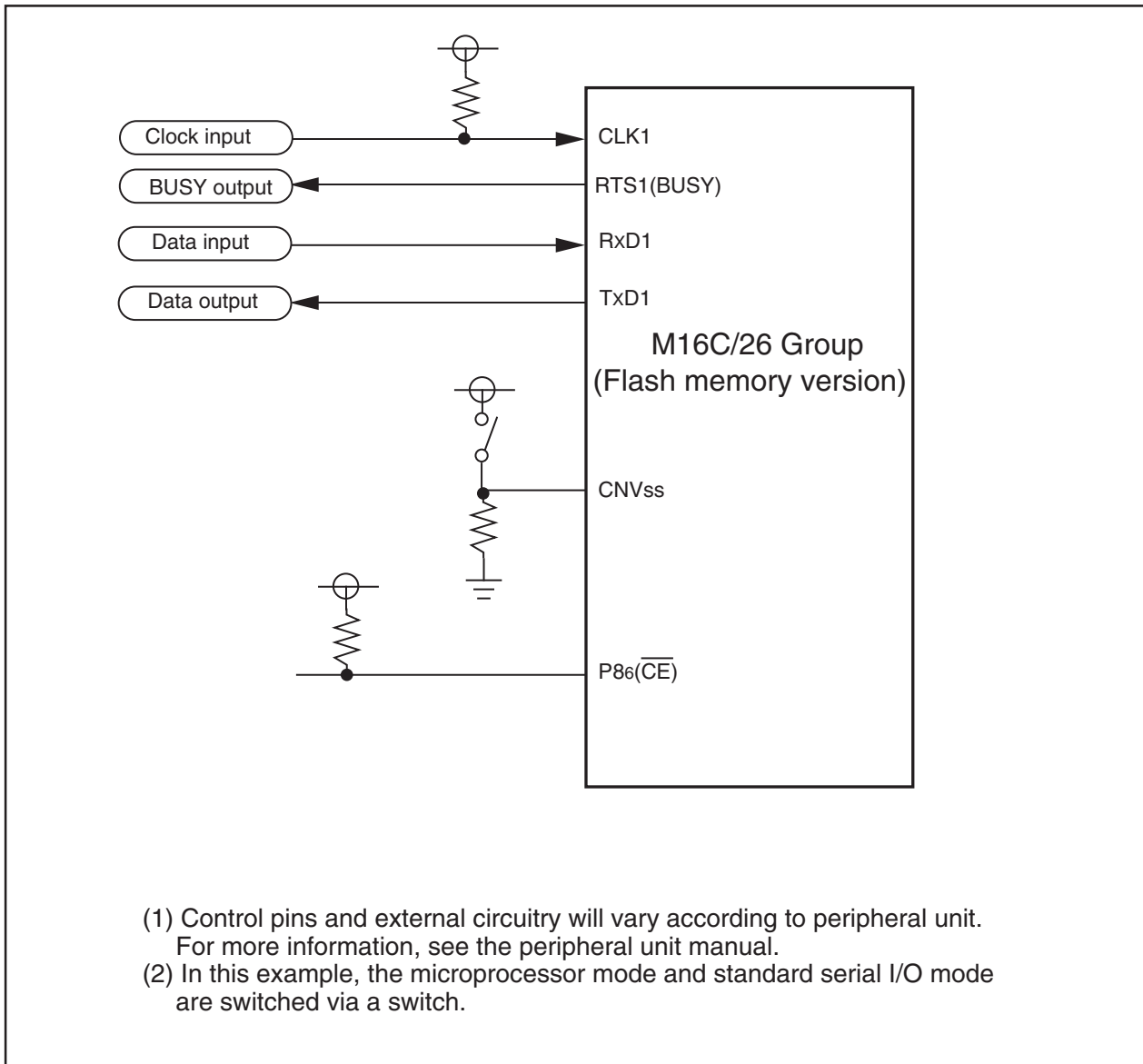

Figure 1.22.14. Example circuit application for the standard serial I/O mode 1

Appendix Standard Serial I/O Mode 2 (Flash Memory Version)

Overview of standard serial I/O mode 2 (clock asynchronous)

In standard serial I/O mode 2, software commands, addresses and data are input and output between the microcomputer and peripheral units (serial programmer, etc.) using 2-wire clock-asynchronized serial I/O (UART1). Standard serial I/O mode 2 is engaged by releasing the reset with the P65 (CLK1) pin "L" level and P86 (CE) pin and the CNVss pin are in "H" level).

The TxD1 pin is for CMOS output. Data transfer is in 8-bit units with LSB first, 1 stop bit and parity OFF.

After the reset is released, connections can be established at 9,600 bps when initial communications (Figure 1.23.1) are made with a peripheral unit that requires a main clock with a minimum 2 MHz input oscillation frequency. Baud rate can also be changed from 9,600 bps to 19,200, 38,400 or 57,600 bps by executing software commands. However, if communication errors due to the oscillation frequency of the main clock, change the main clock's oscillation frequency and the baud rate.

After executing commands from a peripheral unit that requires time, i.e. erase, or write (program) data, allow sufficient time to pass or execute the read status command to check the device status, before executing the next command.

Data and status registers in memory can be read after transmitting software commands. Status, such as the operating state of the flash memory or whether a program or erase operation ended successfully or not, can be checked by reading the status register. The following describes the initial communications with peripheral units, how frequency is identified, and software commands.

Initial communications with peripheral units

After the reset is released, the bit rate generator is adjusted to 9,600 bps to match the oscillation frequency of the main clock, by sending the code as prescribed by the protocol for initial communications with peripheral units (Figure 1.23.1).

- (1) Transmit "B016" from a peripheral unit. If the oscillation frequency input by the main clock is 10 or 16 MHz, the microcomputer with internal flash memory outputs the "B016" check code. If the oscillation frequency is anything other than 10 or 16 MHz, the microcomputer does not output anything.
- (2) Transmit "0016" from a peripheral unit 16 times. (The microcomputer with internal flash memory sets the bit rate generator so that "0016" can be successfully received.)
- (3) The microcomputer with internal flash memory outputs the "B016" check code and initial communications end successfully *1. Initial communications must be transmitted at a speed of 9,600 bps and a transfer interval of a minimum 15 ms. Also, the baud rate at the end of initial communications is 9,600 bps.

*1. If the peripheral unit cannot receive "B016" successfully, change the oscillation frequency of the main clock.

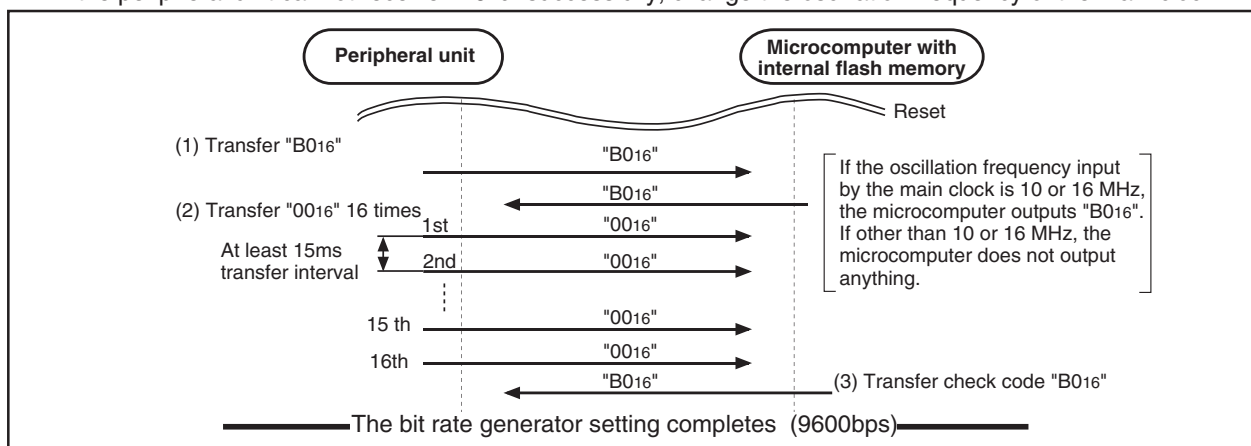

Figure 1.23.1. Peripheral unit and initial communication

How frequency is identified

When "0016" data is received 16 times from a peripheral unit at a baud rate of 9,600 bps, the value of the bit rate generator is set to match the operating frequency (2 - 20 MHz). The highest speed is taken from the first 8 transmissions and the lowest from the last 8. These values are then used to calculate the bit rate generator value for a baud rate of 9,600 bps.

Baud rate cannot be attained with some operating frequencies. Table 1.23.1 gives the operation frequency and the baud rate that can be attained for.

Table 1.23.1 Operation frequency and the baud rate

Operation frequency (MHz)	Baud rate 9,600bps	Baud rate 19,200bps	Baud rate 38,400bps	Baud rate 57,600bps
20MHz	☑	☑	☑	☑
16MHz	☑	☑	☑	☑
12MHz	☑	☑	☑	-
11MHz	☑	☑	☑	-
10MHz	☑	☑	-	☑
8MHz	☑	☑	-	☑
7.3728MHz	☑	☑	☑	
6MHz	☑	☑	☑	-
5MHz	☑	☑	-	-
4.5MHz	☑	☑	-	☑
4.194304MHz	☑	☑	☑	-
4MHz	☑	☑	-	-
3.58MHz	☑	☑	☑	☑
3MHz	☑	☑	☑	-
2MHz	☑	-	-	-

☑: Communications possible
- : Communications not possible

Software Commands

Table 1.23.2 lists software commands. In the standard serial I/O mode 2, erase operations, programs and reading are controlled by transferring software commands via the RxD₁ pin. Standard serial I/O mode 2 adds four transmission speed commands - 9,600, 19,200, 38,400 and 57,600 bps - to the software commands of standard serial I/O mode 1. Software commands are explained here below.

Table 1.23.2. Software commands (Standard serial I/O mode 2) (Note 1)

	Control Command	1st Byte Transfer	2nd Byte	3rd Byte	4th Byte	5th Byte	6th Byte	... nth Byte	When ID is not verified
1	Page read (Note 2)	FF ₁₆	Address (middle)	Address (high)	Data output	Data output	Data output	Data output to 259th byte	Not acceptable
2	Page program	41 ₁₆	Address (middle)	Address (high)	Data input	Data input	Data input	Data input to 259th byte	Not acceptable
3	Block erase	20 ₁₆	Address (middle)	Address (high)	D0 ₁₆				Not acceptable
4	Erase all code blocks (Note 4)	A7 ₁₆	D0 ₁₆						Not acceptable
5	Read status register (Notes 2,3)	70 ₁₆	SRD output	SRD1 output					Acceptable
6	Clear status register	50 ₁₆							Not acceptable
7	ID check function	F5 ₁₆	Address (low)	Address (middle)	Address (high)	ID size	ID1	To ID7	Acceptable
8	Download function	FA ₁₆	Size (low)	Size (high)	Checksum	Data input	To required no. of times		Not acceptable
9	Version data output function (Note 2)	FB ₁₆	Version data output	Version data output	Version data output	Version data output	Version data output	Version data output to 9th byte	Acceptable
10	Read check data (Note 2)	FD ₁₆	Check data (low)	Check data (high)					Not acceptable
11	Baud rate 9600 (Note 2)	B0 ₁₆	B0 ₁₆						Acceptable
12	Baud rate 19200 (Note 2)	B1 ₁₆	B1 ₁₆						Acceptable
13	Baud rate 38400 (Note 2)	B2 ₁₆	B2 ₁₆						Acceptable
14	Baud rate 57600 (Note 2)	B3 ₁₆	B3 ₁₆						Acceptable

Note 1: All commands can be accepted when the flash memory is totally blank.

Note 2: Shading indicates transfer from flash memory microcomputer to peripheral unit. All other data is transferred from the peripheral unit to the flash memory microcomputer.

Note 3: SRD refers to status register data. SRD1 refers to status register 1 data.

Note 4: The 'erase all' command does not erase the Flash data blocks.

Page Read Command

This command reads the specified page (256 bytes) in the flash memory sequentially one byte at a time. Execute the page read command as explained here following.

- (1) Transfer the "FF₁₆" command code with the 1st byte.
- (2) Transfer addresses A₈ to A₁₅ and A₁₆ to A₂₃ with the 2nd and 3rd bytes respectively.
- (3) From the 4th byte onward, data (D₀–D₇) for the page (256 bytes) specified with addresses A₈ to A₂₃ will be output sequentially from the smallest address first.

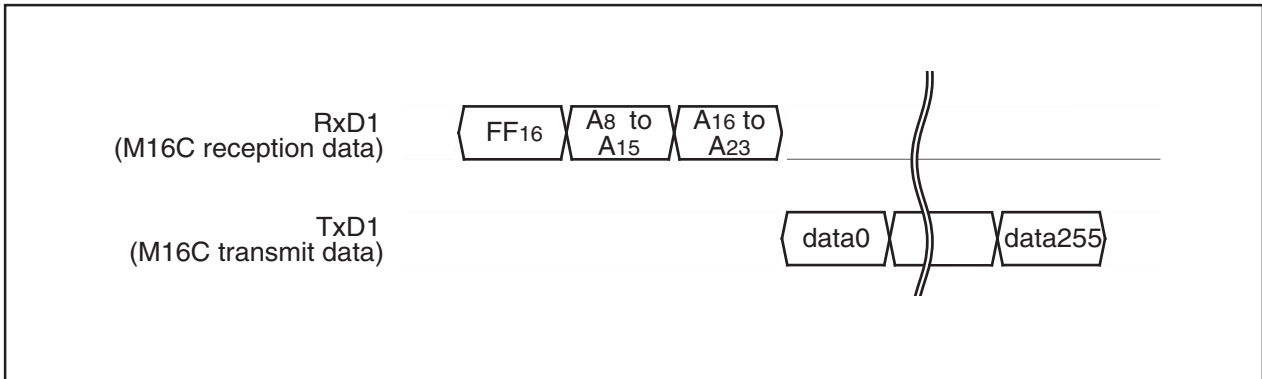

Figure 1.23.2. Timing for page read

Read Status Register Command

This command reads status information. When the "70₁₆" command code is sent with the 1st byte, the contents of the status register (SRD) specified with the 2nd byte and the contents of status register 1 (SRD1) specified with the 3rd byte are read.

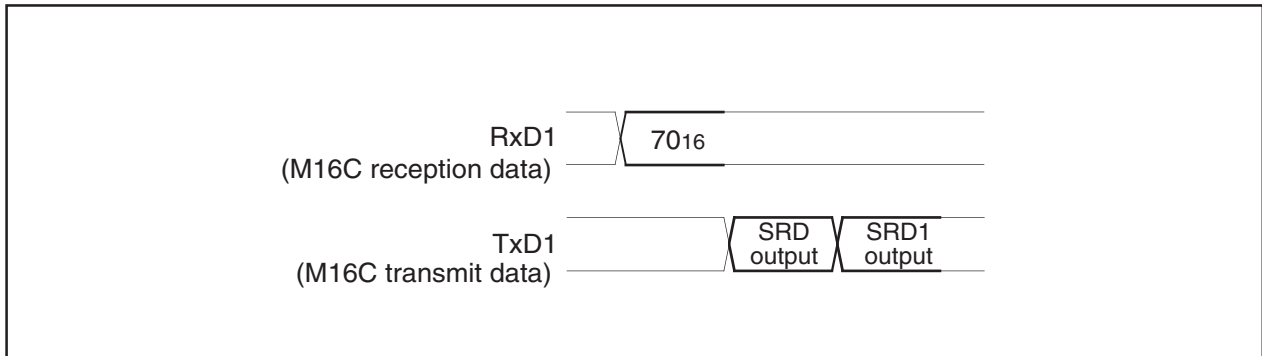

Figure 1.23.3. Timing for reading the status register

Clear Status Register Command

This command clears the bits (SR4, SR5) which are set when the status register operation ends in error. When the “5016” command code is sent with the 1st byte, the aforementioned bits are cleared.

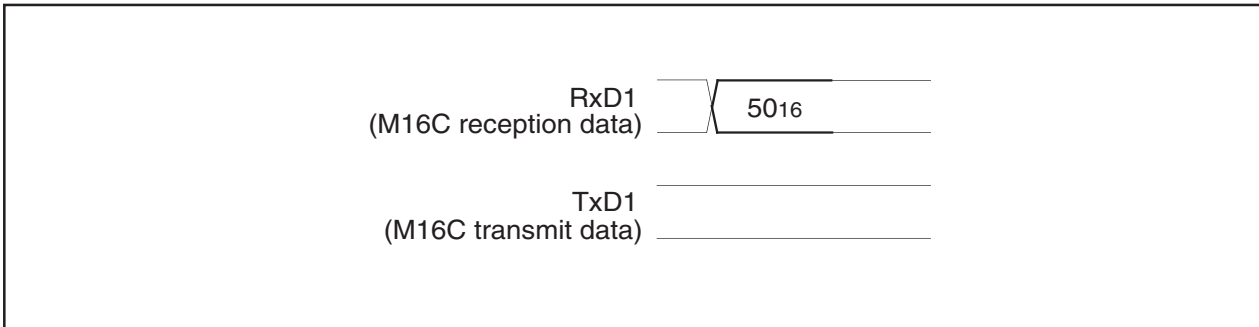

Figure 1.23.4. Timing for clearing the status register

Page Program Command

This command writes the specified page (256 bytes) in the flash memory sequentially one byte at a time. Execute the page program command as explained here following.

- (1) Transfer the “4116” command code with the 1st byte.
- (2) Transfer addresses A8 to A15 and A16 to A23 with the 2nd and 3rd bytes respectively.
- (3) From the 4th byte onward, as write data (D0–D7) for the page (256 bytes) specified with addresses A8 to A23 is input sequentially from the smallest address first, that page is automatically written.

The result of the page program can be known by reading the status register. For more information, see the section on the status register.

Each block can be write-protected with the lock bit. For more information, see the section on the data protection function. Additional writing is not allowed with already programmed pages.

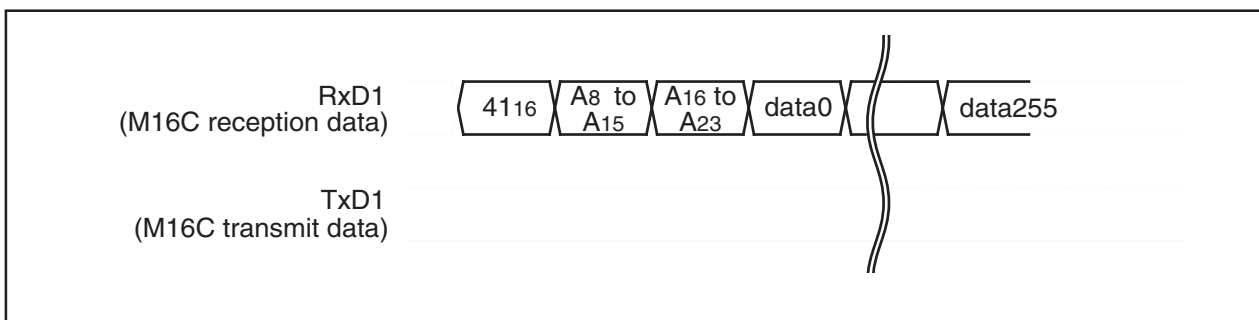

Figure 1.23.5. Timing for the page program

Block Erase Command

This command erases the data in the specified block. Execute the block erase command as explained here following.

- (1) Transfer the “20₁₆” command code with the 1st byte.
- (2) Transfer addresses A₈ to A₁₅ and A₁₆ to A₂₃ with the 2nd and 3rd bytes respectively.
- (3) Transfer the verify command code “D0₁₆” with the 4th byte. With the verify command code, the erase operation will start for the specified block in the flash memory. Write the highest address of the specified block for addresses A₈ to A₂₃.

After block erase ends, the result of the block erase operation can be known by reading the status register. For more information, see the section on the status register.

Each block can be erase-protected with the lock bit. For more information, see the section on the data protection function.

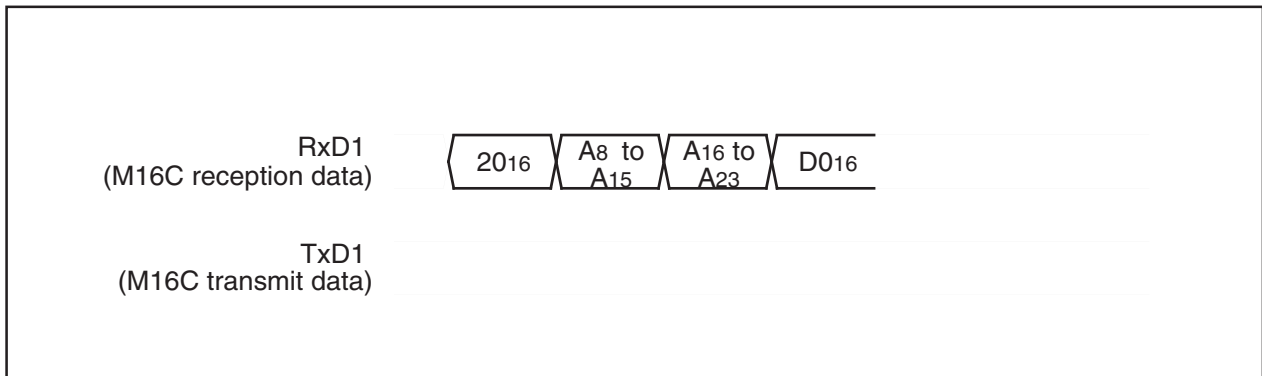

Figure 1.23.6. Timing for block erasing

Erase All Code Blocks Command

This command erases the content of all code blocks. Execute the erase all code blocks command as explained here following.

- (1) Transfer the “A7₁₆” command code with the 1st byte.
- (2) Transfer the verify command code “D0₁₆” with the 2nd byte. With the verify command code, the erase operation will start and continue for all code blocks in the flash memory.

The result of the erase operation can be known by reading the status register.

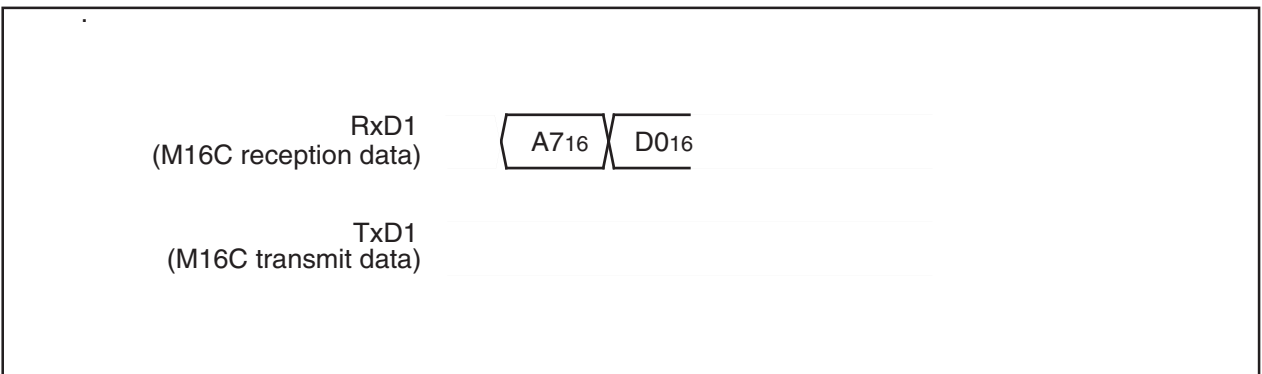

Figure 1.23.7. Timing for erasing all code blocks.

Download Command

This command downloads a program to the RAM for execution. Execute the download command as explained here following.

- (1) Transfer the "FA16" command code with the 1st byte.
- (2) Transfer the program size with the 2nd and 3rd bytes.
- (3) Transfer the check sum with the 4th byte. The check sum is added to all data sent with the 5th byte onward.
- (4) The program to execute is sent with the 5th byte onward.

When all data has been transmitted, if the check sum matches, the downloaded program is executed. The size of the program will vary according to the internal RAM.

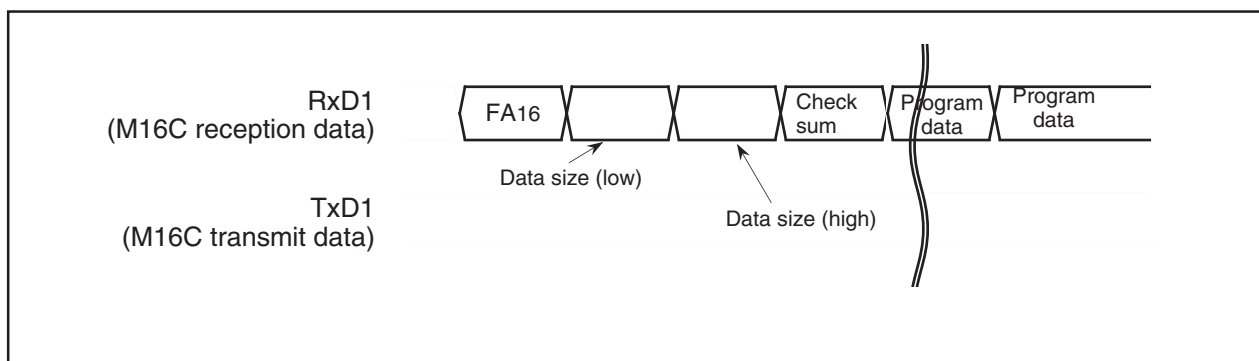

Figure 1.23.8. Timing for download

Version Information Output Command

This command outputs the version information of the control program. Execute the version information output command as explained here following.

- (1) Transfer the "FB16" command code with the 1st byte.
- (2) The version information will be output from the 2nd byte onward. This data is composed of 8 ASCII code characters.

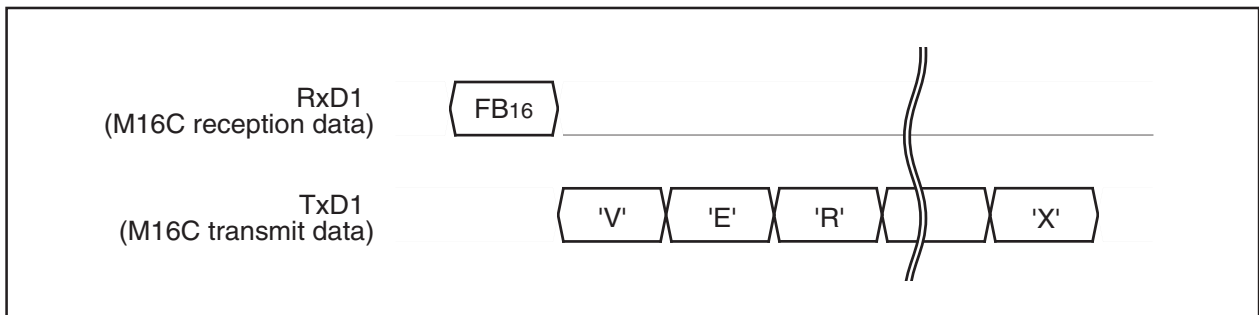

Figure 1.23.9. Timing for version information output

ID Check

This command checks the ID code. Execute the boot ID check command as explained here following.

- (1) Transfer the "F5₁₆" command code with the 1st byte.
- (2) Transfer addresses A₀ to A₇, A₈ to A₁₅ and A₁₆ to A₂₃ of the 1st byte of the ID code with the 2nd, 3rd and 4th bytes respectively.
- (3) Transfer the number of data sets of the ID code with the 5th byte.
- (4) The ID code is sent with the 6th byte onward, starting with the 1st byte of the code.

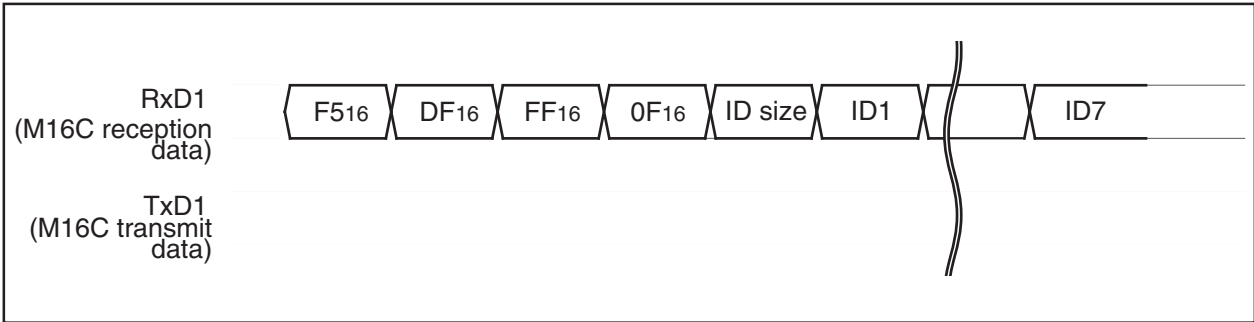

Figure 1.23.10. Timing for the ID check

ID Code

When the flash memory is not blank, the ID code sent from the peripheral units and the ID code written in the flash memory are compared to see if they match. If the codes do not match, the command sent from the peripheral units is not accepted. An ID code contains 8 bits of data. Area is, from the 1st byte, addresses 0FFFDF₁₆, 0FFFE3₁₆, 0FFFEb₁₆, 0FFFEf₁₆, 0FFFF3₁₆, 0FFFF7₁₆ and 0FFFFB₁₆. Write a program into the flash memory, which already has the ID code set for these addresses.

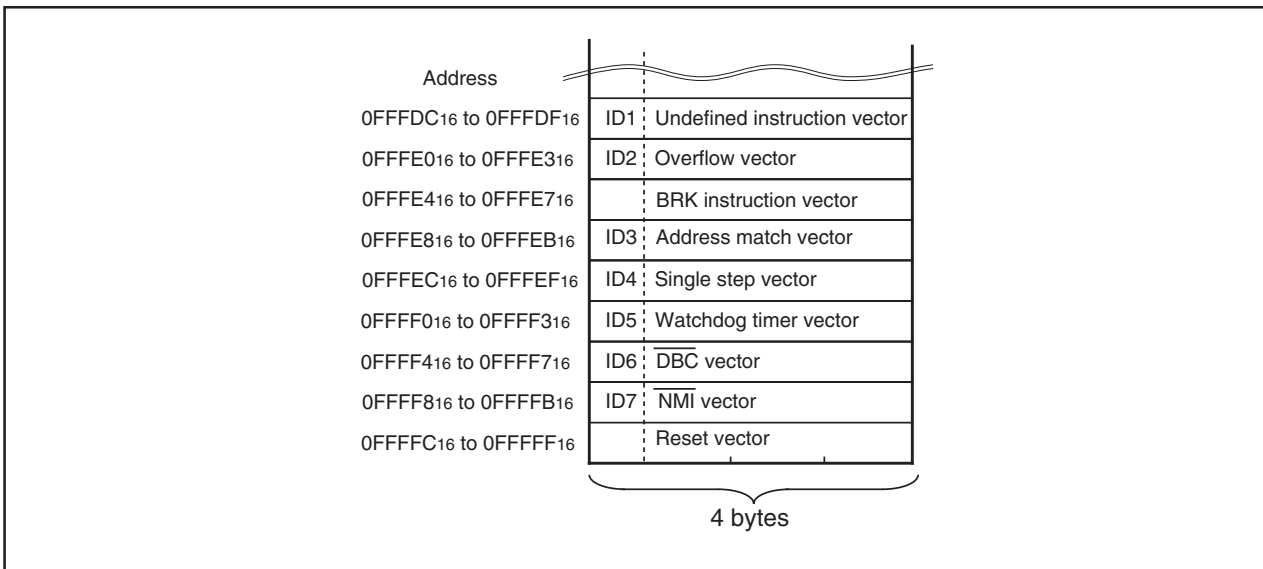

Figure 1.23.11. ID code storage addresses

Read Check Data

This command reads the check data that confirms that the write data, which was sent with the page program command, was successfully received.

- (1) Transfer the "FD16" command code with the 1st byte.
- (2) The check data (low) is received with the 2nd byte and the check data (high) with the 3rd.

To use this read check data command, first execute the command and then initialize the check data. Next, execute the page program command the required number of times. After that, when the read check command is executed again, the check data for all of the read data that was sent with the page program command during this time is read. The check data is the result of CRC operation of write data.

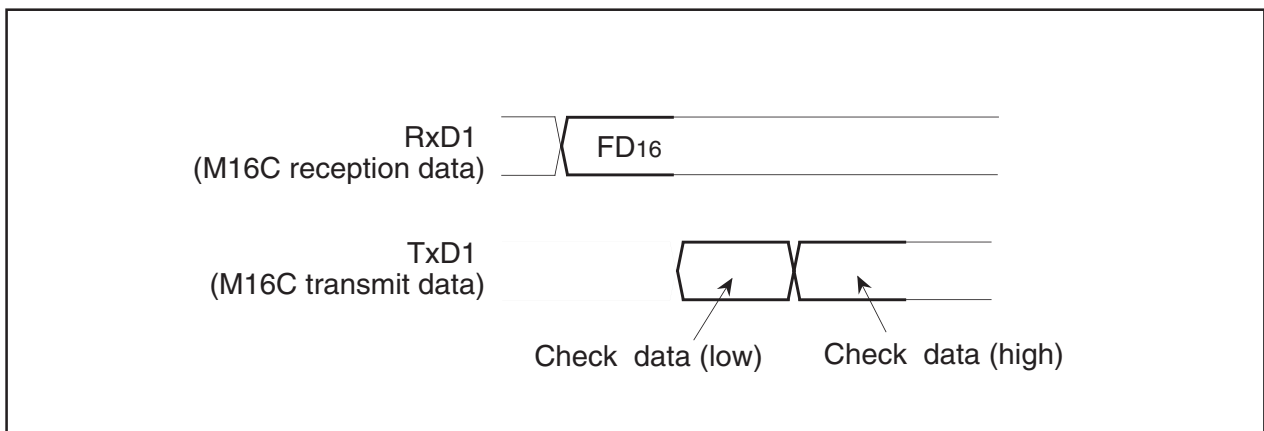

Figure 1.23.12. Timing for the read check data

Baud Rate 9600

This command changes baud rate to 9,600 bps. Execute it as follows.

- (1) Transfer the "B016" command code with the 1st byte.
- (2) After the "B016" check code is output with the 2nd byte, change the baud rate to 9,600 bps.

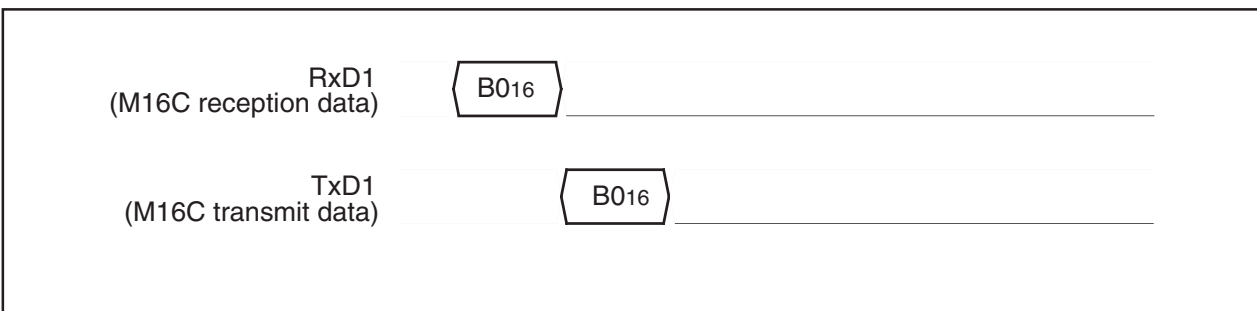

Figure 1.23.13. Timing of baud rate 9600

Baud Rate 19200

This command changes baud rate to 19,200 bps. Execute it as follows.

- (1) Transfer the "B116" command code with the 1st byte.
- (2) After the "B116" check code is output with the 2nd byte, change the baud rate to 19,200 bps.

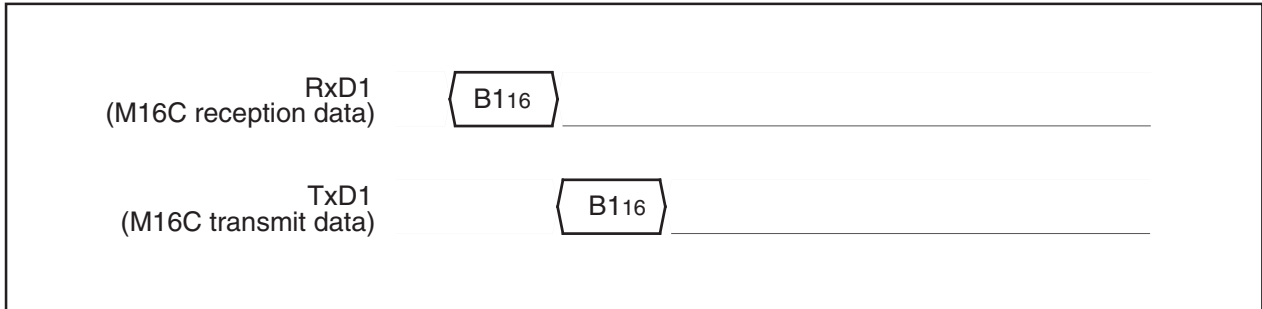

Figure 1.23.14. Timing of baud rate 19200

Baud Rate 38400

This command changes baud rate to 38,400 bps. Execute it as follows.

- (1) Transfer the "B216" command code with the 1st byte.
- (2) After the "B216" check code is output with the 2nd byte, change the baud rate to 38,400 bps.

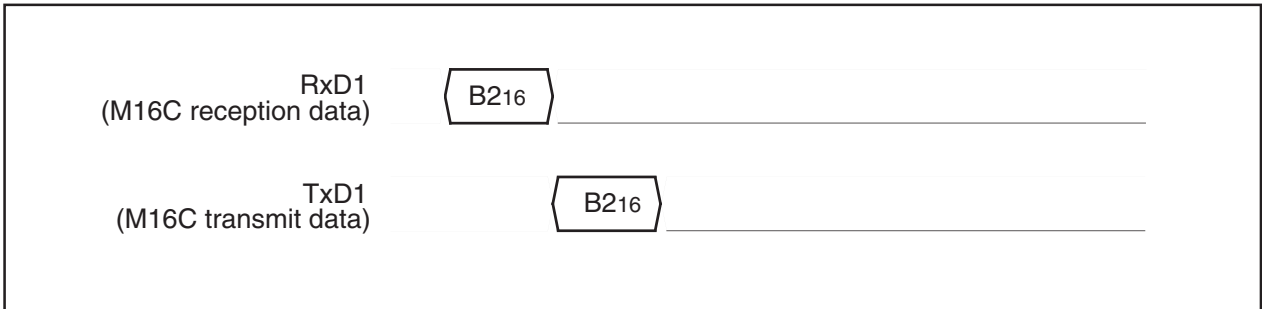

Figure 1.23.15. Timing of baud rate 38400

Baud Rate 57600

This command changes baud rate to 57,600 bps. Execute it as follows.

- (1) Transfer the "B316" command code with the 1st byte.
- (2) After the "B316" check code is output with the 2nd byte, change the baud rate to 57,600 bps.

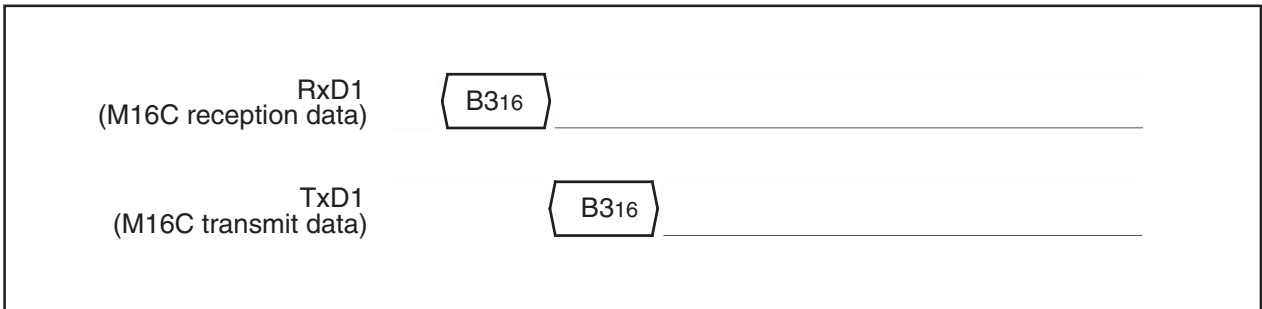

Figure 1.23.16. Timing of baud rate 57600

Example Circuit Application for The Standard Serial I/O Mode 2

The below figure shows a circuit application for the standard serial I/O mode 2.

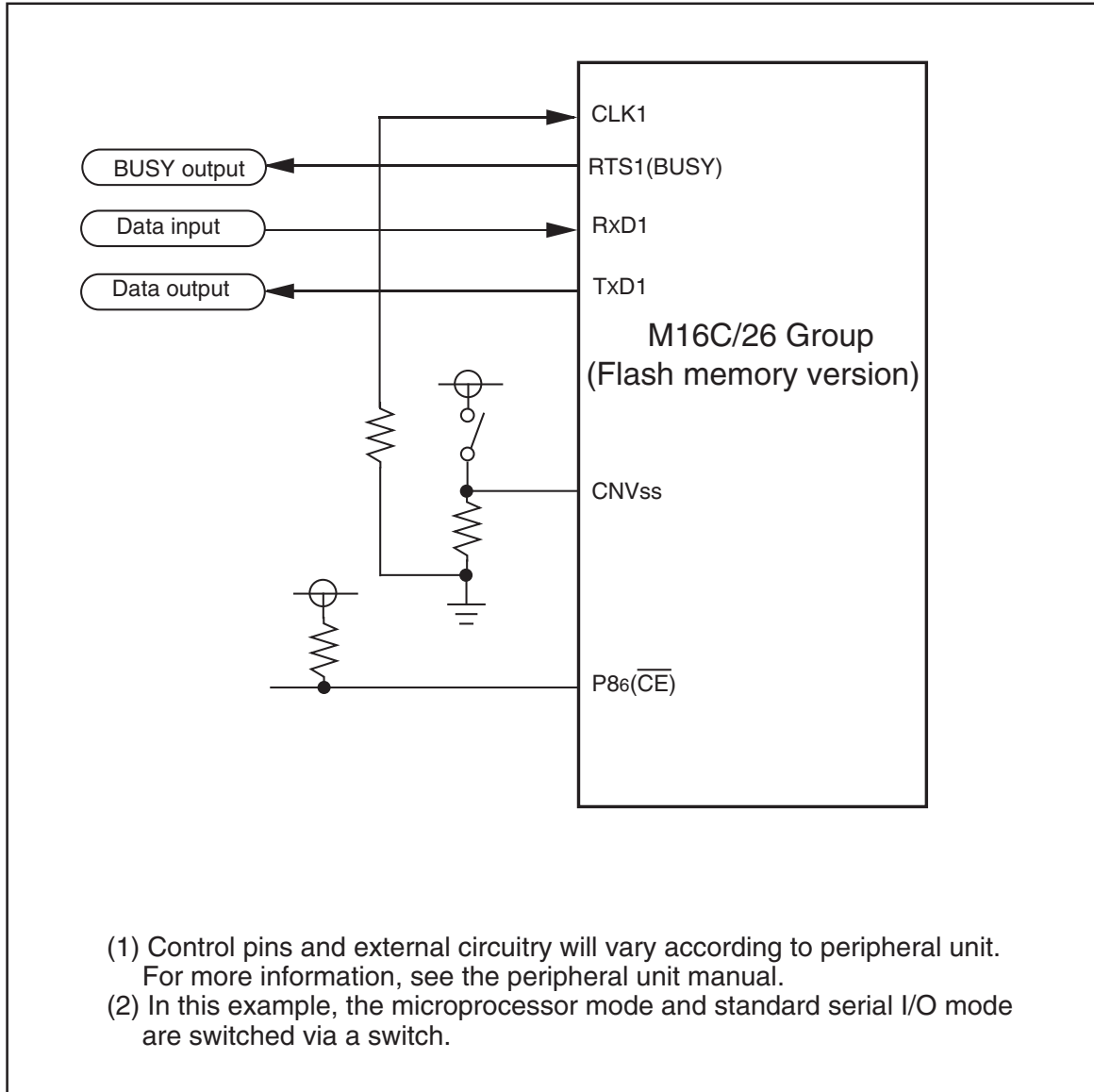

Figure 1.23.17. Example circuit application for the standard serial I/O mode 2

**RENESAS 16-BIT CMOS SINGLE-CHIP MICROCOMPUTER
HARDWARE MANUAL
M16C/26 Group Rev.0.90**

Editioned by
Committee of editing of RENESAS Semiconductor Hardware Manual

This book, or parts thereof, may not be reproduced in any form without permission of Renesas Technology Corporation.
Copyright © 2003. Renesas Technology Corporation, All rights reserved.

M16C/26 Group Hardware Manual

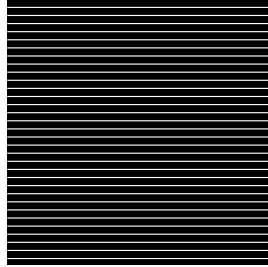

RENESAS

Renesas Technology Corp.
2-6-2, Ote-machi, Chiyoda-ku, Tokyo, 100-0004, Japan