

# RE-280RA/SA



Metal-brush motors

OUTPUT : 0.8W~4.5W (APPROX)

WEIGHT : 42g (APPROX)

Typical Applications Home Appliances : Massager / Vibrator

Toys and Models : Motorized Toy / Motorized Plastic Model

MODEL	VOLTAGE		NO LOAD		AT MAXIMUM EFFICIENCY				STALL			
	OPERATING RANGE	NOMINAL	SPEED r/min	CURRENT A	SPEED r/min	CURRENT A	TORQUE mN·m	TORQUE g·cm	OUTPUT W	TORQUE mN·m	TORQUE g·cm	CURRENT A
RE-280RA-2865	1.5~3.0	3V CONSTANT	9200	0.16	7770	0.87	1.98	20.2	1.61	12.7	129	4.70
RE-280RA-20120	3~6	4.5V CONSTANT	7500	0.080	6300	0.42	1.77	18.1	1.17	11.1	113	2.21
RE-280RA-2485	1.5~4.5	3V CONSTANT	7000	0.12	5800	0.58	1.68	17.1	1.02	9.80	100	2.80
RE-280SA-2865	1.5~4.5	3V CONSTANT	7100	0.16	6000	0.88	2.58	26.3	1.62	16.7	170	4.80
RE-280SA-20120	3~6	4.5V CONSTANT	5800	0.080	4890	0.43	2.26	23.1	1.16	14.5	148	2.34
RE-280SA-2485	3~6	4.5V CONSTANT	8100	0.13	6880	0.73	2.74	27.9	1.97	18.1	185	4.10

DIRECTION OF ROTATION

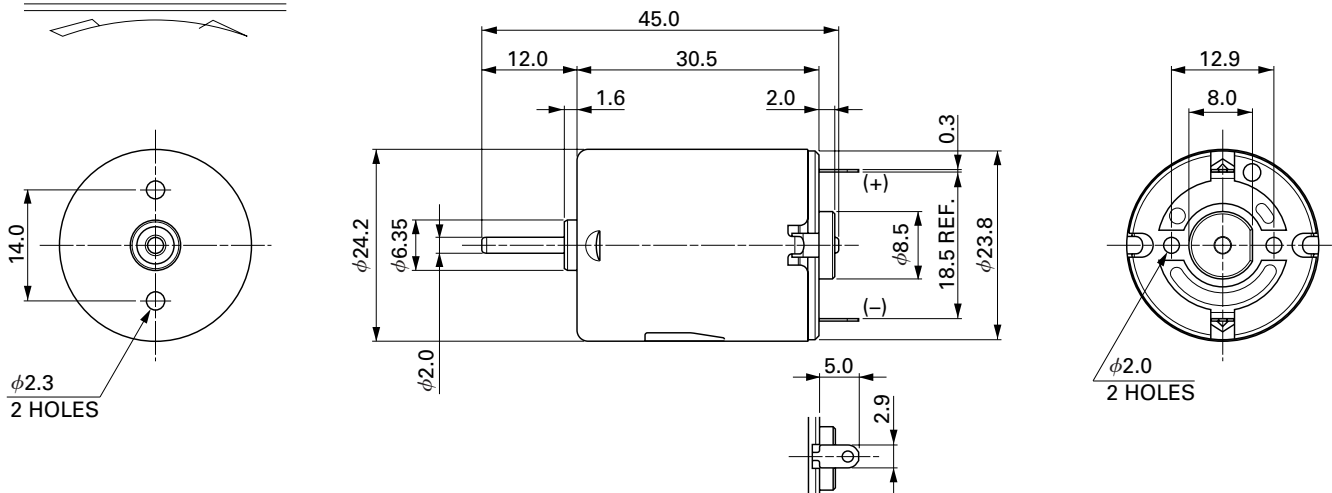

UNIT: MILLIMETERS

## RE-280RA-2865

3.0V

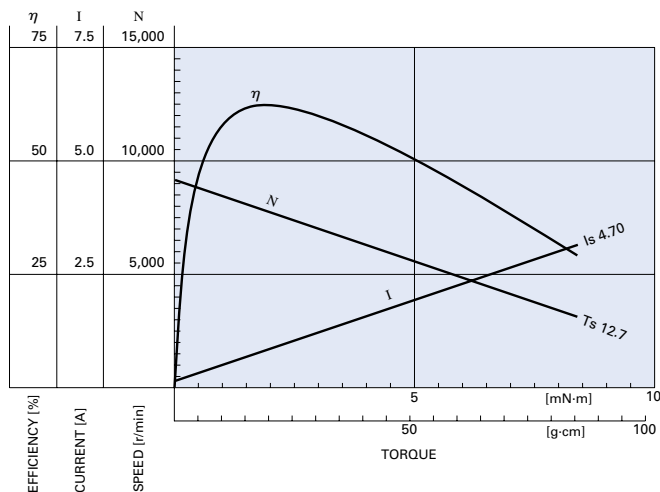

## RE-280SA-2865

3.0V

