

Lab 02: Motor Control – Tutorial

Step 1: Start LabVIEW(LV) Robotics 2009, and then create a new robotics project. The project explorer window will then pop up. Save this project as Lab2MotorControl. Once the project has been created it will automatically build and open the Roaming VI from lab 1. Minimize this for now, however, we will be copying elements of this code later.



Figure 2.1

Step 2: From the project explorer window create a new virtual interface (VI). *File* → *New VI*
Save this VI as 2x2MeterSquare. Two windows will open: the block diagram and the front panel. For the purpose of robotics we will rarely ever use the front panel as the labs in this course require autonomous operation..

Step 3: We will now start to build the 2x2MeterSquare VI. Go to the block diagram of the Roaming VI and copy the following code segments:

1. sbRIO open FPGA reference.
2. Read/Write Control (1). (*You will need to paste two copies of this segment*)
3. Read/Write Control (2).
4. Close FPGA reference.

Paste these code segments into the 2x2MeterSquare VI.

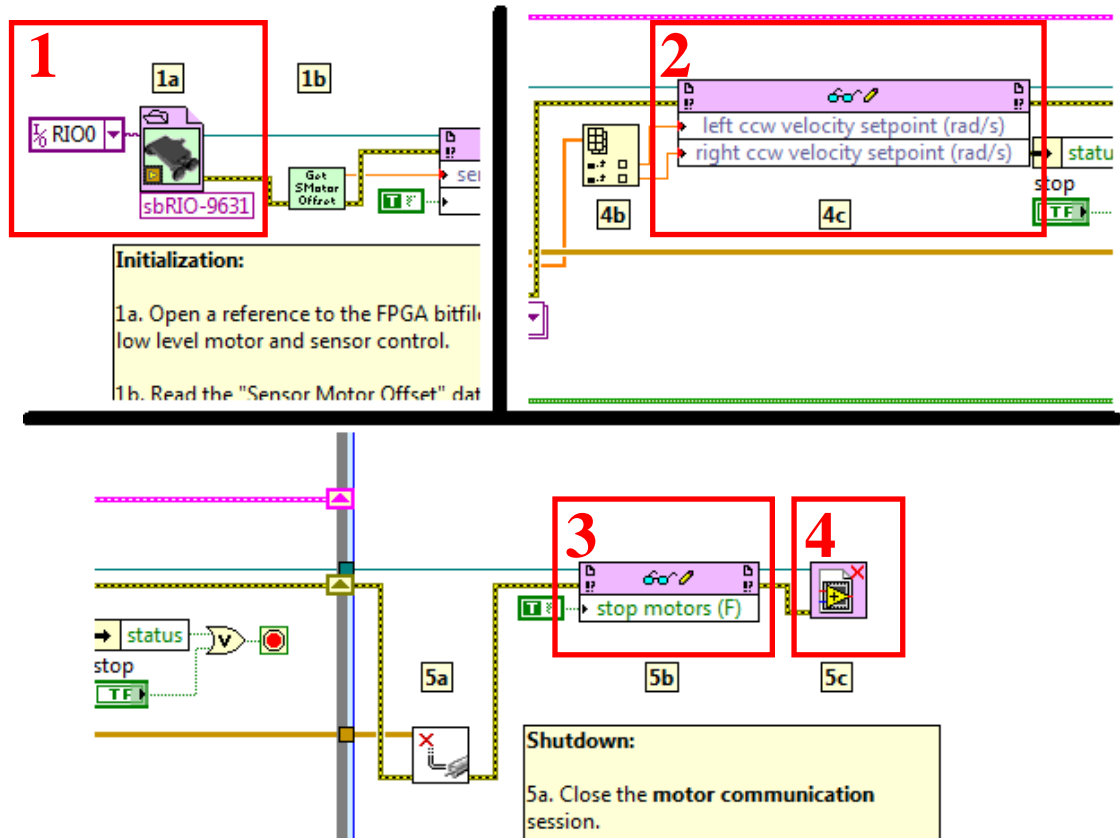

Figure 2.2

After completing step 3 your block diagram should look like the image in figure 2.3.

Note – The shown code placement was chosen to make later steps easier, however, it is not necessary to copy the placement exactly.

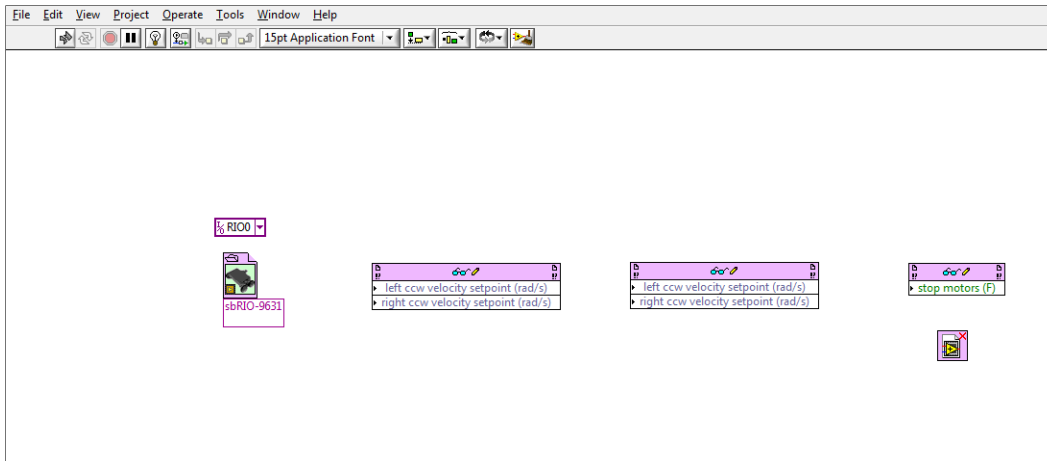

Figure 2.3

Step 4: We now need to create a way for the code to run sequentially. The goal is to have the robot move forward for a set distance, and then to make a 90 degree turn. In order to make the robot move forward and turn, we will use read/write control (1). This is the code segment we copied twice. To make this portion of the code execute sequentially, we will use a flat sequence structure. To place a flat sequence structure, right click on white space within the block diagram.

Right click → Programming → Structures → Flat Sequence

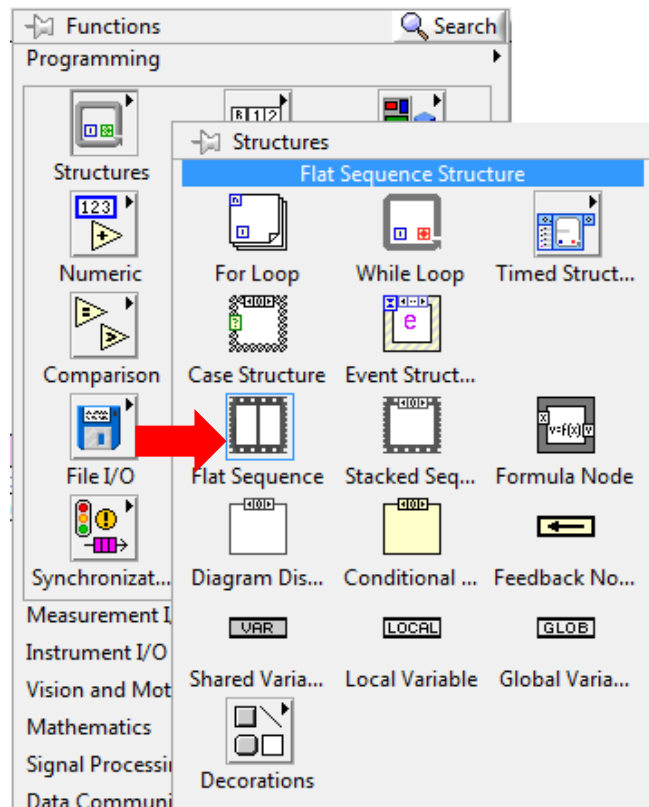

Figure 2.4

When placing the flat sequence structure, click and drag to make the loop larger. Make sure you leave enough room to fit the read/write control in as well as a few more statements we will add later. You can readjust the size of the structure as you see fit after placing. For the lab we will need two frames. Right click the boarder of the flat sequence structure and select add frame after. Readjust the new frame so that there is enough room to work with. Place the read/write controls so that your code looks like figure 2.5.

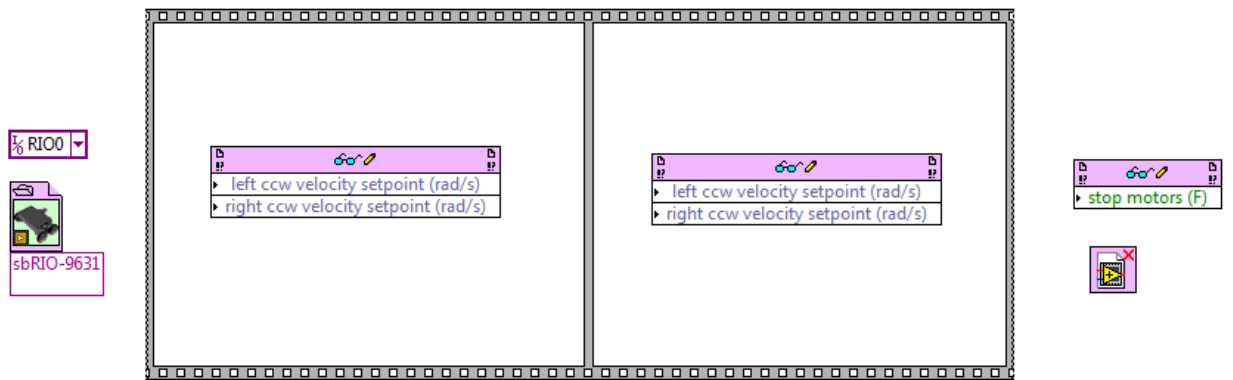

Figure 2.5

Step 5: The next part of this lab requires setting up an infinite loop. We need the robot to navigate the 2x2 meter square infinitely, so the loop must be placed around the flat sequence structure. To accomplish this we will use a while loop. Follow the same instructions used to acquire the flat sequence structure, but this time choose a while loop. *Right click* → *Programming* → *Structures* → *While Loop*. Make sure you place the while loop in such a way that it fully encompasses the fOnce this step is complete your code should look like figure 2.6.



Figure 2.6

Now that we have set up a while loop, we need to create a condition that will cause it to execute infinitely. To do this, right click on the loop condition for the while loop (The stop sign in the bottom right corner for the frame). Select Boolean Palette, and then false constant. Also ensure that “Stop if true” is selected. Place the Boolean constant next to the loop condition so that it forms a link, or wire, between the two.

Right Click → Boolean Pallet → False Constant.

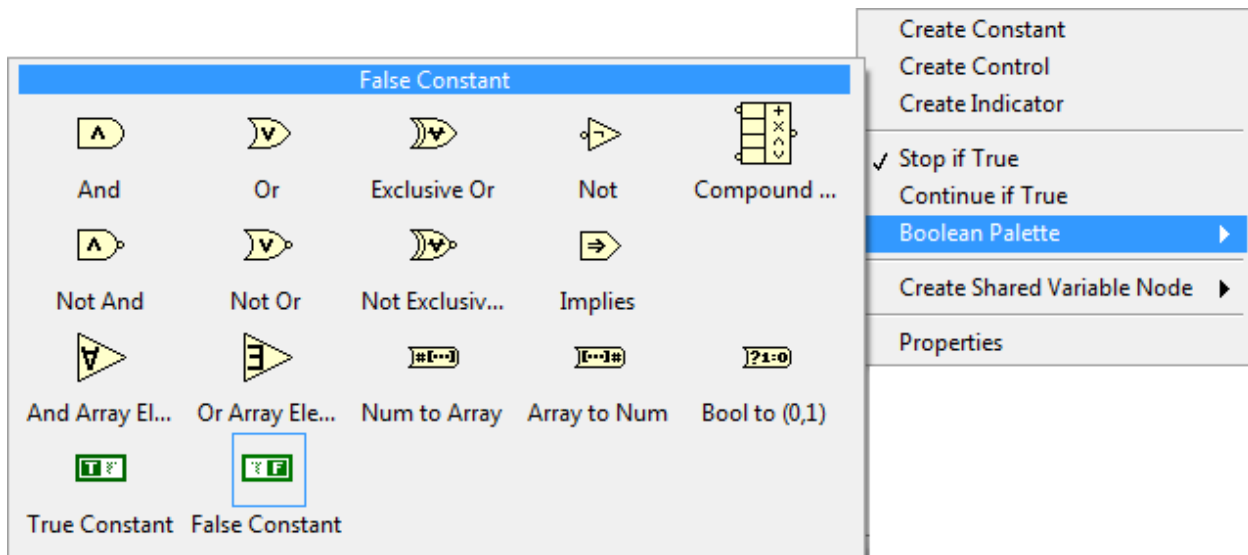

Figure 2.7

Step 6: Next we need to add wait statements to the flat sequence structure. This will cause the code within each frame of the flat sequence structure to execute for a specified amount of time. To do this, right click white space within the flat sequence structure.

Right click → Programming → Timing → Wait (ms)

For the first frame we will use the value 5000ms for the wait statement. For the second frame we will use the value 1445ms. (These are predetermined values that will cause the robot to travel 1 meter and turn 90 degrees at a certain velocity.) When you are done your block diagram should look like figure 2.8.

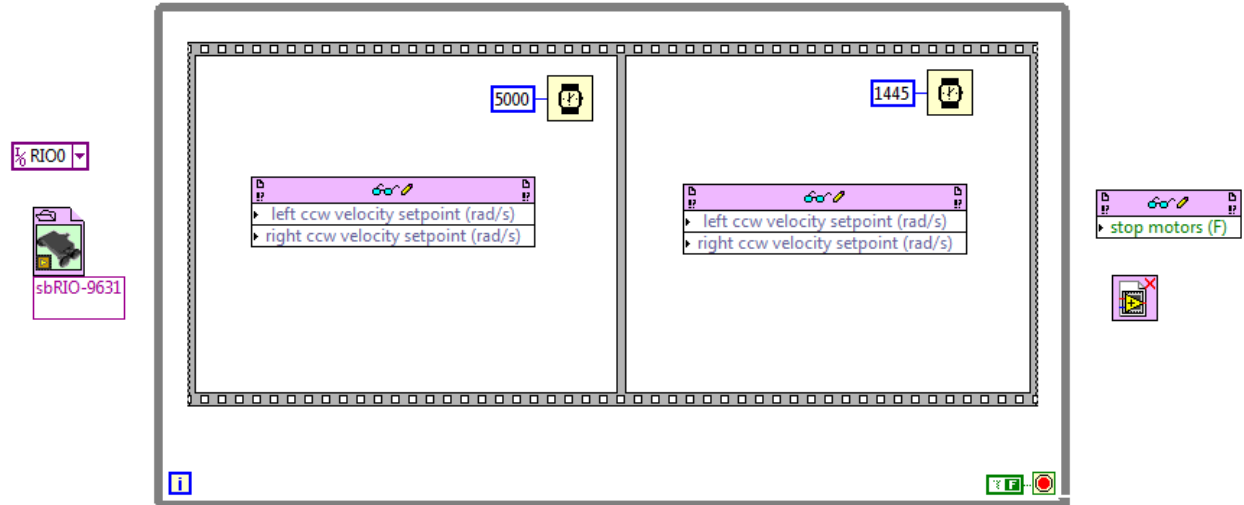

Figure 2.8

Step 7: We now need to add values to the read/write controls that control the motor velocity. The predetermined value for the velocity is 8.4 radians/second. In all you will need to create 4 constants and attach them to their specified input. Reference figure 2.9 for correct constant placement. Also note the polarity of the constants. This will determine if the motors are rotating clockwise or counter-clockwise.

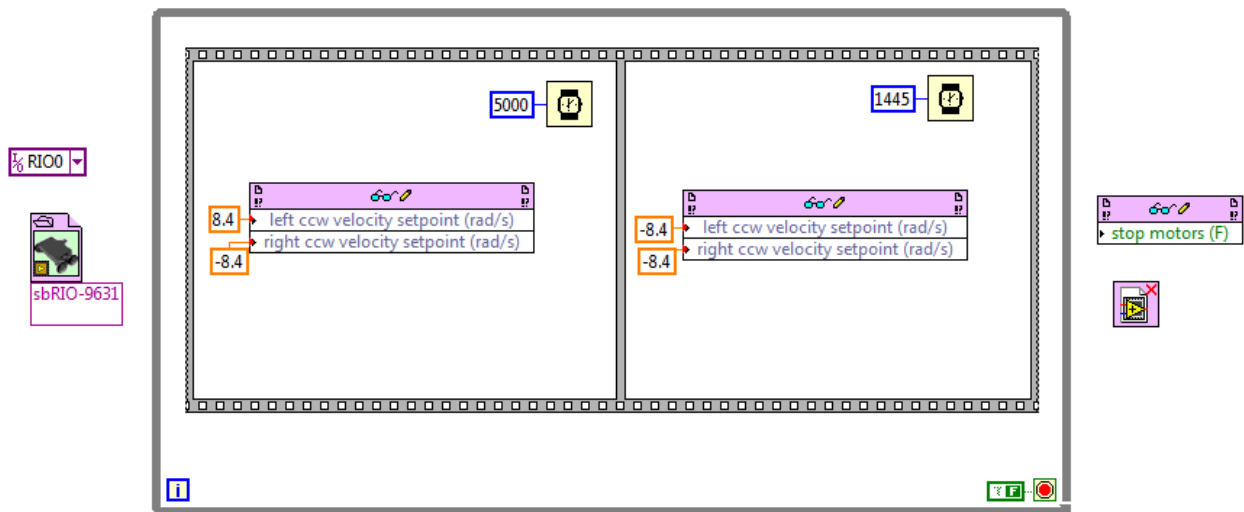

Figure 2.9

Step 8: Attach a Boolean true constant to the input of the read/write control (2). This is the one labeled stop motors.

Step 9: Connect a data wire as shown in figure 2.10

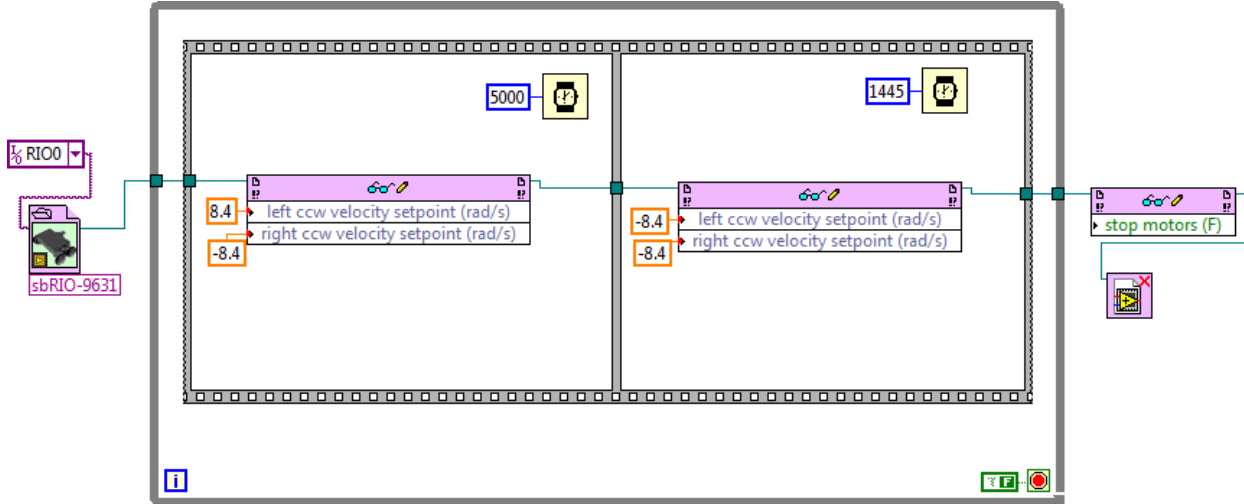

Figure 2.10

Step 10: Connect an error wire as shown in figure 2.11

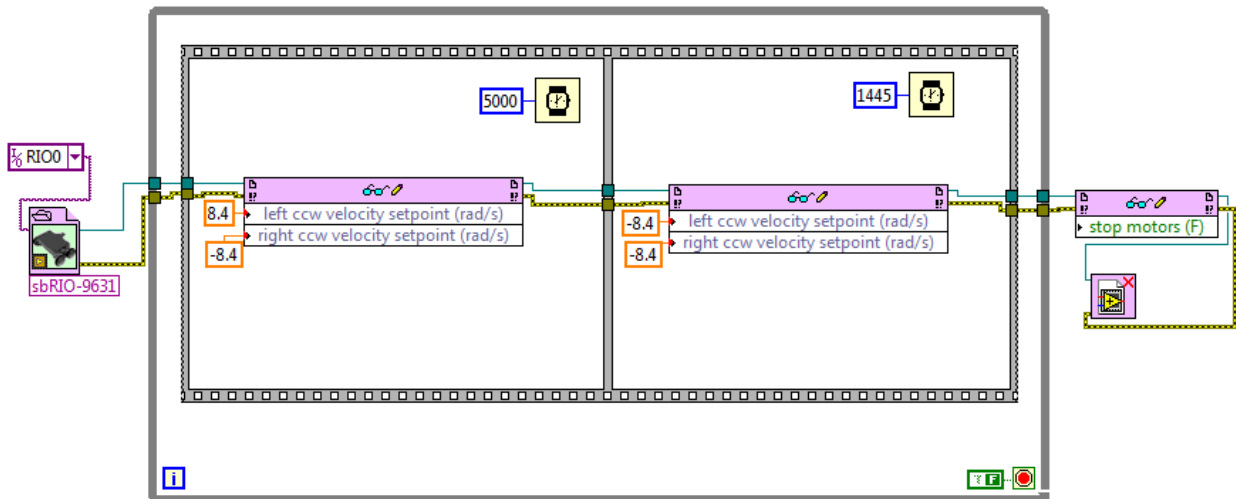

Figure 2.11

Step 11: You are ready to upload this code to the robot.