

Implementation of Smartphone Environment Remote Control and Monitoring System for Android Operating System-based Robot Platform

Authors : Sung Wook Moon, Young Jin Kim, Ho Jun Myeong, Chang Soo Kim,
Nam Ju Cha, Dong Hwan Kim



UNC CHARLOTTE

The WILLIAM STATES LEE COLLEGE of ENGINEERING

By: Ruban Kumar
ECGR 6185 Adv. Embedded Systems
April 17th 2013



UNC CHARLOTTE

The WILLIAM STATES LEE COLLEGE of ENGINEERING

INTRODUCTION

AGENDA:

- Android operating system based robot platform and smart phone operated control and monitoring system are introduced.

MOTIVATION:

- Traditional robots consists of high performance computer or microprocessor as a controller.
- Bulky or limited in computation.
- Advancement in the field of smart phones.
- Powerful smart phone applications.



iPOLiS

- Typical robot application.
- A simple haptic operation to operate a CCTV remotely.
- No extra control kit required.



URC

- Ubiquitous Robotic Companion.
- It means a robot providing a service at any place and time with users.
- It solves cost problem.

- How it Works?

In present work, a robot system was designed by integrating a smart phone technology and URC

System structure

- Figure below shows the developed robot system structure.

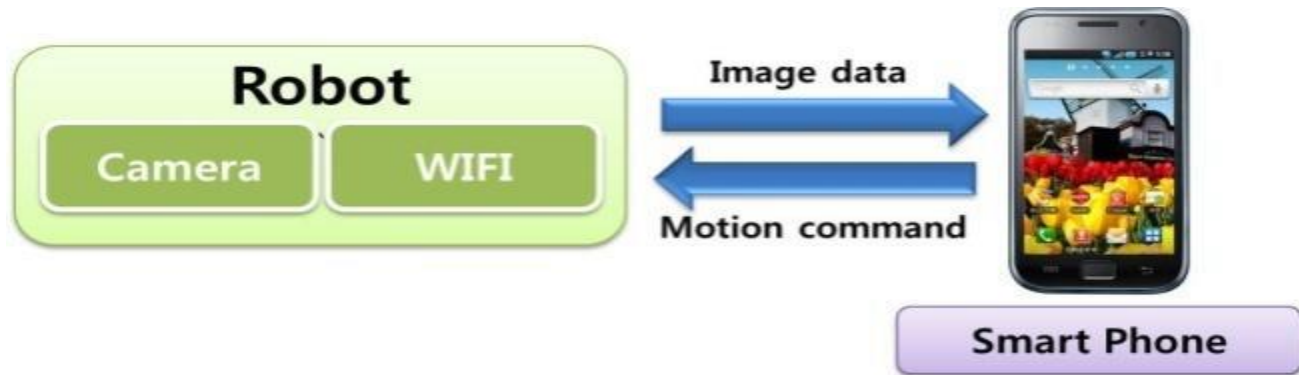

Overview

- Image Compression
- Transferring of image
- The basic UI (User Interface) was designed to control the robot.
- Using WIFI robot commands are performed.
- IC's used:
 - S5PV210
 - TMS320F2808

Controller design

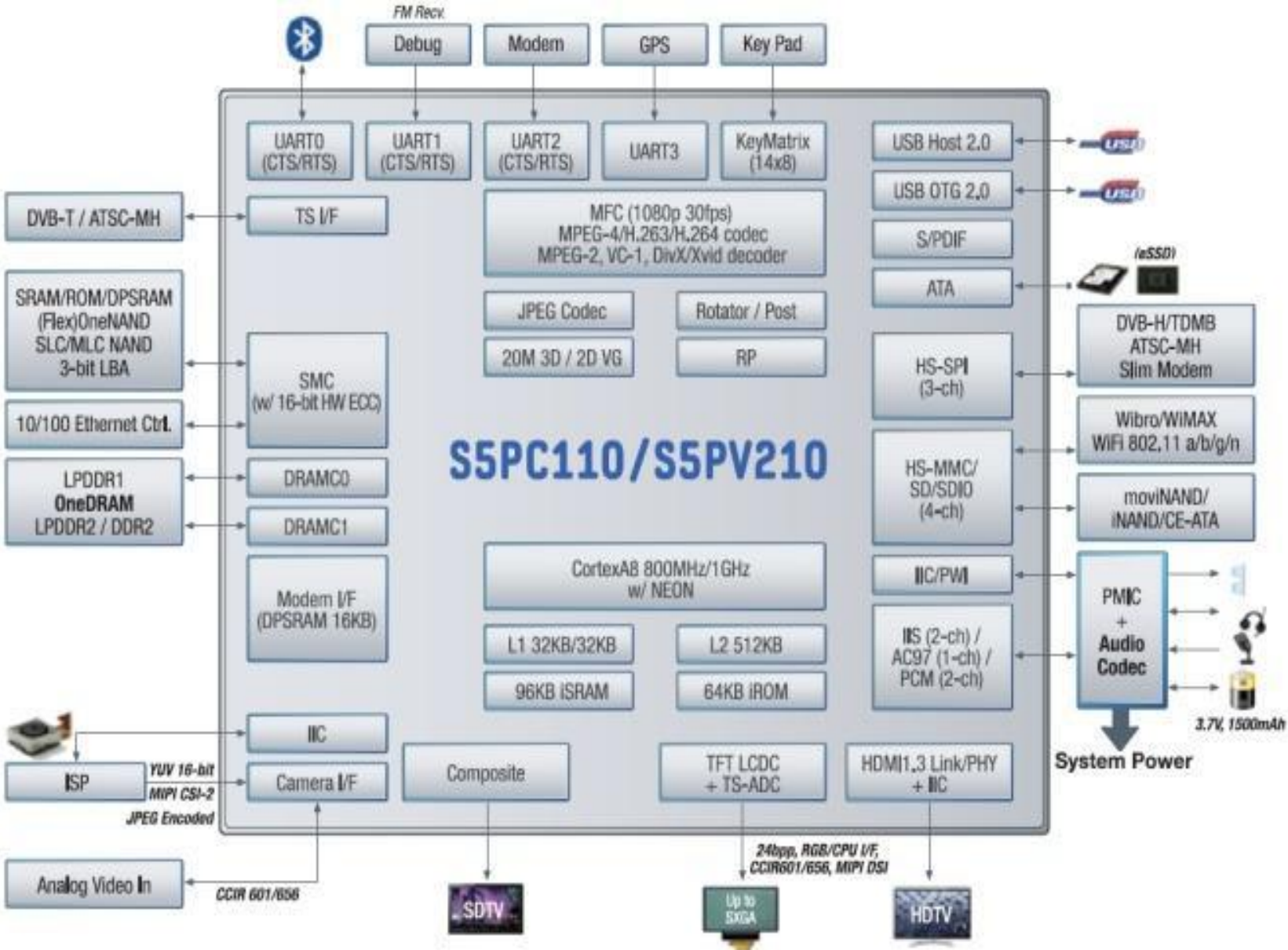

S5PV210

- From Samsung Ltd
- ARM Cortex-A8
- 1 GHz Speed and second cache for fast processing.
- Various Interfaces available.
- Easy to port OS, with the help of MMU (Memory management unit).

Limitations of S5PV210

- The android platform on S5PV210 chip plays a role in managing overall system in the robot.
- However, Android OS does not guarantee RTOS, which limits a real time control.

SOLUTION:

For real time control, a special chip DSP is selected and was put on the designed board

TMS320F2808

- With this chip a motor driving and sensor measurement could be implemented in real time.
- Between TMS320F2808 and S5PV210 a serial communication is connected.

CONTROLLER STRUCTURE

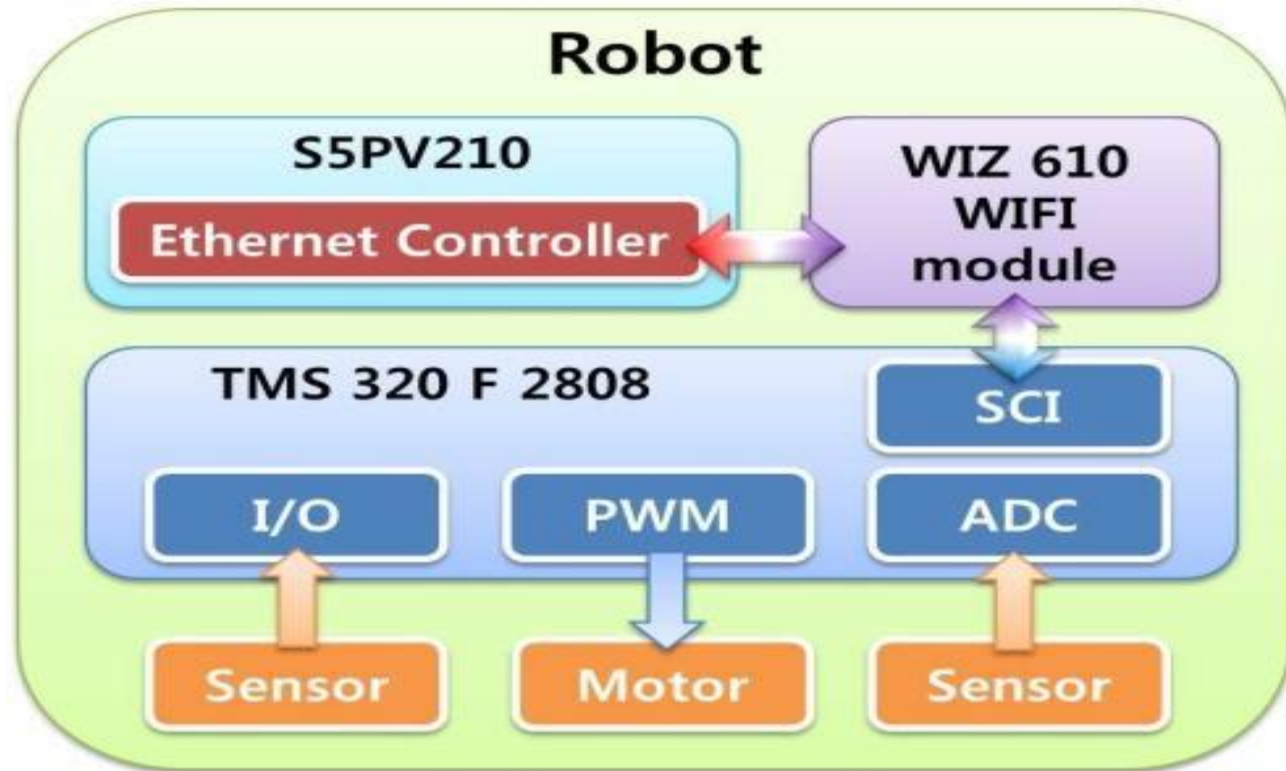

Continue ...

- It has **ADC** (Analog-Digital converter) for sensor measurement.
- **PWM** (pulse with modulation) and **QEP** (Quadrature Encoder Pulse) for motor control
- Serial communication interface (**SCI**) for communication with other devices.
- **Ethernet controller** chip for using Ethernet
- **WIFI, audio codec and Camera etc.**

ANDROID PLATFORM

- In our robot system, Gingerbread version as an Android Platform was adopted.
- JAVA language based OS.
- It provides free SDK.
- In Addition, it provides an Emulator.
- Booting the system is easy.

ANDROID ARCHITECTURE

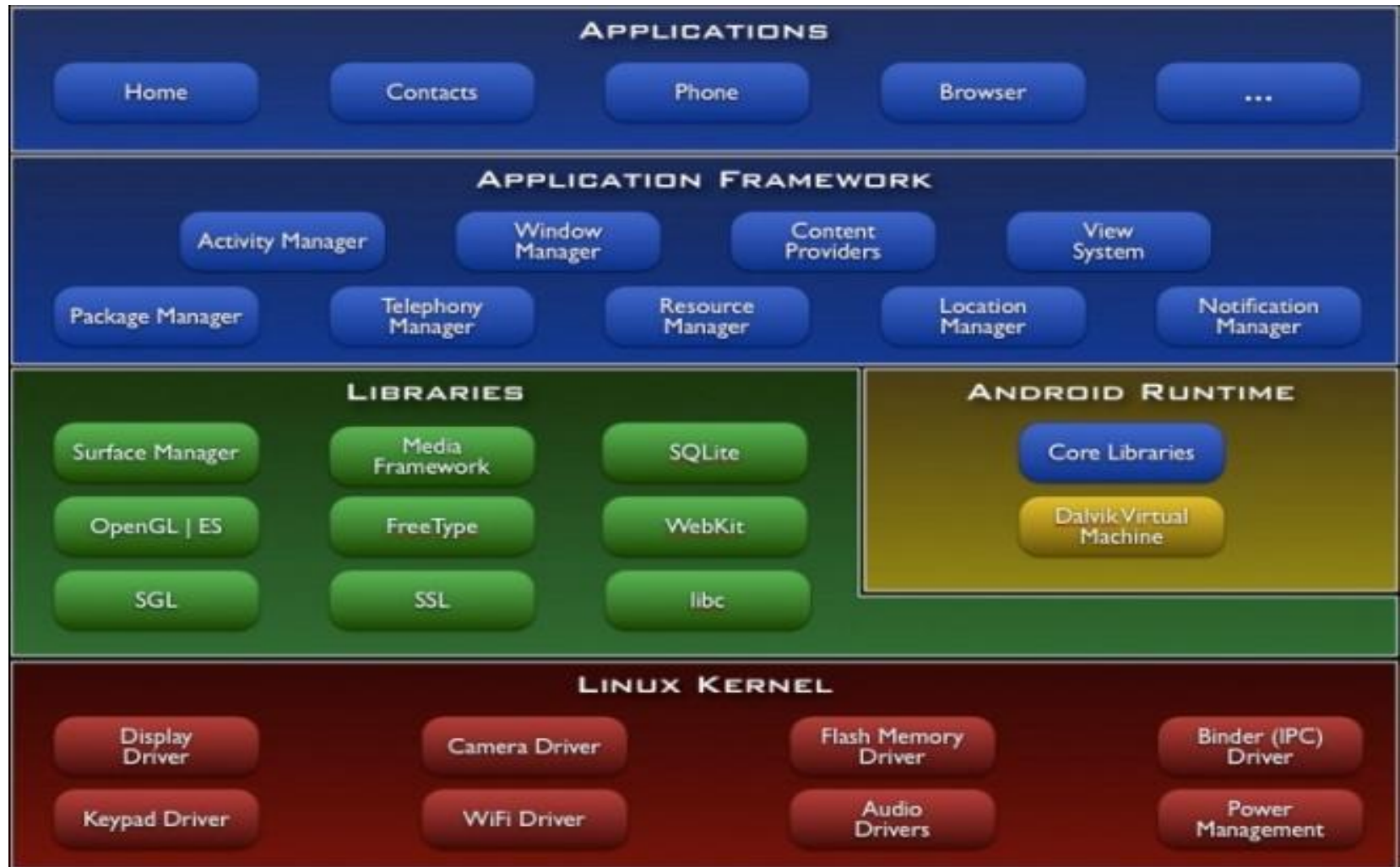

Continue ...

- In the robot ,A mango210 board from crz-technology.
- S5PV210 chip.
- supports BSP (Board Support Package)
- Developed the robot control board, integrating Android, Linux kernel, and Boot Loader.

ROBOT Mechanism

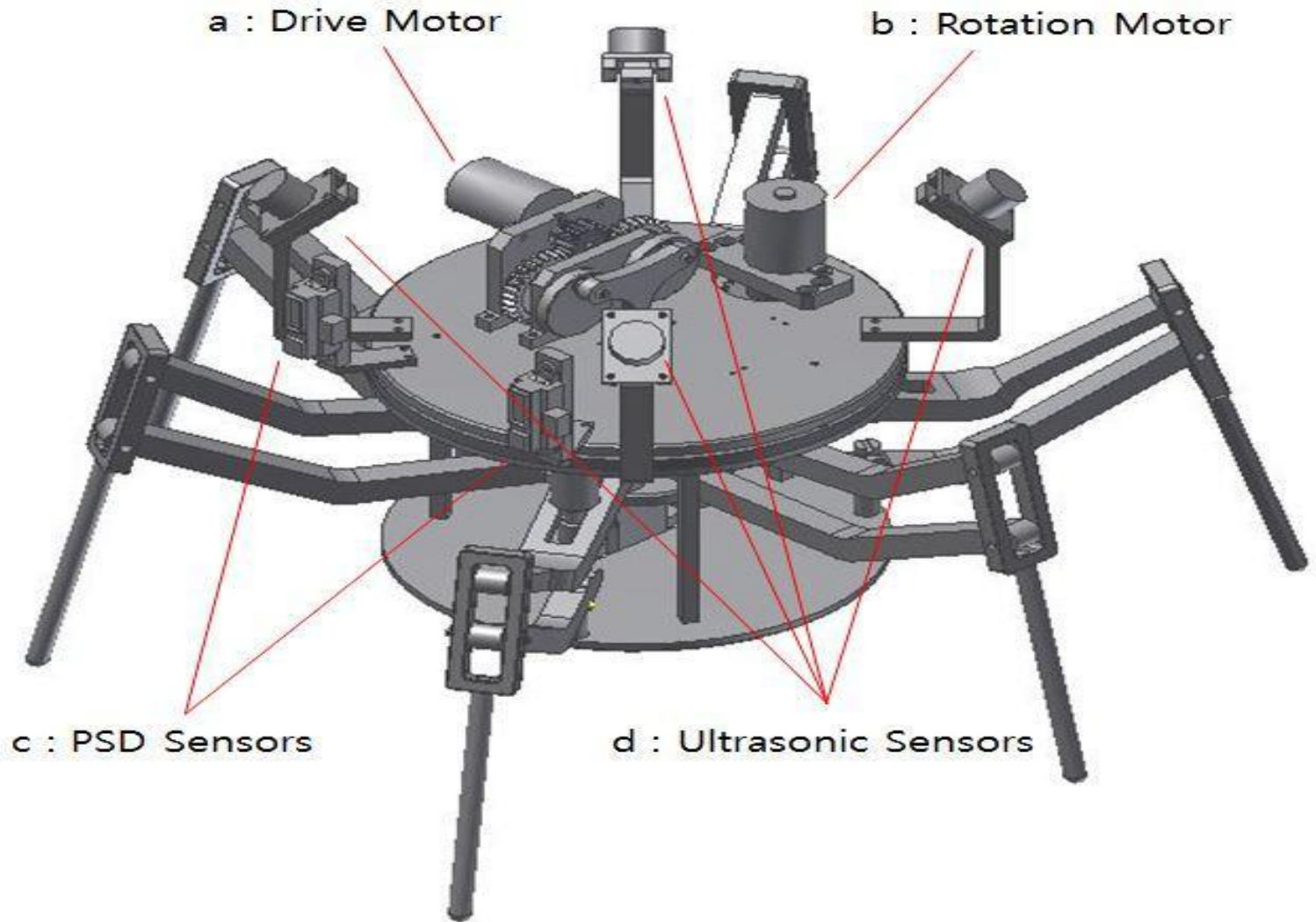

HEXPOD

- Six legs, resembling spider.
- Body made of ABS (Acrylonitrile Butadiene Styrene)
- Two PSD sensors for detection of front objects
- Four ultrasonic sensors are employed

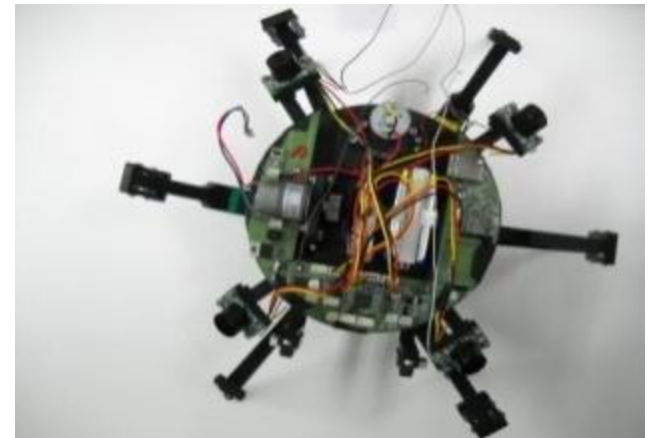
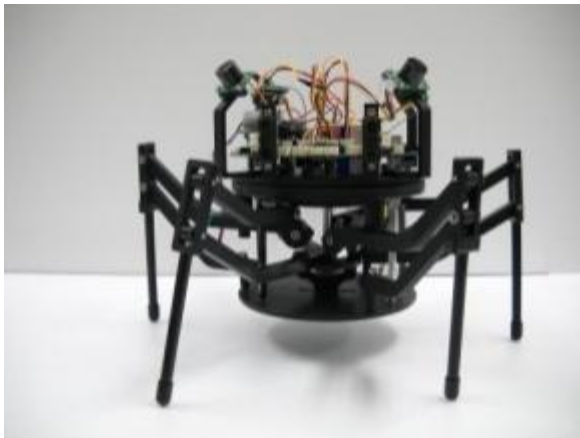

IMAGE COMPRESSION

- The function *onPreviewFrame()* in *Previewcallback* class was used.
- It is compressed by YUV420 format.
- Converting from

YUV  JPEG

Reason: Large data size not supported

Process of Image Compression



Formulas and Functions

$$\begin{bmatrix} r \\ g \\ b \end{bmatrix} = \begin{bmatrix} 1 & 0 & 1.407 \\ 1 & -0.345 & -0.717 \\ 1 & 1.779 & 0 \end{bmatrix} \begin{bmatrix} y \\ u-128 \\ v-128 \end{bmatrix} \quad (1)$$

```
Bitmap bitmap = Bitmap.createBitmap(width, height, Bitmap.Config.RGB_565);  
bitmap.setPixels(bBitmapInt, 0, width, 0, 0, width, height);  
bitmap.compress(Bitmap.CompressFormat.JPEG, 50, outstream);
```

Image Transfer & Reception

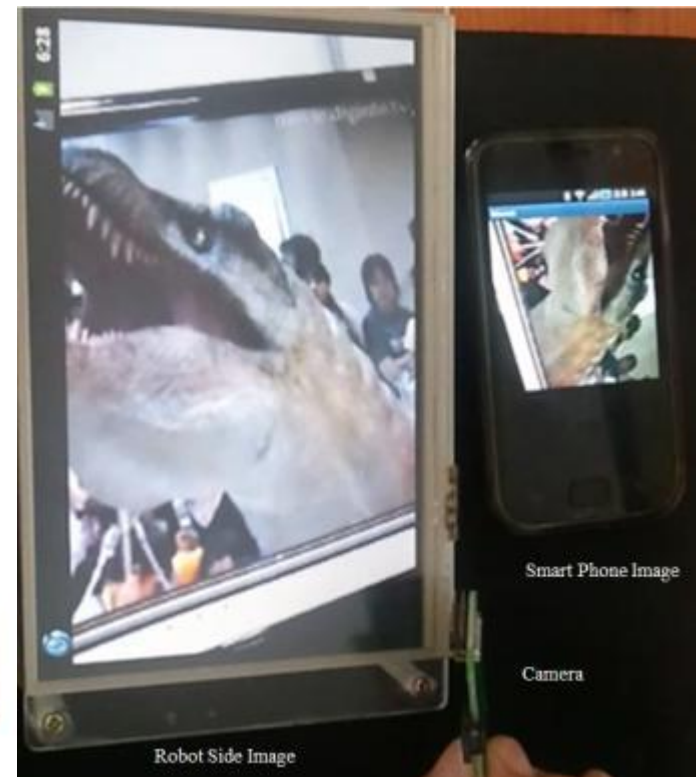
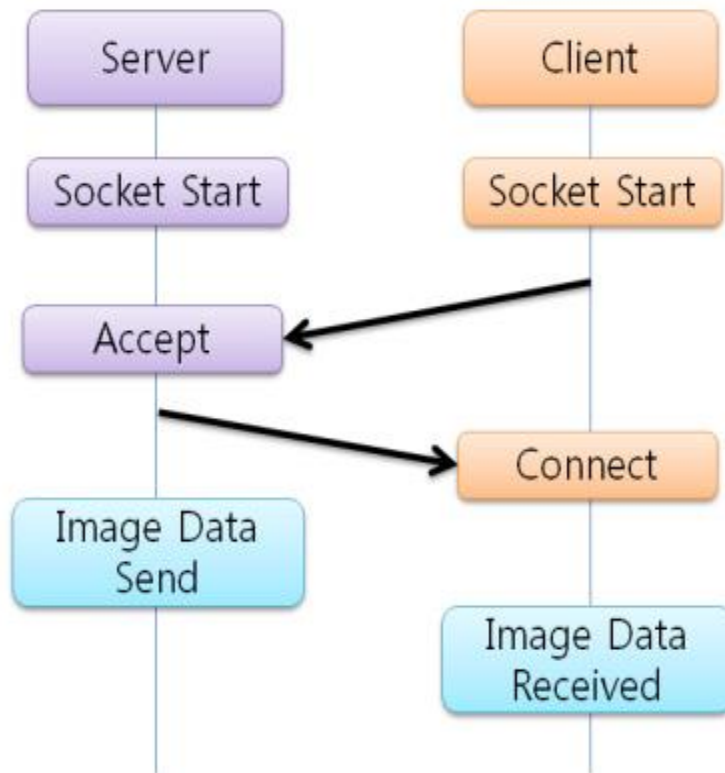

References

- Sung Wook Moon , Young Jin Kim, and Ho Jun Myeong
“Implementation of Smartphone Environment Remote Control and Monitoring System for Android Operating System-based Robot Platform” The 8th International Conference on Ubiquitous Robots and Ambient Intelligence (URAI 2011) TC 1-1 Nov. 23-26, 2011 in Songdo ConventiA, Incheon, Korea