

Embedded Systems Communication Board for Education and Research

Ishfan Vakil and James M. Conrad

University of North Carolina at Charlotte, Department of Electrical and Computer Engineering,
9201 University City Blvd, Charlotte, NC 28223
ivakil@uncc.edu, jmconrad@uncc.edu.

Abstract - Data communication is one of the most important and fundamental parts of any electrical or electronic equipment in use today. Embedded systems are integrated in almost all industry grade high technology equipment as well as in our household electrical appliances. All of these devices require data communication in different forms. This effort was to design an embedded system for use in classroom teaching that provides a platform for students to work with different modules of data communication ranging from optical fiber and infrared communication to RS232 and USB. The communication microcontroller board will provide the embedded systems student an opportunity to learn different data communication technologies by using a single embedded microcontroller package. This paper presents the tools and approach used to design the communications education board, the details of the various data communication modules used in the board and the throughputs and technical specifications of each module. The manufactured version of the board will be used in labs and classrooms to teach data communication to embedded systems engineering students.

Index Terms – Optical, Infrared, communication, embedded systems, USB.

INTRODUCTION

The transfer of data in the form of digital bits, voltages and light signals is taking place all around us. Two parts of the same electrical equipment controlling a given process send and receive control signals in the form of electrical data. Control systems that are embedded inside industrial-grade high technology equipment or as a part of many household electrical appliances require data communication either within the system, between the various components involved in that system or outside the system. It would be safe to say that data communication forms the backbone for any electronic system.

Data communication is one of the most important and fundamental parts of any electronic or electric equipment in use today. Data may be carried to a distance of less than a fraction of an inch on a printed circuit board to as far as a few hundred miles through long wires. Different devices based on their requirements use different methods of data communication. The basic aim of each device capable of data communications is to transmit and/or receive data at the highest possible transmission speed with the lowest possible

transmission error, consume the lowest possible power, and cost the least amount of money possible.

Data is transmitted through communication channels, which are pathways through which data flows from the transmitter to the receiver. Communication channels can vary depending upon the type of application and the transmission requirements. They can be either wireline or wireless channels. The wireline communication channels physically connect the transmitter to the receiver with a wire that could be a twisted pair, a coaxial cable or an optical fiber. The wireless communication channel requires no physical connection between the transmitter and the receiver. Data is transmitted through air where the transmitter having an antenna radiates signals that can be received by another antenna at the receiving end.

The speed at which data can be transmitted between a transmitter and a receiver is called data transfer speed or simply data rate. In a digital communication channel, the data is represented by individual bits that may be combined to form multibit message units. A byte, which consists of eight bits, is an example of a message unit that data rates are measured in megabytes per second (Mbps), kilobytes per second (Kbps) or simply bytes per second (bps). The data transfer rate or simply data rate is also termed as throughput. The throughput of a device would thus be defined as the number of data bits transferred per second.

Embedded system is one of the fields where data communication holds a very important place. Embedded communication devices are integrated into different applications ranging from homeland security system to industry automation to simple home appliances. With these significant technological advancements in the field of data communication and the subsequent development of high technology equipment and gadgets comes the need for teaching the latest technology in data communication to the upcoming engineering students. Embedded system engineers have knowledge about computer architecture, microcontrollers and programming. The demand of embedded engineers having knowledge about data communication is going to be high. However there are very few development tools available for classroom teaching which handle data communication. Many commercially available evaluation embedded microcontroller boards usually have very few or no communication module available on them, so the engineering

students usually do not learn much about different data communication technologies.

The goal of this design effort was to create a communication hub or an embedded systems communication board (ECB) that can be used in labs and classrooms to teach data communication to embedded system engineering students. This paper presents the design and testing of the embedded systems communication board.

BOARD SPECIFICATIONS

The embedded systems communication board or ECB has been designed keeping in view the basic needs and requirements of a typical evaluation board that can be used by embedded systems students to learn the basics of embedded system programming, debugging and hardware details. However additional details which are the highlight of this board and make it different from any other board available in market today for classroom teaching is the availability of high technology communication modules on it. There are many products in the market which can be used for classroom teaching of embedded systems, however most of them consist of a single microcontroller along with a number if I/O pins and some debugging switches and LEDs. As a contrast to these boards the embedded systems communication board in addition to these basic modules supports Optical Fiber, Infrared, serial RS232 and serial USB. Having all these modules on a single board make learning easy.

The board has been designed using small package and surface mount devices to reduce the over all complexity of the design and the size of the board. The board is targeted to be of 4 square inch in size. The devices selected for the board have been chosen to be low power consuming in accordance with one of the major requirements of any embedded systems product.

The following figure shows the basic block diagram of the embedded systems communication board. The block diagram serves as the basic blueprint for the later design. All the major devices and communication modules have been shown in the block diagram and the design of the board was completed by following this block diagram.

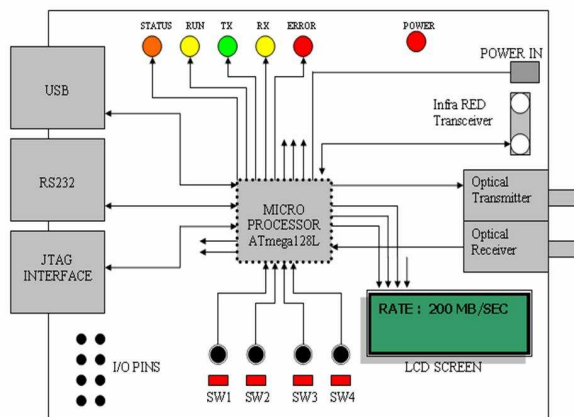

FIGURE 1
BLOCK DIAGRAM OF THE EMBEDDED SYSTEMS COMMUNICATIONS BOARD [ECB].

Each of the modules shown in the block diagram are independent of each other and works at different baud rates depending upon their specification. The board is powered through a DC voltage supply between 9V to 15V. The board carries a voltage regulator that brings down the voltage to 5V. The voltage regulator circuit has been specifically designed for this board. The board can also be alternatively powered through the USB port, giving the port additional functionality. All the components on the board have been chosen in order to operate in this voltage range. To make the board work as a low power communication hub, low power consuming devices including the microcontroller have been chosen with no or very less compromise with the price. The board has been equipped with a LCD screen, giving it an additional user-friendly look. Baud rates, bit error and/or current state of the microcontroller are some of the things that can be displayed on the LCD screen by programming the board. The embedded systems communication board kit will come with a number of test codes that can be downloaded on the board through the PC using a JTAG connector. The test codes will be able to test the functionality of each module on the board. A user will be able to alter and improve upon those test codes depending upon the requirement.

HARDWARE

The optical communication transceivers that include both fiber optic and infra red transceivers form the main data communication ports on the board. The entire board has been initially designed based upon these two data communication channels. However apart from the optical communication, the board will be capable of handling serial data communication through the serial RS232 port. In addition to the serial port a USB port has also been provided. The USB port will not only be capable of handling data communication but will also provide an alternate voltage source to the board. The JTAG (Joint Test Action Group) interface present on the board is used for downloading code from the PC to program the microcontroller. Apart from the data communication modules the board has a regulated power supply circuit which delivers regulated 5V supply to the entire board. Debugging switches and LEDs and a LCD screen also form the part of the hardware of the ECB. In this section of the paper the hardware used on the board will be discussed in detail starting with the microcontroller which forms the most important part of the embedded board, followed by the hardware required for each data communication module. The later section on hardware will deal with the debugging switches, LEDs and the LCD screen used and in the end will conclude with the power supply circuit hardware of the board.

- **Microcontroller:** The embedded systems communication board utilizes an ATMEL ATmega128L [11] an 8-bit AVR microcontroller. It is a high performance, low power, 8 bit AVR® microcontroller. It comes with a 128Kbytes of self-programmable flash, 4Kbytes of EEPROM and 8Kbytes of internal SRAM. The

microcontroller comes with a JTAG interface for programming. The processor speed ranges from 0 to 16 MHz in the voltage range of 4.5 to 5.5V. As far as the data communication is concerned the ATmega128L carries two programmable UARTs. It is capable of Master/ Slave SPI interface and byte oriented 2-wire serial interface. It comes with two 8 bit and four 16 bit timers, four 8-bit PWM channels, 8-channel 10 bit ADC and 51 programmable I/O lines making it an ideal microcontroller for the embedded systems communication board (ECB). A comprehensive set of development tools are available for the ATmega128L microcontroller.

- **Optical Fiber Transmitter and Receiver:** The optical fiber communication module used for the embedded systems communication board uses separate transmitter and receiver circuits. The module used is the Agilent technologies HFBR-1412 [12] as the transmitter which is capable of speeds in excess of 10 Mbps (Mega bits per second) and HFBR-2412 as the receiver that is capable of speeds up to 5Mbps. The Agilent optical fiber transmitter and receiver are low solution for optical fiber data communication for up to distances of 2.7 km.



FIGURE 2
HFBR-0400 SERIES: OPTICAL FIBER TRANSCIVER

- **Infrared Transceiver:** The IR transceiver used for the embedded systems communication board is the TFDU4100 Serial Infrared Transceiver (SIR) from Vishay Semiconductors [13]. The TFDU4100 is an infrared transceiver module compliant with the IrDA (Infrared Data Association) standard for serial infrared (SIR) data communication, supporting speeds up to 115.2kbit/s.



FIGURE 3
TFDU4100: INFRARED TRANSCIVER

The transceiver module consists of a PIN photodiode, an infrared emitter, and a low-power analog control IC to provide a total front-end solution in a single package.

- **Serial RS232 port:** The RS232 is a popular serial data communication protocol used to connect the PC with various data acquisition devices or microcontroller boards. The RS232 device can be directly connected to the computer through its COM port or communication port. The main aim of the RS232 port to be put on the communication educational board was to have an option of data communication between the PC and the board. A female DB9 connector pin is provided on the board for the RS232 connection that is connected to the microcontroller through a serial transceiver driver chip. The circuit details and the pin configuration along with the transceiver driver chip used will be discussed in the later part of this paper.
- **Serial USB port:** A Universal Serial Bus or simply USB is one of the most popular and easy to use data communication ports in use these days. It gives us a maximum data rate of 480Mbps per second. The USB cable consists of two power lines, ground and +5V and a twisted pair that carries data. In the communication board the USB port has been interfaced with the microcontroller through the UART pins. The connection between the PC and the microcontroller UART via the USB takes place through a FT232BM USB UART IC, used for Asynchronous Serial Data Transfer. The chip supports 7 or 8 data bits, 1 or 2 stop bits and a parity bit. The chip uses an external 6 MHz crystal oscillator. The details will be discussed in the interface part of this paper. The USB port gives an additional power supply to the communication board. It provides a regulated 5V supply in addition to the main regulated power supply from the board's main power circuit.
- **Debugging switches and LEDs:** Switches and LEDs are provided on the board of debugging purposes. There are four switches and four LEDs present on the communication board. The switches used are the small 4mm J hook surface mount switches having a maximum current rating of 100mA. Each of the switches has been connected to a 10K pull up resistors. All the switches and LEDs can be programmed and are connected to the microcontroller through the programmable I/O pins.
- **LCD Screen:** The LCD module used for the board is the ACM0802C, from AZ, Displays, Inc. It is an 8x2 LCD module (8 characters and 2 lines). The ACM0802C was chosen for the communication board because of its simplicity of use. The LCD can be used and programmed to display the results and status of various data communications taking place on the board. Data rates and data error rates are some of quantities that can be displayed on the LCD screen.

INTERFACING AND SCHEMATIC DESIGN

The board schematic has been designed using cadence ORCAD capture® tools. The entire board design is divided into five parts for the ease of the design.

- **Microcontroller Circuit:** The first part of the schematic design is the microcontroller circuit. This part of the schematic carries the ATmega128L microcontroller and the related components. A total of 51 I/O pins have been made available on the board for interfacing. Two external crystal oscillators, 32,768 KHz and 8.0 MHz are connected to the Microcontroller through selection jumpers. A header for JTAG (Joint Test Action Group) interface is connected to the microcontroller for downloading code and programming.
- **Optical Transceiver Circuit:** The second part of the schematic design consists of the optical transceiver circuits (both optical fiber and infrared). The transmit pin and the receive pin of the transceiver are connected to the UART0 of the ATmega128L controller. Since the microcontroller comes with only two UARTs, UART0 and UART1, the outputs of both the transceivers, i.e. infrared TFDU4100 and optical fiber HFBR have been connected to the same UART0 using selection jumpers. As such at any one time only one of the two optical communication modules can be put to use. The coupling circuit used with each optical transceiver has been taken directly from the recommended circuits from the data sheet.
- **Serial RS232 Circuit:** The third part of the schematic design consists of the RS232 serial port design, the LCD screen interface and the debugging switches and LEDs. The DB9 connector used for serial RS232 communication as discussed in the earlier part of the paper is interfaced with the microcontroller through the MAX202 IC chip. The MAX202 transceiver IC is designed for RS232 communication interface for use in voltage levels less than 12V. The IC is used to level shift the board 5V to $\pm 12V$ required for RS232 output levels. It allows data rates in excess of 120kbps in standard conditions. It consumes around 8mA of current. The MAX202 comes in a 16 pin surface mount package. The output of the transceiver IC is interfaced through the UART1 pins of the microcontroller.
- **USB Circuit:** The fourth part of the schematic design is the USB port circuit schematic. The coupling circuit used with the USB miniB connector is shown in Figure 6. The USBDM (USB Data Minus) and USBDP (USB Data Plus) are the pins of the USB UART transceiver IC (FT232BM) [13]. The FT232BM comes in a 32-pin surface mount package. Two LEDs are connected to the TXLED and RXLED pins of the Transceiver IC. These LEDs indicate transmit and receive activity of the transceiver IC. An external 6MHz crystal oscillator is connected to IC.

- **Power Circuit:** The fifth and the last part of the schematic design is the important power circuit schematic. The power circuit has been designed keeping in mind the voltage ratings and the different voltage ranges within which all the components present on the board work reliably. The board can be connected to a voltage source ranging between 9V to 15V DC. Since the voltage coming into the board has to be brought down to an operating range of regulated 5V DC for the board to work. A bridge rectifier circuit followed by a 5V DC regulator has been used for this purpose. The bridge rectifier is a standard DF10S surface mount IC chip, with high current and high surge current capabilities. The voltage regulator used is a standard 78M05A, positive regulator. It employs internal current limiting, thermal shutdown and safe area protection, making it less prone to failure. Two power slide switches are provided on the board. The first is used to manually control the power on the board and the other one is used to switch between the main power supply from the power circuit and the one coming from the USB port.

TESTING OF THE BOARD

The design of the board has been tested for its correctness by using the STK500 evaluation kit for AVR microcontrollers. All of the circuits have been tested by connecting the various components on the breadboard and interfacing with the STK500 evaluation kit. The microcontroller has been programmed to test the various modules. Drivers for the LCD and RS232 hardware have been written and tested with the sample or test code. The testing of the design is very important as far as the manufacturing of the board is concerned. Unless the test of the design proves that all the circuits will work as specified in the requirements and schematic design, the board cannot be sent for manufacturing. The microcontroller is programmed using AVR Studio4. The AVR Studio® 4 is the professional Integrated Development Environment (IDE) for writing and debugging AVR® applications in Windows® 9x/NT/2000/XP environments. AVR Studio 4 includes an assembler and a simulator. A JTAGICE mkII connector is connected between the PC and the board to download code to the ATmega128 microcontroller through the JTAG connector. The AVR JTAGICE mkII combined with AVR Studio® can program all AVR 8-bit RISC microcontrollers with a JTAG interface.

THEORETICAL ANALYSIS

Table 1 shows the different modules present on the communication board along with their rated maximum speeds for communication.

TABLE I
DEVICE THROUGHPUT

Module or Device	Max. device Throughput	Throughput via UARTs
HFBR-1412	10 Mbps	2.5 Mbps *
HFBR-2412	5 Mbps	2.5 Mbps *
TFDU	0.115 Mbps	0.115 Mbps
USB	480 Mbps	2.5 Mbps
RS232	-	0.120 Mbps **

* The UART throughput has been calculated using the crystal oscillator frequency of 20.0 MHz and bit error of 0.0 %.

** Maximum rate allowed with MAX202 driver IC.

As shown in Table I the USB has the highest throughput compared to the rest of the communication modules used in the board, however the throughput reduces to only 2.5 Mbps via the UART of the microcontroller. If the oscillator frequency of the microcontroller is further reduced the throughput via the UART will also be reduced. The slowest communication module in the board is the infrared transceiver, with a throughput of 115.2 Kbps. Transmission of data from one module to another through the microcontroller will be completely limited by the UART throughput. If we consider an example of data communication from a PC through the RS232 port to the optical fiber transceiver, via the UART of the microcontroller, the data rate will be limited to a maximum of just 2.5 Mbps as compared to the maximum rated value of 100 Mbps for the optical transceiver. The same data communication via the I/O pins of the microcontroller will, however, be more and will depend upon the software (programming efficiency) and the oscillator frequency of the microcontroller.

CONCLUSION AND FUTURE WORK

Data communications forms a very important part of any embedded systems technology. To have a thorough knowledge of how the data communication takes place in various modules, the embedded systems engineer needs to have hands-on experience in using these technologies. There are very few evaluation tools or educational boards available in the market that has all these communication modules. The embedded systems communication board provides the single board solution or platform to work with all the different technologies for data communication for the embedded systems engineer. Test codes and sample code will be provided with each board for students to test and work with the different communication modules on the board. Future work may include development

of course materials for teaching embedded systems in classroom using the embedded systems communication board and developing lab exercises for students to perform experiments on the board.

REFERENCES

- [1] B. Kamali, "Development of an undergraduate structured laboratory to support classical and new base technology experiments in communications," *IEEE Transactions on Education*, v 37, n 1, Feb, 1994, pp. 97-105.
- [2] B. Kamali, "A Three-Level Structured Laboratory to Support Traditional and New-Base Technology Experiments in Communications," NSF Award No. 9153146, University of Texas at San Antonio, May 15 1991 to Oct 31 1993.
- [3] L. Sevgi, "EMC and BEM engineering education: Physics-based modeling, hands-on training and challenges," *IEEE Antennas and Propagation Magazine*, v 45, n 2, April, 2003, p 114-119.
- [4] V.E DeBrunner, L.S. DeBrunner, S. Radhakrishnan, Khan Kamal, "The telecomputing laboratory: A multipurpose laboratory," *IEEE Transactions on Education*, v 44, n 4, November 2001, pp. 302-310.
- [5] M. Munoz and S. Garrod, "In process development of an advanced undergraduate communications laboratory," *Proceedings of the 1997 Frontiers in Education Conference*, v2, 1997. Part 2 (of 3), Nov 5-8 1997.
- [6] A. Behagi, "Development of a wireless and satellite communication laboratory at Penn State Harrisburg," *Proceedings of the 1997 ASEE Annual Conference*, Jun 15-18 1997, Milwaukee, WI, USA, 5p.
- [7] E. Bertran, F. Tarres and G. Montoro, "Experimental course on digital communications," *Proceedings of the IEEE International Conference on Electronics, Circuits, and Systems*, v 3, Sep 7-Sep 10 1998, p 321-324.
- [8] W.D. Lane, "Textbook principles to communications hardware: Making it work," *Proceedings of the 1996 Frontiers in Education Conference*, v 3, Nov 6-9 1996, p 1504-1507.
- [9] J.M. Conrad, S. Lasassmeh, I. Vakil and B. Levine, "Teaching Optical Communications Concepts in Embedded Systems Courses," *Proceedings of the 2005 Frontiers in Education Conference*, Indianapolis, IN, October 2005.
- [10] I.Vakil and J.M. Conrad, "Design of a Data Communication Hub for use in Research and Education," *IEEE, SoutheastCon*, Memphis, Tennessee. March 2006
- [11] ATmega128L: http://www.atmel.com/dyn/resources/prod_documents/doc2467.pdf
- [12] HFBR-0400: <http://www.home.agilent.com/semiconductors>
- [13] TFDU4100: <http://www.vishay.com/docs/82514/82514.pdf>
- [14] FT232BM: <http://www.ftdichip.com/Documents/DataSheets/ds232b18.pdf>